

OPERATION
Break-
through



U.S. Department of Housing and Urban Development

DEPARTMENT OF HOUSING
AND URBAN DEVELOPMENT

FEB 20 1975

LIBRARY
WASHINGTON, D.C. 20410

NBSIR 73-165

Fire Endurance Test on a Steel Tubular Column Protected with Gypsum Board

B. C. Son

Center for Building Technology
Institute for Applied Technology
National Bureau of Standards
Washington, D. C. 20234

April 1973

Final Report

Prepared for
Office of Research and Technology
Department of Housing and Urban Development
Washington, D. C. 20410

NBSIR 73-165

**FIRE ENDURANCE TEST ON A STEEL TUBULAR
COLUMN PROTECTED WITH GYPSUM BOARD**

B. C. Son

Center for Building Technology
Institute for Applied Technology
National Bureau of Standards
Washington, D. C. 20234

April 1973

Final Report

Prepared for
Office of Research and Technology
Department of Housing and Urban Development
Washington, D. C. 20410



U. S. DEPARTMENT OF COMMERCE, Frederick B. Dent, Secretary
NATIONAL BUREAU OF STANDARDS, Richard W. Roberts, Director

Fire Endurance Test

on

A Steel Tubular Column Protected with Gypsum Board

by

B. C. Son

Building Fires and Safety Section
Center for Building Technology

ABSTRACT

As a part of the evaluation of housing systems for Operation BREAKTHROUGH a standard fire endurance test was performed at the National Bureau of Standards on a load-bearing steel column construction for use in single-family attached and multifamily low-rise housing. The test method was generally in accord with the requirements of ASTM E 119, Standard Methods of Fire Tests of Building Construction and Materials, for a loaded column. The applied load was 7110 pounds per column and the test results are valid only for columns of such construction loaded at or below the stress level developed by this loading.

The 3 in. x 2 in. x 3/16 in. rectangular hollow tubular steel column was protected with two layers of gypsum board.

The fire endurance of the column assembly was established at 59 minutes, when structural failure occurred.

Key Words: Fire endurance; fire test; housing system; multifamily housing; Operation BREAKTHROUGH; single family attached housing; steel tube column

TABLE OF CONTENTS

	<u>Page</u>
ABSTRACT	i
1.0 INTRODUCTION.	1
2.0 CONSTRUCTION.	1
2.1 Specified Fastener Schedule.	2
2.2 Actual Fastener Schedule	2
3.0 INSTRUMENTATION	2
4.0 DESCRIPTION OF TEST	3
5.0 4.1 Loading.	3
4.2 Furnace Temperature.	4
4.3 Test Evaluation.	4
1. Loaded Column.	4
2. Unloaded Column.	4
5.0 TEST RESULTS.	4
6.0 DISCUSSION.	5
TABLE I.	7
Observation During the Test	
APPENDIX I	8
Load Calculation	
APPENDIX II.	10
SI Conversion Units	

FIGURES

1.0 INTRODUCTION

A standard fire test was conducted to measure the fire endurance of a rectangular hollow tubular steel column having a protective covering of two layers of gypsum board. The test was performed at the Fire Test Laboratories of the National Bureau of Standards, Washington, D.C.

The column for use in single-family attached and multifamily low-rise housing was subjected to the design load of 7110 lbs throughout the test. The fire test followed the requirements for columns of Standard Methods of Fire Tests of Building Construction and Materials, ASTM E 119^{1/}.

2.0 CONSTRUCTION

Figure 1 shows the column assembly in place prior to the fire test. The column assembly was made up of a 3 in. x 2 in. x 3/16 in. hot rolled rectangular structural (ASTM Grade A-36) steel tube protected by two layers of gypsum board. The underlayer was 3/8 in. regular gypsum board and the face (fire-exposed) layer 1/2 in. type C. The fire-exposed face was plastered with 1/8 in. thick joint compound. At the top and the bottom of the column assembly a 6 in. x 9 in. x 3/16 in. thick bearing plate was attached with a continuous fillet weld around all sides of the column leaving an overall column length of 10 ft. 8 in. (including the 3/16 in. bearing plates). Each bearing plate had four 1/2 in. diameter bolt holes located in the corners of the plate 1 in. from each edge. The measured weight of the column assembly was 120 lbs. For the specimen tested the

^{1/}Standard Methods of Fire Tests of Building Construction and Materials, American Society for Testing and Materials Designation E 119-71, available at 1916 Race St., Philadelphia, Pa. 19103.

metal fastener schedule for the gypsum boards varied from the specified fastener schedule shown on design drawing provided by Housing System Producer (HSP).

2.1 Specified Fastener Schedule

The under layer of 3/8 in. regular gypsum board was to be attached with 1 in. long type S-12 bugle head screws along the center of each side at 16 in. centers. The face layer of 1/2 in. type C gypsum board was to be attached with two 1-5/8 in. long S-12 bugle head screws at each corner and at 16 in. centers vertically. The four corners were secured with corner reinforcement (ECONO standard dur-a-bead) which was to be attached with 5/16 in. drywall nails at 24 in. centers. The construction detail of the specimen with specified fastener schedule is shown in Figure 2.

2.2 Actual Fastener Schedule

The fasteners used in the test consisted of 1 in. self drilling bugle head metal screws on the underlayer of gypsum board and 2-1/4 in. self-drilling Phillips recessed flat head metal screws. Both were spaced approximately at 16 in. centers along the center line of each side on the face layer. The corner reinforcement was crimped for holding into the gypsum boards. The photograph in Figure 3 shows the fastening on the actual column and corner reinforcement.

3.0 INSTRUMENTATION

The instrumentation consisted of thermocouples, loading jack and deflection indicator. A total of 15 Chromel-Alumel (type K) thermocouples

was installed on the steel column face at four levels as indicated by the position B, N, M, and T in Figure 4. Three thermocouples were located at level T and four thermocouples at levels B, N, and M. The thermocouples were attached with sheet metal screws to the column prior to attaching the two layers of gypsum boards. The thermocouple wire was wound twice around each screw with the beaded junction under the head of screw. The lead wires were run underneath the bottom layer of gypsum board, up to the underside of the top bearing plate. Care was taken to avoid damaging the thermocouple wires with the screws used for attaching the gypsum boards.

The temperatures of the thermocouples were printed out at 1 minute intervals on a data logger from which they were punched onto cards for processing and plotting by computer.

The vertical deflection of the column assembly during the test was measured by a dial indicator gage, which was placed under the bottom of the loading frame. Figure 4 shows the furnace and loading equipment with the column specimen in place.

4.0 DESCRIPTION OF TEST

4.1 Loading

Because of the furnace construction, the test specimen was fabricated longer than the design column length. The required load was reduced to 7,110 lbs in accordance with the column formula in the AISC^{2/} Manual of Steel Construction. The loading calculation is shown in Appendix I. The load was applied through a hydraulic jack at the bottom of the specimen.

^{2/} Manual of Steel Construction, 7th edition, American Institute of Steel Construction, 101 Park Avenue, New York, New York 10017.

4.2 Furnace Temperature

The temperature inside the furnace was measured by 12 standard Chromel-Alumel thermocouples enclosed in 1/2 in. wrought iron pipes with closed ends placed at various heights around the column. The furnace temperature was constrained to follow the standard ASTM E 119 time-temperature curve by manual control of gas flow to the burners. The actual furnace time-temperature curve is shown in Figure 5.

4.3 Test Evaluation

The fire endurance of a column assembly according to the criteria of ASTM E 119 is as follows:

1. For Loaded Column

The test is regarded as successful if the column sustains the applied load during the fire endurance test for a period equal to that for which classification is desired.

2. For Unloaded Column

The test is regarded as successful if the transmission of heat through the protection during the period of fire exposure for which classification is desired does not raise the average (arithmetical) temperature of the steel at any one of the four levels above 1000°F (538°C) or does not raise the temperature above 1200°F (649°C) at any of the measured points.

5.0 TEST RESULTS

The log of test observations is given in Table I.

The average and the maximum temperature rise of the column thermocouples during the test are shown in Figure 6. At one hour, the column

temperatures ranged approximately from 450°C to 850°C, with an average of 610°C, and a maximum single-point of 830°C. The vertical deflection was measured at the bottom of the loading rig and is shown in Figure 7. Structural failure of the column occurred at 61 min:50 sec. when the column could not sustain the applied load, as shown in Figure 7. The corrected time of the structural failure, according to the standard correction formula in ASTM E 119 which is based on the comparison of the areas under the actual time-temperature curve and the standard curve, was 59 minutes. In spite of the applied load, the length of the column expanded due to the furnace heat. Just prior to the failure, the length of the column had expanded approximately 0.8 inches.

Figure 8 shows the conditions of the column at the end of the test and the bowing of the column near the bottom.

6.0 DISCUSSION

Since the test was performed under the design load, the E 119 criterion for fire endurance was only based on sustaining the applied load. Therefore, the temperature readings of the steel are provided for information only for evaluating the column protection during the test. As shown in Figure 6, the time to an average temperature rise of 538°C and a maximum temperature rise of 649°C were 57.5 minutes and 53.5 minutes, respectively.

As mentioned in "2.0 Construction", the fastener schedule on the column assembly tested was different from that shown on design drawings provided by the HSP. In fire endurance tests, the fastener schedule can sometimes have a large effect on the fire performance of an assembly.

A load of 7110 lbs was applied to the column. The test result should be applied only to columns of such construction loaded to develop stresses not exceeding those developed in this test.

TABLE I
OBSERVATIONS DURING THE TEST

<u>Time</u> Min:Sec	<u>Observations</u>
0:00	Start test.
1:00	Paper burning on the exposed gypsum board.
2:00	Completion of paper burning.
4:00	Green flame from paint burning on the corner reinforcement.
5:00	The corner angle reinforcement beginning to separate.
7:30	Gypsum boards on the exposed surface starting to buckle horizontally and vertically.
10:00	Near the mid-height of the column small pieces of gypsum board on the north and east side are beginning to fall in.
12:00	The corner angle reinforcement has been separated and is hanging down. (Figure 9).
28:00	The corner joints on the south and east side of the gypsum boards have opened up about 3/8 inch. The south gypsum boards are buckling a little and this is slowly increasing.
45:00	The gypsum board on the south face has separated about one foot. Horizontal cracks are observed on the under layer of gypsum board on south side. On the north side the separation of the face gypsum board has increased to about 6 inches. (Figure 10)
48:00	On the north face there was a crack about three feet from the bottom of the specimen. A piece of gypsum board from the face layer about 1 foot high has fallen down.
55:00	On the east side the face gypsum board has come off and the under layer is now exposed.
56:00	The underlayers of gypsum board have started to come off and the steel face is exposed at the bottom of the column.
59:00	The column is starting to buckle.
61:50 (59:00)*	Load failure.

* Corrected time according to the standard correction formula is ASTM E 119.

APPENDIX I

Load Calculation For Increased Column Length

Prototype Column

Structural Rectangular Steel Tube 3 in. x 2 in. x 3/16 in.

Area: $A = 1.644 \text{ in.}^2$

Radius of Gyration: $r = 0.77 \text{ in.}$

Design Load: $P_a = 14.3 \text{ KIPS}$

Length: $L_d = 7 \text{ ft. } 6 \text{ in.} = 90 \text{ in.}$

$$L_d/r = 90/0.77 = 117$$

Axial stress permitted in the absence of bending moment

$F_d = 10.91 \text{ KSI}$ From Table 1-36 in AISC (Manual of
Steel Construction, 7th Edition)

The allowable load to produce the working stress

$$P_{ad} = A \times F_d = 1.644 \times 10.91 = 17.95 \text{ KIPS}$$

The percentage of design load to allowable load

$$\frac{14.3}{17.95} \times 100 = 79.7\%$$

Fire Test Column

Same rectangular tube with length

$L_f = 10 \text{ ft. } 8 \text{ in.} = 128 \text{ in.}$

$$L_f/r = \frac{128}{0.77} = 166.23$$

Axial stress permitted in the absence of bending moment

$F_f = 5.42 \text{ KSI}$ From Table 1-36 in AISC (Manual of
Steel Construction, 7th Edition)

The allowable load to produce the working stress

$$P_f = A \times F_f = 1.644 \times 5.42 = 8.91 \text{ KIPS}$$

The load applied to the test column

$$P_{af} = 8.91 \times \frac{79.7}{100} = 7.11 \text{ KIPS}$$

APPENDIX II

SI Conversion Units

In view of present accepted practice in this country in this technological area, common US units of measurement have been used throughout this paper. In recognition of the position of the United States as a signatory to the General Conference of Weights and Measurements which gave official status to the metric SI system of units in 1960, we assist readers interested in making use of the coherent system of SI units by giving conversion factors applicable to US units used in this paper.

Length

$$1 \text{ in} = 0.0254 \text{ meter}$$

$$1 \text{ ft} = 0.3048 \text{ meter}$$

Mass

$$1 \text{ lb} = 0.45359237 \text{ kilogram}$$

Force

$$1 \text{ kip} = 4448 \text{ newton}$$

Stress

$$1 \text{ psf} = 47.88 \text{ newton/meter}^2$$

Temperature

$$\text{Temperature in } ^\circ\text{F} = 9/5 (\text{temperature in } ^\circ\text{C}) + 32^\circ\text{F}$$



Figure 1. The column assembly in place
prior to fire test.

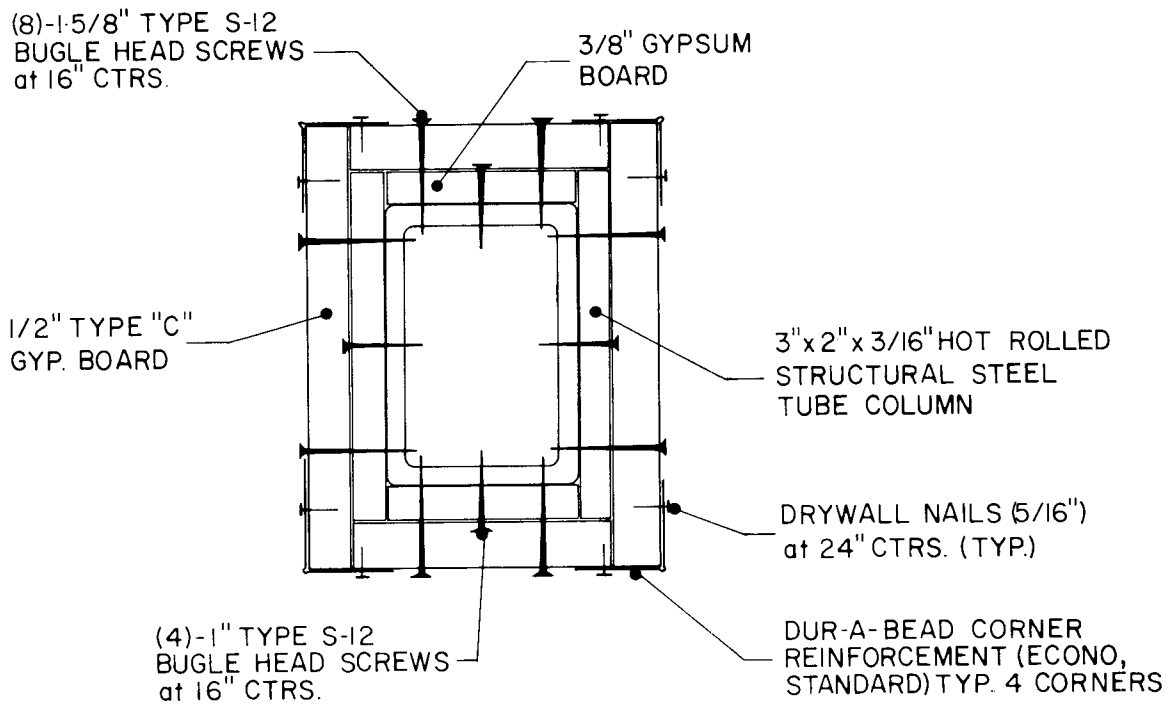

Figure 2. Section detail of the column with specified fastening (not tested).



Figure 3 Steel tube and its section with nailing, corner reinforcement, and two types of screws used.

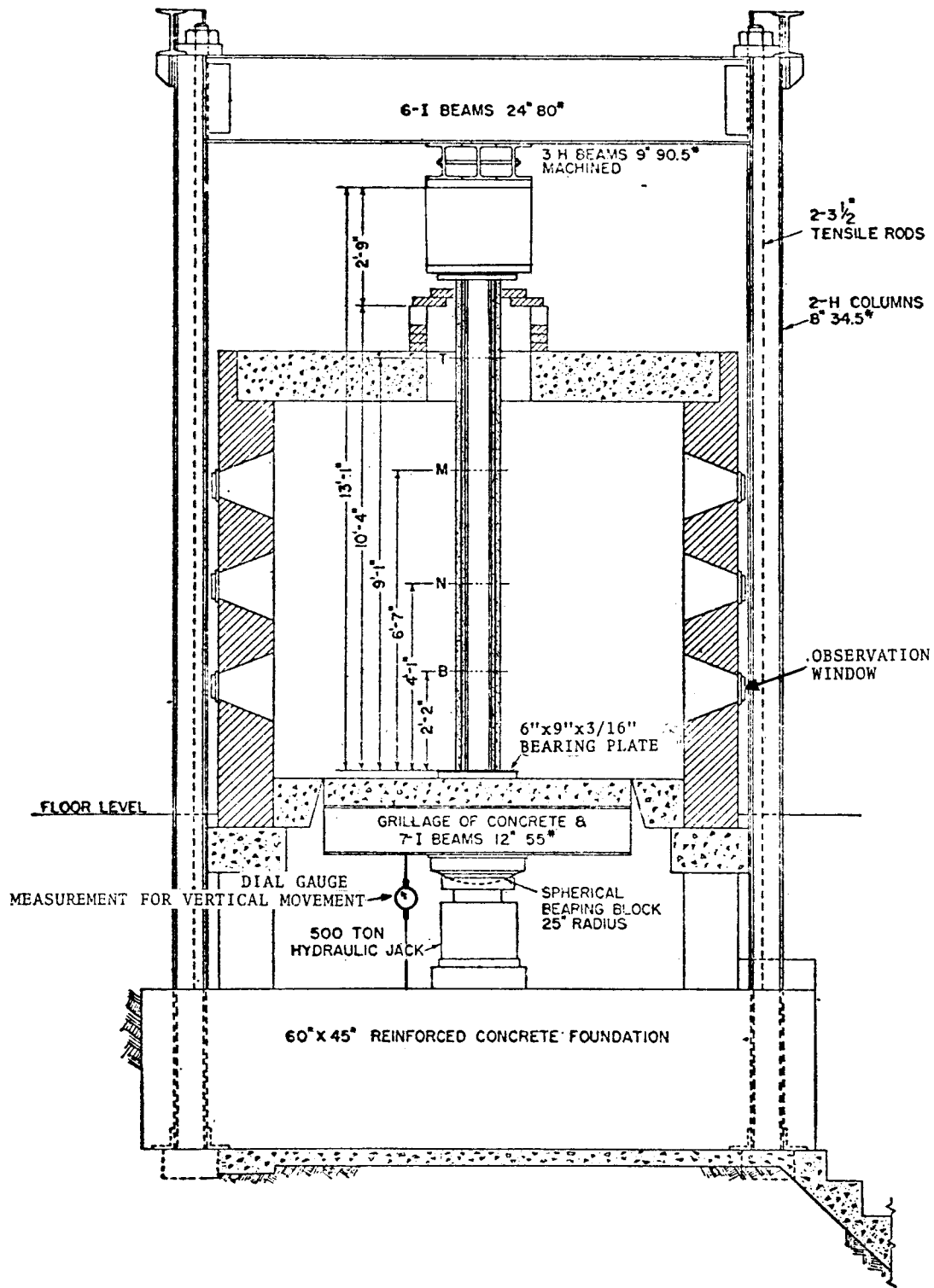

Figure 4. Furnace and loading equipment with typical column in place.

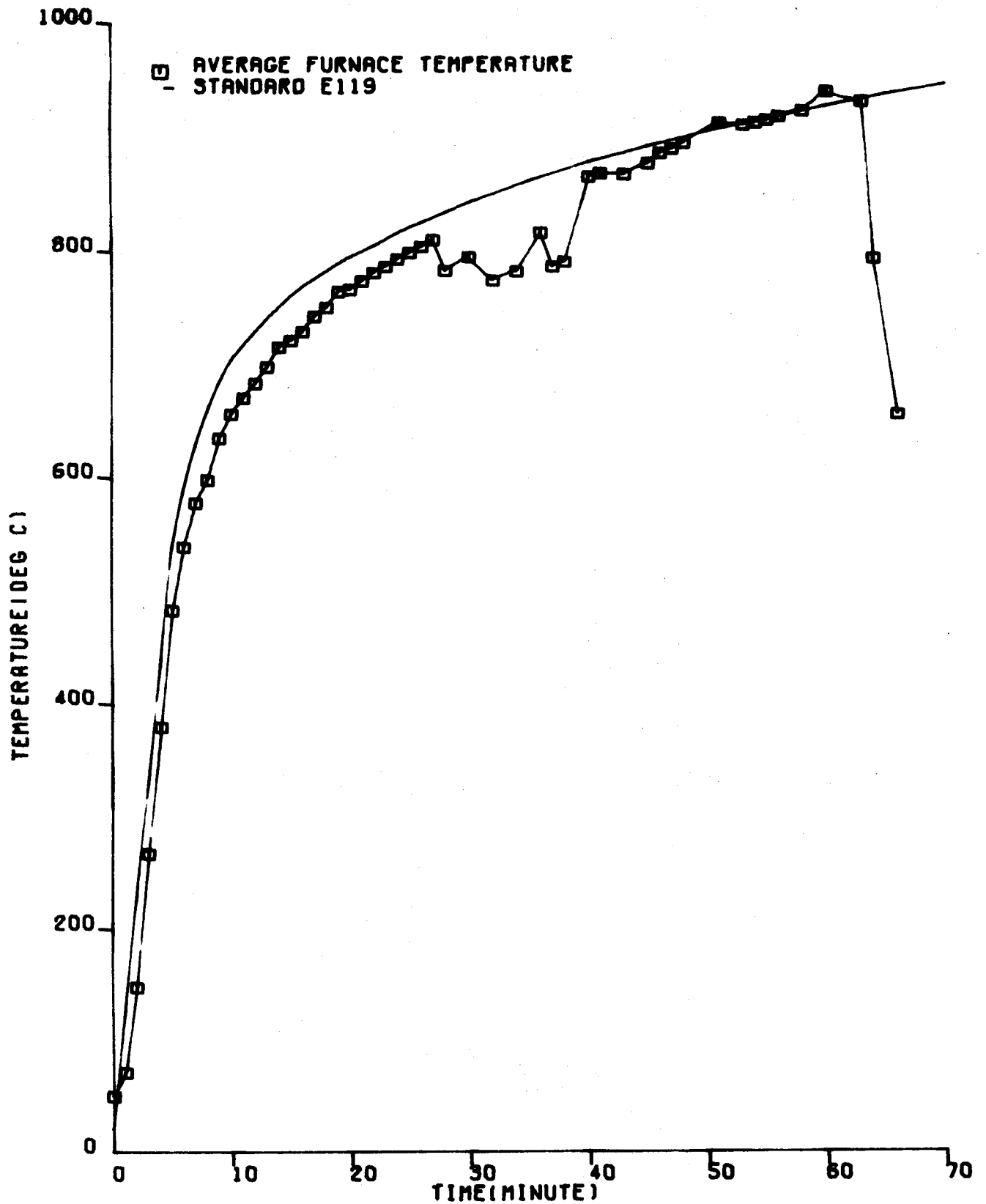

Figure 5
 Average Furnace Temperature Compared With Standard ASTM E 119 Curve (Test-495)

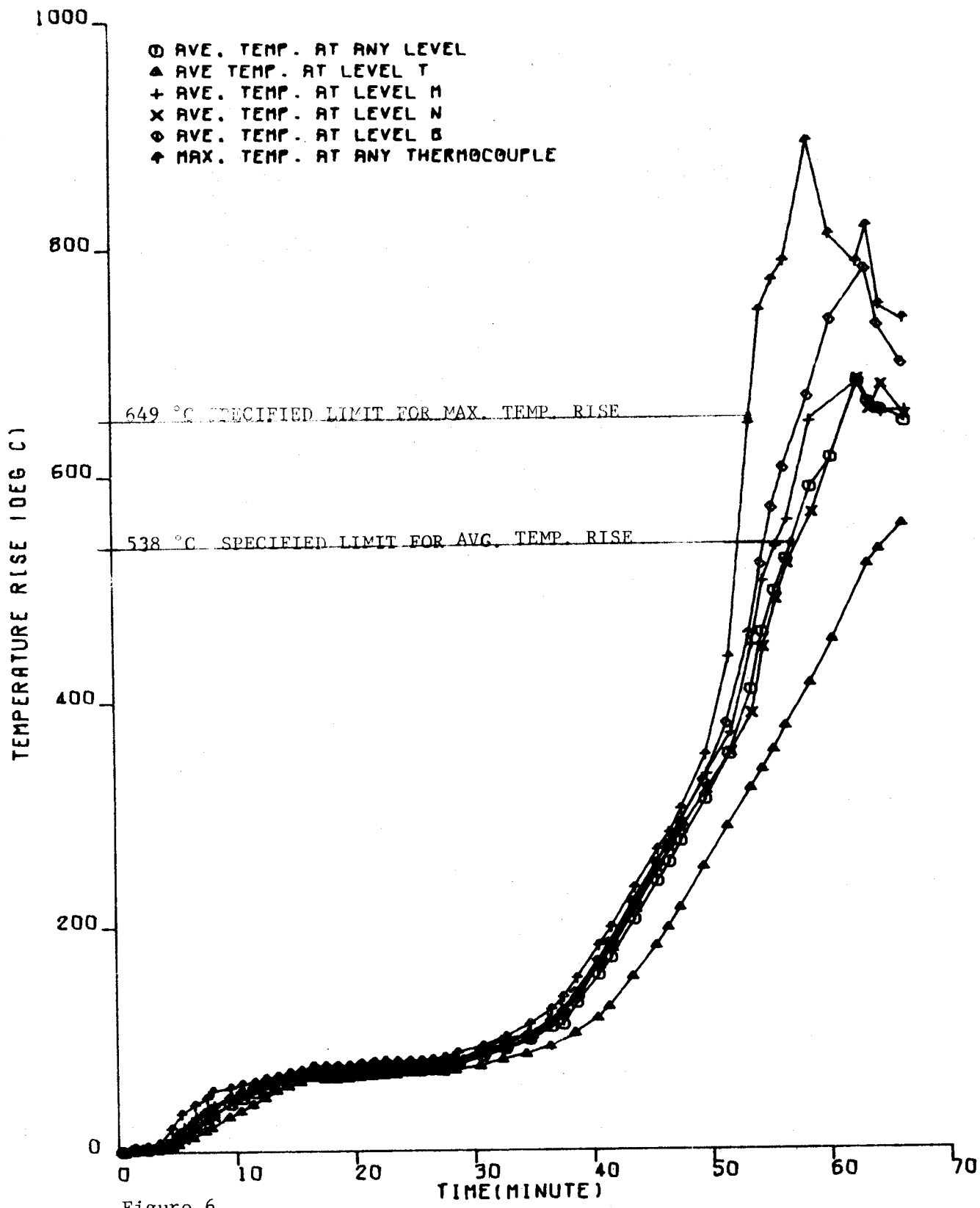

Figure 6
 Average Temperature Rise On The Steel Surface At Any Level. At Level T. M. N.
 And B And Maximum Temperature Rise At Any Thermocouple (Test-495)

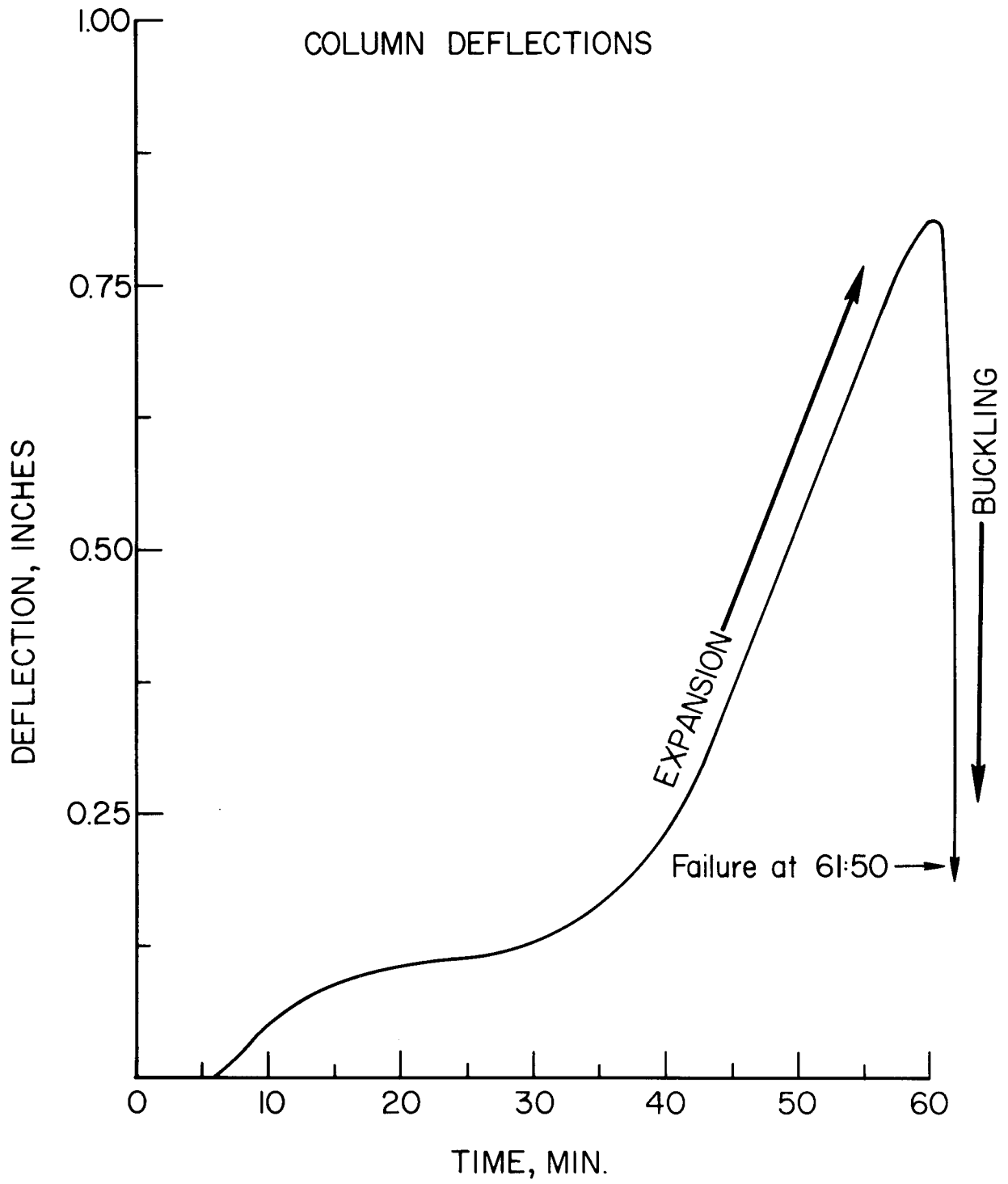

Figure 7. Vertical deflection of the column during the test.



Figure 8. The condition of the column at the end of the test.



Figure 9. Note the corner reinforcement separating from the column.
Test time of 12 minutes.

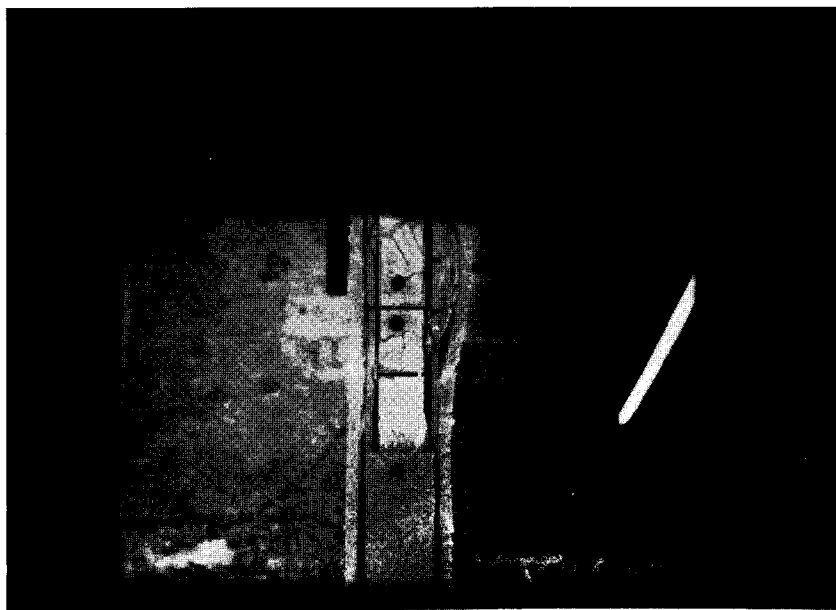

Figure 10. Gypsum covers on the column are falling down.
Test time of 45 minutes.

U.S. DEPT. OF COMM. BIBLIOGRAPHIC DATA SHEET	1. PUBLICATION OR REPORT NO. NBSIR 73-165	2. Gov't Accession No.	3. Recipient's Accession No.
4. TITLE AND SUBTITLE Fire Endurance Test on a Steel Tubular Column Protected With Gypsum Board		5. Publication Date	
		6. Performing Organization Code	
7. AUTHOR(S) Byung Chan Son		8. Performing Organization NBSIR 73-165	
9. PERFORMING ORGANIZATION NAME AND ADDRESS NATIONAL BUREAU OF STANDARDS DEPARTMENT OF COMMERCE WASHINGTON, D.C. 20234		10. Project/Task/Work Unit No. 4600437	
		11. Contract/Grant No. IAA-H-16-70	
12. Sponsoring Organization Name and Address Department of Housing and Urban Development Washington, D.C. 20410		13. Type of Report & Period Covered Final	
		14. Sponsoring Agency Code	
15. SUPPLEMENTARY NOTES			
<p>16. ABSTRACT (A 200-word or less factual summary of most significant information. If document includes a significant bibliography or literature survey, mention it here.)</p> <p>As a part of the evaluation of housing systems for Operation BREAKTHROUGH a standard fire endurance test was performed at the National Bureau of Standards on a load-bearing steel column construction for use in single-family attached and multifamily low-rise housing. The test method was generally in accord with the requirements of ASTM E 119, Standard Methods of Fire Tests of Building Construction and Materials, for a loaded column. The applied load was 7110 pounds per column and the test results are valid only for columns of such construction loaded at or below the stress level developed by this loading.</p> <p>The 3 in. x 2 in. x 3/16 in. rectangular hollow tubular steel column was protected with two layers of gypsum board.</p> <p>The fire endurance of the column assembly was established at 59 minutes, when structural failure occurred.</p>			
17. KEY WORDS (Alphabetical order, separated by semicolons) Fire endurance; fire test; housing system; multifamily housing; Operation BREAKTHROUGH; single family attached housing; steel tube column			
18. AVAILABILITY STATEMENT <input checked="" type="checkbox"/> UNLIMITED. <input type="checkbox"/> FOR OFFICIAL DISTRIBUTION. DO NOT RELEASE TO NTIS.		19. SECURITY CLASS (THIS REPORT) UNCLASSIFIED	21. NO. OF PAGES
		20. SECURITY CLASS (THIS PAGE) UNCLASSIFIED	22. Price