

# ***Concrete Masonry Homes: Recommended Practices***

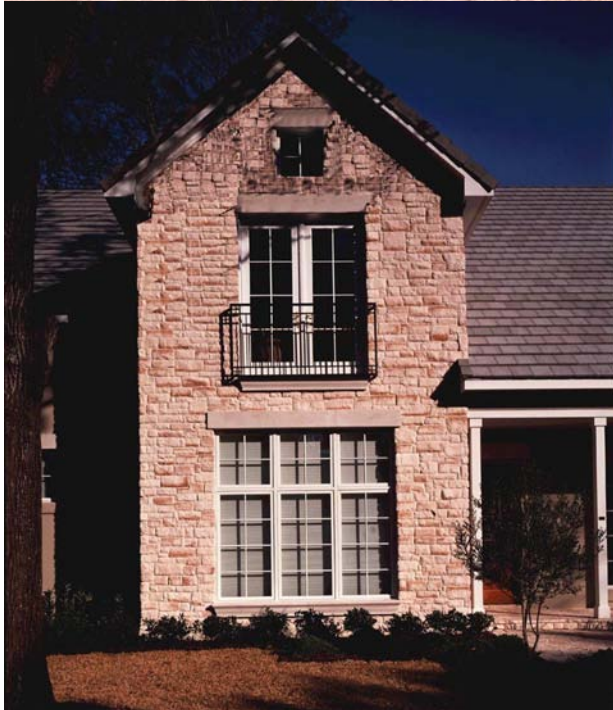



# ***Concrete Masonry Homes: Recommended Practices***

Prepared for

National Association of Home Builders  
Washington, DC

National Concrete Masonry Association  
Herndon, VA

Portland Cement Association  
Skokie, IL

and

U.S. Department of Housing and Urban Development  
Office of Policy Development and Research  
Washington, DC

Prepared by  
NAHB Research Center, Inc.  
Upper Marlboro, MD

Contract H-21134CA

September 1999

# Acknowledgments

This report was prepared by the NAHB Research Center, Inc., under the sponsorship of the U.S. Department of Housing and Urban Development (HUD). We wish to recognize the National Concrete Masonry Association (NCMA), the Portland Cement Association (PCA), and the National Association of Home Builders (NAHB) whose cofunding and participation made the project possible. Special appreciation is extended to William Freeborne of HUD, Fernando Sabio of NCMA, and Donn Thompson of PCA for their guidance throughout the project.

The principal authors of this report are Andrea Vrankar, P.E., R.A., and David Edwards. Figures were produced by Mallika Kishen and Barbara Vrankar Karim. Appreciation is especially extended to the following individuals who provided guidance on this document and whose input made this work complete:

Larry Chappell, W.R. Grace  
Jay Crandell, P.E., NAHB Research Center, Inc.  
Tague Damberg, Allan Block Corporation  
Attilio DiMarco, PEI Homes, Inc.  
David Edwards, NAHB Research Center, Inc.  
Nader Elhajj, P.E., NAHB Research Center, Inc.  
Pat Ellison, Jr., Block Joist® Company, LLC  
William Freeborne, U.S. Department of  
Housing and Urban Development  
Jerry Hoopingarner, NAHB Research Center,  
Inc.  
Ed Hudson, NAHB Research Center, Inc.  
Dennis Graber, National Concrete Masonry  
Association  
Jeff Greenwald, National Concrete Masonry  
Association  
Kirk Grundahl, P.E., Wood Truss Council of  
America  
Barbara Vrankar Karim  
John Keho, Hilti, Inc.  
Tom Kenney, P.E., NAHB Research Center,  
Inc.

Mallika Kishen, NAHB Research Center, Inc.  
Gus Lorber, Allied Concrete  
Randy MacGillivray, MacGillivray Masonry  
and General Contractors  
Scott Miller, Owens Corning  
Paul Mysinger, Mysinger Builders  
Raymond Nelson, Earthwise Architecture  
Mark Nowak, NAHB Research Center, Inc.  
Alan Aronie, Quickpoint™, Inc.  
Fernando Sabio, CCCM, CDT, CSI, National  
Concrete Masonry Association  
Dean Seibert, Avalon Concepts  
Michelle Shiira, Simpson Strong-Tie  
Mark Surette, Chaney Enterprises  
Donn Thompson, AIA, Portland Cement  
Association  
Jason Thompson, National Concrete Masonry  
Association  
Andrea Vrankar, P.E., R.A., NAHB Research  
Center, Inc.  
Joseph Weihagen, NAHB Research Center, Inc.

## DISCLAIMER

Although the information in this guidebook is believed to represent current practice accurately, the U.S. Department of Housing and Urban Development, the Portland Cement Association, the National Concrete Masonry Association, nor the NAHB Research Center, Inc., or any of their employees or representatives make any warranty, guarantee, or representation, expressed or implied, with respect to the accuracy, effectiveness, or usefulness of any information, method, or material in this guidebook, or assumes any liability for the use of any information, methods, or materials disclosed herein, or for damages arising from such use.

## NOTICE

The contents of this report are the view of the contractor and do not necessarily reflect the views or policies of the U.S. Department of Housing and Urban Development or the U.S. government. The U.S. government does not endorse products or manufacturers. Trade or manufacturer names appear herein solely because they are considered essential to the object of this report.

# Foreword

The U.S. Department of Housing and Urban Development (HUD) in the past several years has focused on a variety of innovative building materials and systems for use in residential construction. HUD's interest in alternative materials has focused on addressing barriers to innovations and educating home builders, home buyers, code officials, and design professionals in key aspects of a particular material's use, including limitations, advantages, availability, and cost in an effort to accelerate development, acceptance, and implementation by the home building industry. Innovative design and construction approaches using wood, steel, and concrete materials have thus far been addressed as viable alternatives to conventional residential construction methods and materials.

Concrete masonry units (CMUs) have also been identified because of the material's availability, strength, durability, fire resistance, and success in the commercial and localized residential markets. CMUs are hollow blocks constructed of concrete that are stacked, typically in a running bond pattern, and held together with mortar. CMUs comprise a significant percentage of the United States residential foundation wall market and have a long history of residential use above grade in Arizona, Florida, Texas, and other parts of the southern United States.

Even though CMUs are used in residential construction, builders and designers are often hesitant to explore approaches that differ from conventional practice. In many instances, such reluctance can be attributed to a lack of information, lack of sharing across regional barriers, or localized customs in building materials and methods. Therefore, CMU demonstration homes were constructed in nontraditional masonry market regions of the United States to identify the major issues related to the design and construction of CMU homes. The results are presented in *Building Concrete Masonry Homes: Design and Construction*. The major issues identified in that report serve as the basis for this document and its recommended construction practices.

This report, *Concrete Masonry Homes: Recommended Practices*, focuses on the attachment or installation of foundations, floors, roofs, insulation, utilities, and finishes to concrete masonry walls as well as on special tools and fasteners available for use with concrete masonry. An effort has been made to provide construction details that highlight the use of masonry in conjunction with various innovative materials such as cold-formed steel framing and engineered wood products.

We believe that providing this information to the home building industry will promote healthy competition and help define optimal use of all of our natural resources while enhancing housing affordability.

Xavier de Souza Briggs  
Deputy Assistant Secretary for  
Research, Evaluation, and Monitoring  
U.S. Department of Housing and Urban Development



# Table of Contents

Acknowledgments	
Foreword	
Executive Summary .....	ix
FS•1, Foundation Connections .....	1
FS•2, Floor Connections .....	7
FS•3, Roof Connections .....	13
FS•4, Finish Attachments.....	19
FS•5, Insulation Placement .....	29
FS•6, Utility Placement .....	35
FS•7, Tools and Fasteners .....	39

# List of Figures

Figure 1-1a	Foundation Stem Wall and Slab on Grade.....	1
Figure 1-1b	Foundation Stem Wall and Slab on Grade.....	2
Figure 1-2	Monolithic Slab on Grade (Thickened-Edge Slab).....	2
Figure 1-3	Interior Bearing-Wall Foundation .....	2
Figure 1-4	Basement Wall .....	3
Figure 1-5	Crawl Space Wall .....	3
Figure 1-6	Moisture and Water Control Measures .....	4
Figure 2-1	Wood Floor Pocket Connection.....	8
Figure 2-2	Wood Floor Direct-Bearing Connection.....	8
Figure 2-3	Wood Floor Ledger Connection .....	9
Figure 2-4	Wood Truss Floor Direct-Bearing Connection.....	9
Figure 2-5	Wood Truss Floor Pocket Connection .....	9
Figure 2-6	Cold-Formed Steel Floor Direct-Bearing Connection .....	10
Figure 2-7	Cold-Formed Steel Floor Ledger Connection .....	10
Figure 2-8	Steel Joist Floor Direct-Bearing Connection .....	10
Figure 2-9	Steel Joist Floor Ledger Connection .....	10
Figure 2-10	Block Joist <sup>®</sup> Floor System .....	11
Figure 2-11	Precast Concrete Floor Direct-Bearing Connection .....	11
Figure 3-1	Wood Roof Truss (or Rafter) Direct-Bearing Connection.....	14
Figure 3-2	Cold-Formed Steel Roof Direct-Bearing Connection.....	14
Figure 3-3	Steel Bar Joist Roof Direct-Bearing Connection.....	15
Figure 3-4	Steel Bar Joist Roof Ledger Connection.....	15
Figure 3-5	Block Joist <sup>®</sup> Roof System .....	15
Figure 3-6	Precast Concrete Roof System.....	16
Figure 4-1	Hollow Concrete Masonry Units .....	19
Figure 4-2	Brick Veneer (Cavity Wall) .....	20
Figure 4-3	Brick Veneer (Composite Wall) .....	20
Figure 4-4a	Novabrik <sup>™</sup> by the Allan Block Corporation.....	20
Figure 4-4b	Novabrik <sup>™</sup> by the Allan Block Corporation.....	21
Figure 4-5	Patented Thin Brick Veneer .....	21
Figure 4-6	Stone Veneer.....	22
Figure 4-7	Cultured Stone Veneer .....	22
Figure 4-8	Wood, Aluminum, Vinyl, or Fiber-Cement Siding.....	23
Figure 4-9	Stucco .....	24
Figure 4-10	EIFS (Drainable).....	24
Figure 4-11	EIFS (Nondrainable).....	25
Figure 4-12	Gypsum Board .....	25
Figure 4-13	In•Sulate by Agile Building Systems, LLC.....	25
Figure 4-14	Plaster in a Roll <sup>™</sup> by Flexi-Wall Systems .....	25
Figure 5-1	Molded Insert Core Insulation .....	30
Figure 5-2	Exterior Surface Insulation .....	31
Figure 5-3	Interior Surface Insulation.....	32
Figure 5-4	Multiwythe Wall Insulation .....	33
Figure 5-5	Patented Composite Wall Insulation .....	33
Figure 6-1	Utility Penetration through CMU Wall.....	36



## List of Figures (cont'd.)

Figure 6-2	Electrical Raceway by Wiremold Company .....	36
Figure 6-3	Shallow Electrical Box Installation.....	36
Figure 6-4	Standard Electrical Box Installation.....	36
Figure 6-5	Electrical Installation in Insulated CMU Wall .....	37
Figure 6-6	Plumbing Rough-In on Exterior CMU Wall.....	37

## List of Tables

Table 5-1	Typical R-Values.....	29
Table 7-1	Fastening Methods by Application .....	39
Table 7-2	Common Fasteners.....	41
Table 7-3	Common Tools .....	47



# Executive Summary

*Concrete Masonry Homes: Recommended Practices* was developed as a guideline for using concrete masonry in the construction of homes in the United States. This document was prepared in response to previous research efforts funded by the U.S. Department of Housing and Urban Development (HUD), the National Concrete Masonry Association (NCMA), and the Portland Cement Association (PCA). The previous years' research efforts focused on constructing two demonstration homes to help identify key issues builders face when constructing homes with concrete masonry, especially homes with above-grade walls in nontraditional masonry markets. The results of that study are documented in *Building Concrete Masonry Homes: Design and Construction*. The connection of various materials and products to concrete masonry walls was one key issue identified by the study, particularly in regions unfamiliar with concrete masonry construction.

This document focuses primarily on the attachment of common residential materials and elements to concrete masonry wall construction. The installation of certain materials or products commonly affects the installation of other materials or elements; in addition, tools and fasteners used for one type of application may be used for another. Needless to say, materials and elements may be installed in many possible combinations. In an effort both to present an abundance of information in a concise manner and limit the amount of cross-referencing between fact sheets, this document is divided into seven fact sheets as listed below. Each fact sheet focuses on a specific type of connection or attachment. The first three fact sheets primarily address structural connections, the fourth focuses on common finishes that may be used on CMU walls, the fifth deals with thermal aspects of CMU construction, the sixth concentrates on utility placement alternatives, and the seventh considers common tools and fasteners used to install the items discussed in the previous fact sheets.

FS•1, Foundation Connections  
FS•2, Floor Connections  
FS•3, Roof Connections  
FS•4, Finish Attachments

FS•5, Insulation Placement  
FS•6, Utility Placement  
FS•7, Tools and Fasteners

To gain a greater understanding of residential concrete masonry construction and the various possible combinations for the installation of materials and elements, the reader is encouraged to read the entire document and determine, well before the design stage, which issues are of primary importance and how the selected priority items affect other elements of construction. For example, insulation is not shown in the illustrations found in Fact Sheets 1 through 4; the reason is that various alternatives concerning insulation placement, if required by local code, are covered in Fact Sheet 5. By combining the information presented in Fact Sheets 1 through 4 with that found in Fact Sheet 5, a CMU wall may be constructed to meet local energy code requirements, as applicable. In addition, by reading the information presented in Fact Sheet 6, the reader can determine how the choice of insulation placement determines the installation of utilities. Finally, by reading Fact Sheet 7, the reader can identify what tools and fasteners are needed during construction based on the required types of attachments.



# Foundation Connections

FS · 1

An information series on residential concrete masonry technology

## SUMMARY

A foundation in residential construction may consist of a footing, wall, slab, pile or pier, or combination of two or more of these elements. Residential foundation systems in the United States are most often constructed of concrete masonry or concrete. Of these foundations, stem walls in conjunction with slabs on grade and monolithic slabs on grade are the most common in the Southeast, basements most common in the East and Midwest, and crawl spaces most common in the Northwest and West. Other types of foundations may be used depending on local tradition or special site conditions.

Given that many residential foundations are constructed with concrete masonry, builders should be familiar with foundation details using concrete masonry. In certain areas of the country, however, home builders and designers are less familiar with CMU construction practices.

The details shown herein are “generic” and “typical” for low-wind and seismic areas (less than 110 mph three-second-gust wind speed and less than Seismic Design Category D). It is suggested that the designer or builder consult local building codes and recognized standards to determine footing size, reinforcement requirements, anchor bolt spacing, and thermal requirements.

For higher-wind and seismic areas, homes should be built in accordance with local codes and recognized standards; refer to the Resources section for more information.

## FOUNDATION TYPES

### Stem Wall and Monolithic Slab on Grade

Slab-on-grade floors are popular in the southeastern United States. A slab-on-grade floor is approximately 4-inch-thick concrete in residential construction and is supported by or rests on approved fill beneath it. Foundations used in conjunction with slabs on grade can be constructed a variety of ways; however, the two most popular ways are:

- ✓ foundation stem wall and slab on grade; and
- ✓ monolithic slab on grade (thickened-edge slab).

Refer to Figures 1-1a and 1-1b for *foundation stem wall and slab on grade* and Figure 1-2 for *monolithic slab on grade*. The figures illustrate the foundation types and some recommended methods for constructing slab-on-grade foundations.

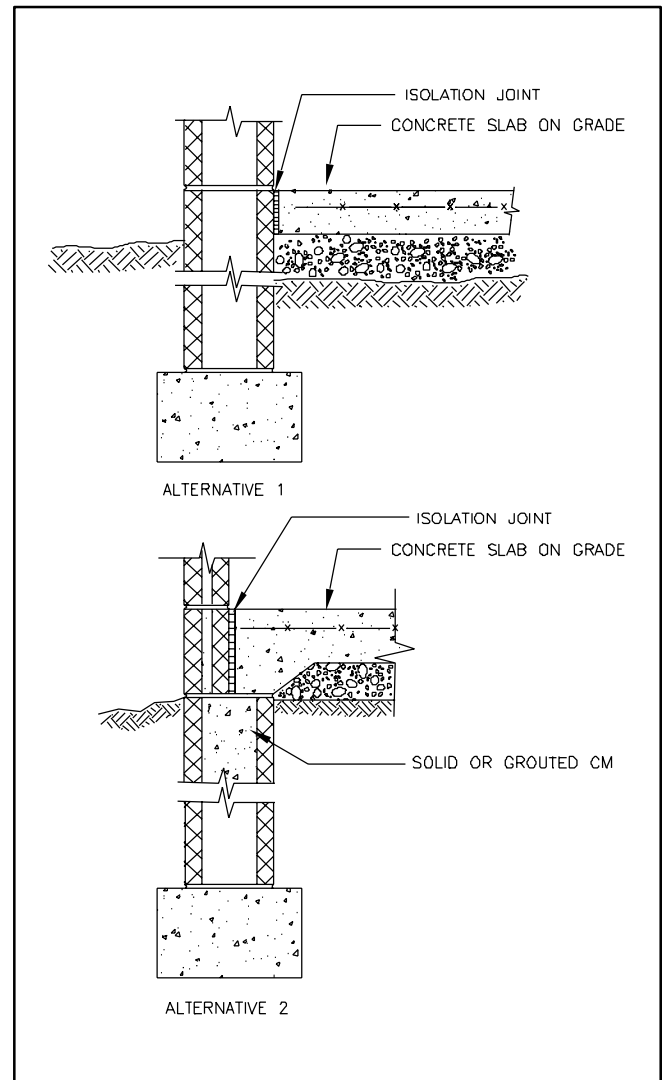

Figure 1-1a: Foundation Stem Wall and Slab on Grade

Foundation stem wall and slab on grade construction uses a concrete floor that is supported by the earth beneath it and isolated from the concrete masonry walls. The stem walls are erected first and the slab poured afterward.

The slab may also be supported by the concrete masonry stem wall at the perimeter and by the fill beneath. The concrete masonry stem wall is constructed to form a continuous ledge on which the slab's edges bear. The detail shown in Figure 1-1a, Alternative 1, is used when differential settlement at the slab edge (between the foundation and slab) may be a problem. Alternatives 2, 3, and 4 may be used if little or no differential settlement between the slab and the foundation is expected. All alternatives are acceptable.

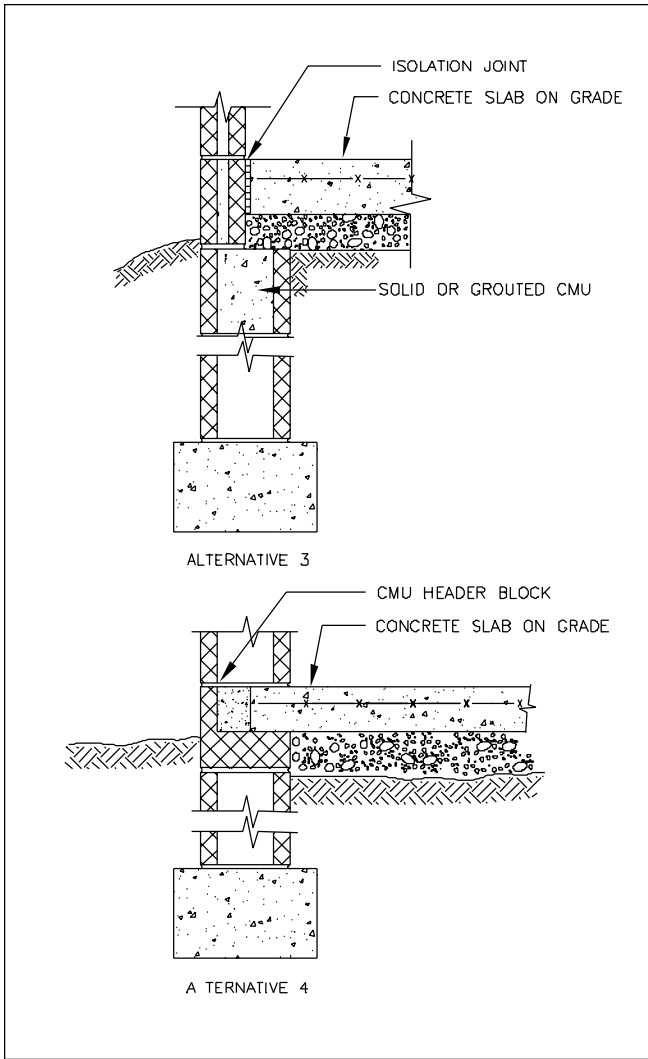

Figure 1-1b: Foundation Stem Wall and Slab on Grade

Designers typically specify an isolation joint between the slab and the wall to allow the slab to shrink or expand independent of the wall. Asphalt-impregnated fiber sheathing is one commonly used isolation joint material. If the slab is not allowed to move independently, cracking may occur perpendicular to the wall. On many residential job sites, however, the slab is cast against the wall, or a more rigid material is used to provide a slippage surface. There is no evidence to suggest that homes constructed with the slab cast against the wall perform less adequately than homes built with isolation joints. Although not currently required in the *International Residential Code*, an isolation joint is suggested in this guide as a *best practice* simply because it may make any cracks less evident and thus reduce customer dissatisfaction. It can also serve as a screed mark for maintaining a level finished slab surface.

A *monolithic slab on grade* is also commonly referred to as a thickened-edge slab. It consists of a concrete floor and concrete foundation placed at the same time to form a monolithic footing and slab. Refer to Figure 1-2 for a typical monolithic slab on grade.

Regardless of the perimeter foundation type, slabs are cast thicker under interior load-bearing walls to help support the loads from above. Thus, the location of the interior masonry walls must be known so that preparations for thickened interior slab footings can be made. Refer to

Figure 1-3 for some recommended methods for supporting interior masonry walls.

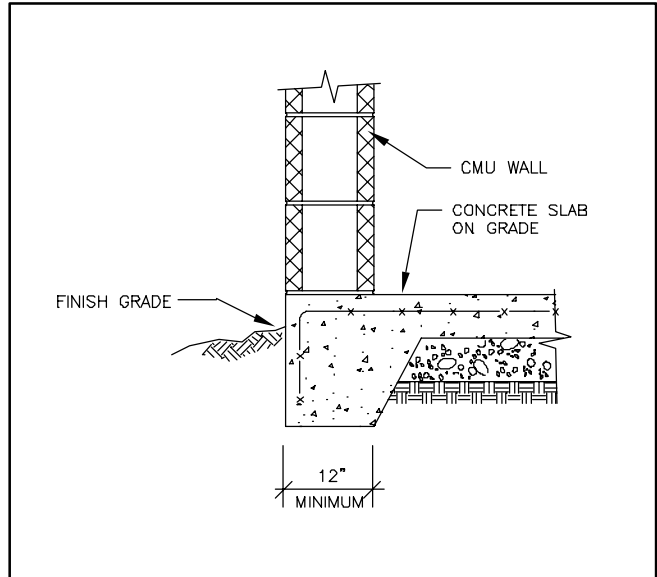

Figure 1-2: Monolithic Slab on Grade (Thickened-Edge Slab)

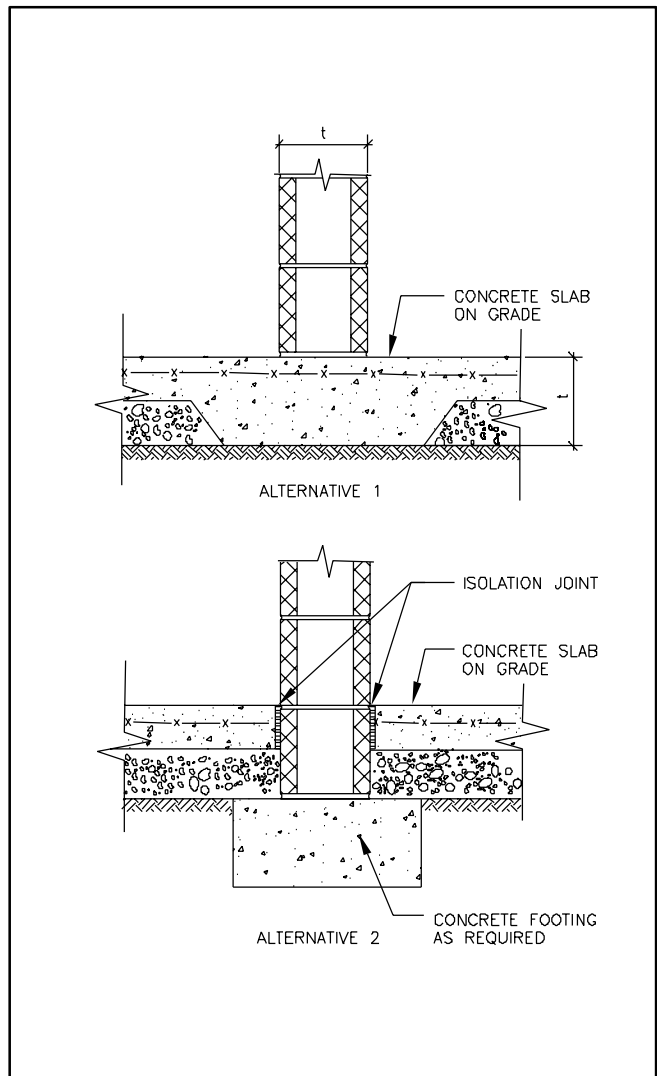

Figure 1-3: Interior Bearing-Wall Foundation

## Basements

Basement foundations are popular in the Northeast and Midwest. A basement is defined as that portion of a building that is partly or completely below grade. It may be used as habitable space. Refer to Figure 1-4, which illustrates the recommended method for constructing basement foundations.

Basements are constructed with an independent concrete slab that is isolated from the concrete masonry walls. The basement floor is typically poured after the concrete masonry walls have been erected or partially erected.

Designers typically specify an isolation joint to allow the slab to shrink or expand independent of the wall. Although considered a *best practice*, isolation joints may not be necessary in residential construction; refer to the *Stem Wall and Monolithic Slab on Grade* section for a discussion on the use of isolation joints.

Note that a reinforcement dowel between the footing and CMU wall is not required in Figure 1-4 for basement wall construction. The reason is that the slab on grade is placed within the wall perimeter and thus provides adequate resistance against inward slipping caused by backfill loads; however, temporary bracing is recommended if the slab is not placed before backfill placement.

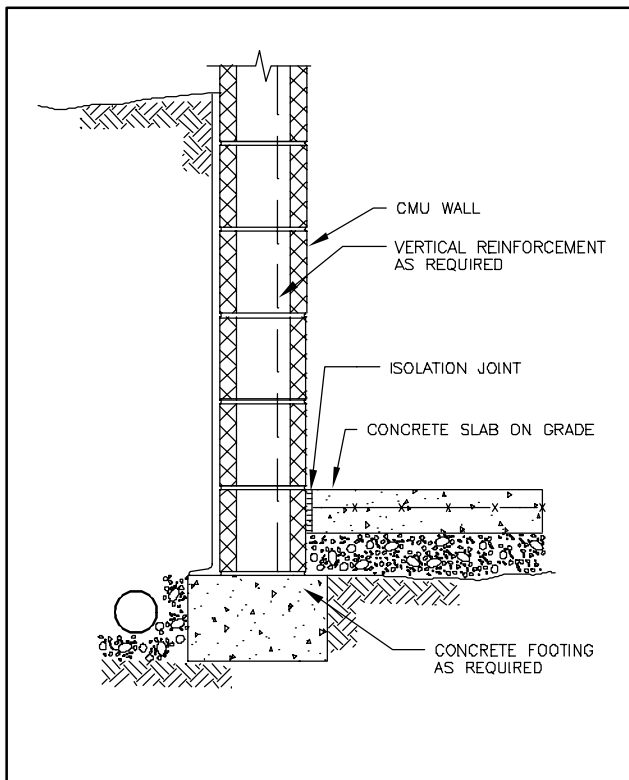

Figure 1-4: Basement Wall

Some designers may specify vertical reinforcement in basement walls depending on the depth of unbalanced soil and the type of soil or lateral soil pressure. Many factors influence a basement wall's performance, particularly backfill soil type, compaction method, foundation drainage, depth of backfill, the vertical load on the wall, and workmanship. Any one of these factors may affect performance of the construction. As a rule of thumb, the

*International Residential Code* and most local codes allow unreinforced basement wall construction if the soil pressure is no greater than 30 psf; however, it limits the depth of unbalanced backfill based on wall thickness. Refer to the *International Residential Code* or the applicable local building code for maximum backfill heights for plain masonry foundation walls.

Horizontal bed joint reinforcement, if installed, is placed in the mortar joint between block courses. Its purpose is to tie the wall together and provide resistance to cracking due to temperature expansion and shrinkage in the wall.

## Crawl Spaces

Crawl space foundations are popular in the Northwest, West, and Mid-Atlantic regions. A crawl space is defined as that portion of a building that uses a perimeter foundation wall to create an under-floor space that is not habitable. A crawl space may or may not be below grade. Refer to Figure 1-5, which illustrates some recommended methods for constructing crawl space foundations.

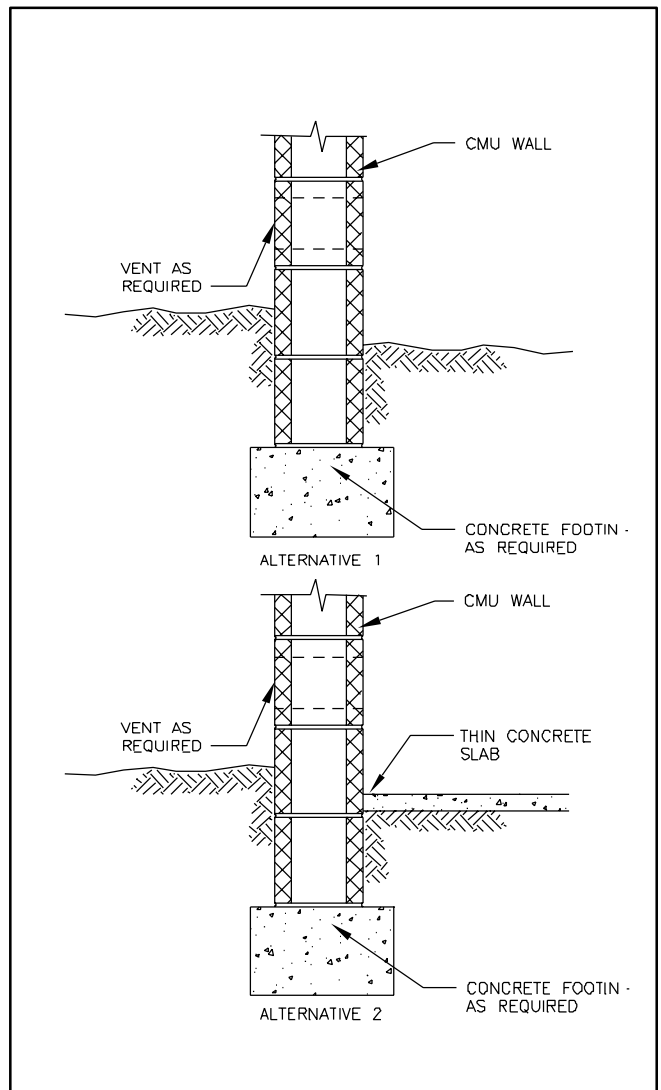

Figure 1-5: Crawl Space Wall

Crawl spaces may be constructed with a thin concrete slab but more likely have a soil or gravel covering with a vapor retarder. A crawl space foundation with a soil or

gravel covering does not require any special connections; the concrete masonry wall is simply a stem wall.

Crawl space walls are typically less than 4 feet in height with less than 3 feet of backfill; vertical reinforcement is not required as is sometimes required in basement wall construction. Venting of crawl spaces is required in the *International Residential Code*; however, it may be omitted in certain applications, particularly if a vapor retarder is provided and the foundation is adequately drained. Refer to the local building code to determine if venting is required and what options are approved to achieve satisfactory moisture control.

## FOOTINGS

The most common footing in residential construction is the continuous spread footing. Many building codes include tables prescribing the minimum footing width for concrete and masonry walls for a given building material, height, backfill height, and soil condition. Some general rules of thumb for sizing a residential concrete footing follow:

- ✓ The minimum footing thickness is one-third the total footing width or 6 inches, whichever is greater.
- ✓ The footing width projects a minimum of 2 inches from both sides of the wall, but not greater than the footing thickness.

The footing is commonly unreinforced except when located in high-wind or seismic areas, when stepped footings are used due to sloped sites, or when sites have difficult soil conditions. Although some designers may specify one or two longitudinal No. 4 bars for wall footings, steel reinforcement is usually not required for residential-scale structures in relatively stable soils.

In addition, some designers may specify a No. 4 vertical bar or dowel between the basement walls and footing at 4 to 8 feet on center. The dowel transmits the lateral soil loads from the wall to the footing; however, a concrete slab that abuts the base of the foundation wall provides enough lateral support in residential structures.

## RADON

Check the local building code to determine if radon-resistant construction is required. Typically radon-resistant construction measures require the builder to

- ✓ place a vapor retarder, such as polyethylene, beneath the concrete floor slab and on below-grade walls. If no concrete slab exists, place the retarder over the soil or gravel in the crawl space;
- ✓ ensure that the top course of the foundation wall is either solid or grouted solid; and
- ✓ seal penetrations in the slab and below-grade walls.

For more information on radon control methods and construction details for areas with elevated radon levels, refer to the Resources section.

## MOISTURE

Local building codes typically require basement walls to be dampproofed from the top of the footing to the finished grade. In areas where a high water table or other severe soil-water conditions are known to exist, exterior foundation walls enclosing habitable or storage space should be waterproofed with a membrane extending from the top of the footing to the finished grade. In crawl space construction, a vapor retarder should be placed over the soil and covered with a few inches of soil or gravel to reduce moisture problems. In most cases, the most important feature is good foundation and surface drainage. Refer to Figure 1-6 for recommendations regarding moisture and water control in below-grade foundations.

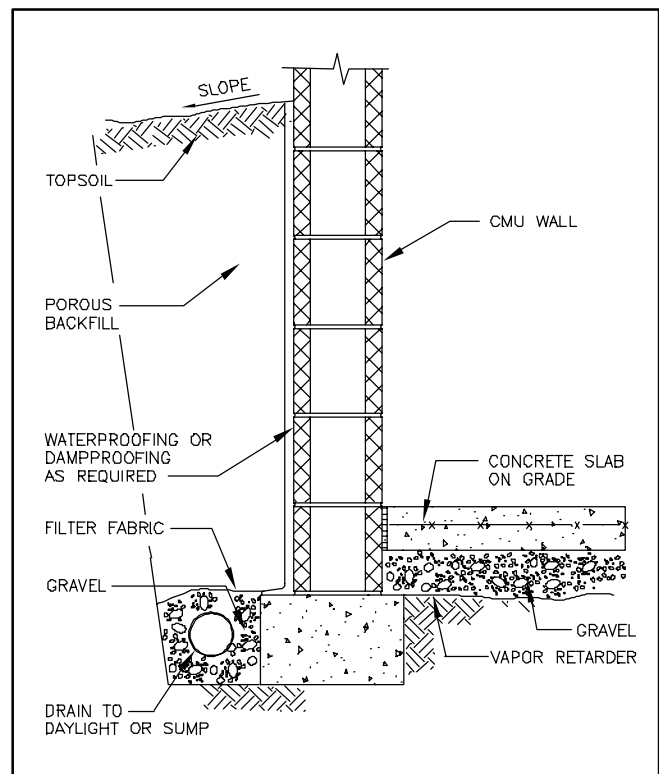

Figure 1-6: Moisture and Water Control Measures

## CONCLUSIONS

Good construction details are vital to the satisfactory performance of masonry residential structures.

The foregoing construction details are a compilation of recommended practices that not only resist structural forces and loads but also address moisture, movement, and other related issues that can compromise the integrity of a well-constructed home.

## RESOURCES

**NAHB Research Center, Inc.**  
400 Prince George's Boulevard  
Upper Marlboro, Maryland 20774-8731  
☎ 800.638.8556  
🌐 <http://www.nahbrc.org>



**National Concrete Masonry Association (NCMA)**

2302 Horse Pen Road  
Herndon, Virginia 20171-3499  
☎ 703.713.1900  
🌐 <http://www.ncma.org>

**Portland Cement Association (PCA)**

5420 Old Orchard Road  
Skokie, Illinois 60077-1083  
☎ 847.966.6200  
🌐 <http://www.portcement.org>

**U.S. Department of Housing and  
Urban Development (HUD)**

451 Seventh Street, S.W., Suite 8132  
Washington, DC 20410  
☎ 202.708.4370  
🌐 <http://www.hud.gov>

*Publications*

☎ 800.245.2691  
🌐 <http://www.huduser.org>

📖 ACI 530/ASCE 5/TMS 402, *Building Code Requirements for Masonry Structures*. American Concrete Institute (ACI), American Society of Civil Engineers (ASCE), and The Masonry Society (TMS), 1999.

📖 ASTM E1465, *Standard Guide for Radon Control Options for the Design and Construction of New Low-Rise Residential Buildings*. American Society for Testing and Materials (ASTM), draft.

📖 *International Residential Code*. International Code Council, Inc. (ICC), Falls Church, Virginia, 2000 (pending completion).



# Floor Connections

## FS · 2

An information series on residential concrete masonry technology

### SUMMARY

Connecting conventional and innovative floor systems to a concrete masonry wall may require some techniques that are unfamiliar to home builders. Although many proprietary floor systems are currently available, this fact sheet focuses first on common floor systems in homes constructed of standard dimensional lumber. Wood trusses, wood I-joists, cold-formed steel framing, steel bar joists, concrete block and joist systems, and precast concrete floor systems are also addressed. While steel bar joists and precast concrete floor systems are rare in single-family construction, they are included herein because they are used in multifamily construction. The several ways to connect the floor system to the wall are grouped into three categories as follows:

- ✓ direct-bearing connections;
- ✓ pocket connections; and
- ✓ ledger connections.

Light-frame builders may not be familiar with ledger and pocket connections. Such connections typically do not find much use in light-frame construction. However, ledger and pocket connections are not new to the building industry. For example, wood floor-to-masonry ledger and pocket connections were used in the United States during the 1700s, 1800s, and 1900s in residential masonry homes and continue to perform satisfactorily.

Similarly, residential builders may not be familiar with steel-frame or concrete floor systems. The construction details illustrated herein for steel-frame and concrete floor systems are similar to those details used in commercial construction.

*The details shown herein are “generic” and apply to typical wind and seismic areas (less than 110 mph, three-second-gust wind speed and less than Seismic Design Category D). It is suggested that the designer or builder consult the floor manufacturer before construction to determine if these generic details require modification when installing a proprietary floor system. Refer to local building codes and recognized standards for reinforcement and anchorage requirements. For additional requirements that may apply to special conditions, refer to the Resources section for more information.*

### CONNECTION TYPES

#### **Direct-Bearing Connection**

A direct-bearing connection is used when the wall below (i.e., foundation wall) does not continue to the story above or the wall below is wider than the wall above, providing a ledge with sufficient bearing area for the floor to bear on directly. The direct-bearing connection is the simplest and most familiar connection within the home building industry. The course of block on which the joists bear typically is a horizontal bond beam that ties the walls together in the story below; the bond beam is located at the top of each wall story.

#### **Pocket Connection**

A pocket connection is typically used when the wall below (i.e., foundation wall) continues to the story above the floor level without a change in wall thickness. The pocket connection consists of a void or “pocket” created in the wall by changing block placement or cutting into the block units after the wall is erected. The bearing surface on which the joists (or girders) bear typically is grouted solid creating a horizontal reinforced bond beam that ties together the walls in the story below.

The floor joist is then placed in the pocket providing a minimum amount of bearing, typically 3 to 4 inches. The local building code may require a wood floor joist to be fire cut to allow the floor joist to fall free from the wall in the event of fire.

Care must be taken to ensure that the use of a pocket does not adversely affect the strength of the wall. The pocket connections may interfere with the continuity of the vertical reinforcement in the wall. Rather than creating numerous pockets in a masonry wall for floor joists, a ledger connection or direct bearing connection is the preferred practice.

#### **Ledger Connection**

A ledger connection is used when the wall below continues at the same thickness to the story above the floor level or when the change in wall thickness does not allow for the minimum required bearing.

A ledger connection is often preferable to a pocket connection because the ledger board may be installed without affecting floor joist placement and does not require floor joist alignment with certain elements (i.e., pockets) of the wall. A ledger board, often preservative-treated 2x lumber, may be bolted to the concrete masonry wall after the wall is constructed. The mason may also grout the

anchor bolts in the wall while laying the block courses. Refer to Fact Sheet 7 (FS•7) for the various types of fasteners that can be used with concrete masonry.

## WOOD-FRAME FLOORS

Wood-frame floors are the most common type of floor system installed in residential construction. The floor may bear directly on a concrete masonry wall, it may be pocketed into the wall, or it may hang from the side of the concrete masonry wall.

Wood that is in direct contact with concrete masonry can potentially absorb moisture that may be present in the concrete masonry. To prevent decay, a moisture barrier (i.e., polyethylene sheet, sill sealer, felt, and galvanized sheet metal flashing) should be placed between the wood and the masonry. In lieu of using a moisture barrier, wood in direct contact with masonry must be either preservative-treated or of a durable species to prevent decay.

### Standard Dimensional Lumber

Figures 2-1 through 2-3 illustrate some recommended methods for connecting wood-frame floors to concrete masonry walls.

Standard dimensional lumber used for residential floor systems is most often nominal 2 x 8s, 2 x 10s, or 2 x 12s, depending on span and loading conditions. In high-wind (i.e., greater than 110 mph, three-second-gust) or high seismic areas (i.e., Seismic Design Category D), additional metal connectors are often necessary.

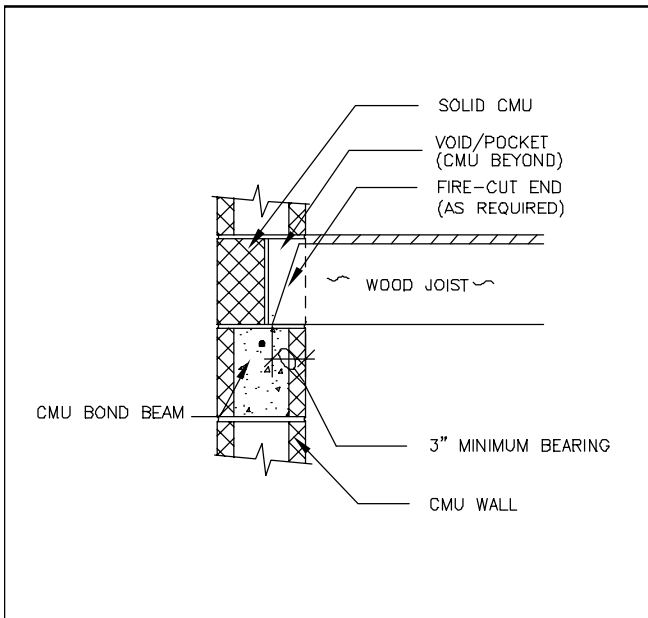

Figure 2-1: Wood Floor Pocket Connection

### Wood Trusses

Wood trusses, also known as metal plate connected wood trusses, are becoming more popular because of their consistent quality, competitive pricing in many areas, and capability of spanning long distances. Wood trusses are most often fabricated of nominal 2-inch-thick standard dimensional lumber. They are designed by a truss manufacturer for given span and loading conditions.

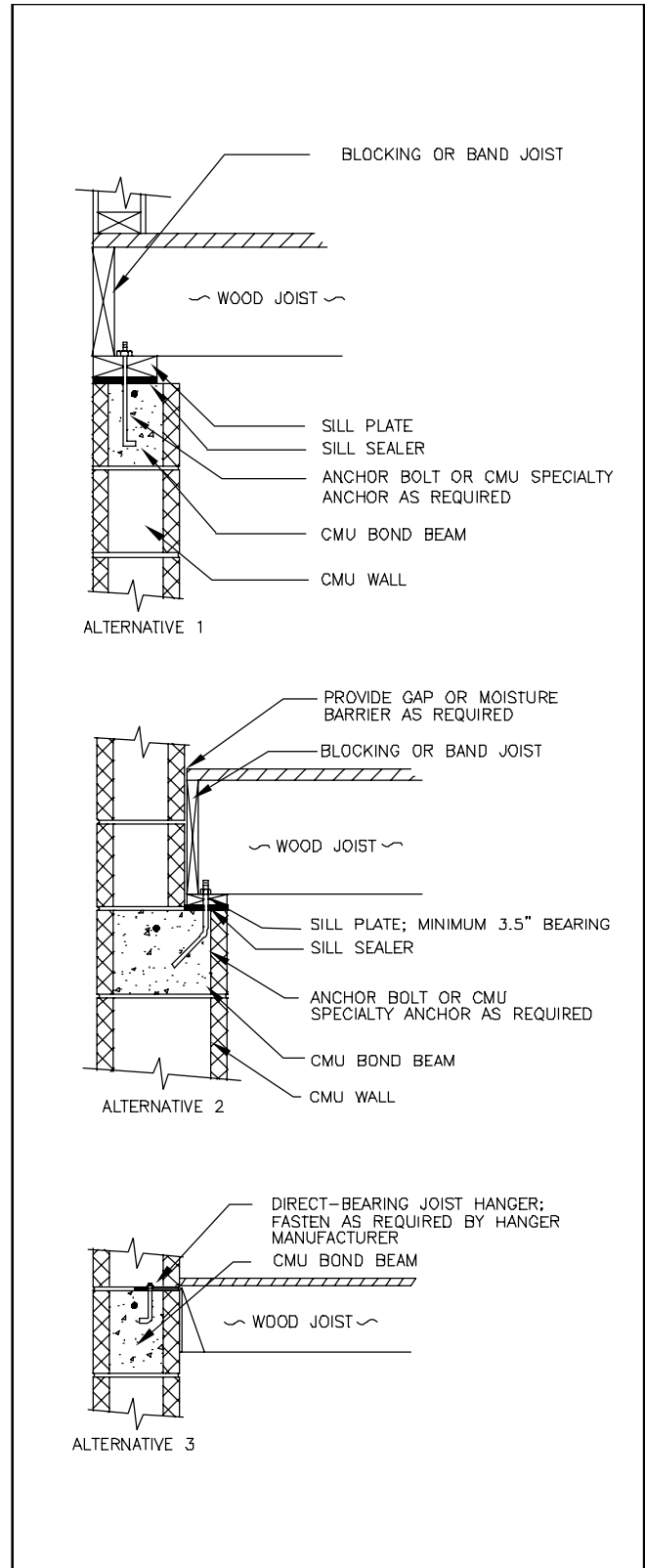

Figure 2-2: Wood Floor Direct-Bearing Connections

The recommended methods for connecting wood trusses to concrete masonry walls are similar to those for standard dimensional lumber; refer to Figures 2-1 and 2-2. Additionally, Figures 2-4 and 2-5 illustrate some recommended methods for connecting wood floor trusses to concrete masonry walls by using direct-bearing or pocket connections. Consult the Resources section for more information and standard details on wood trusses.

In high-wind (i.e., greater than 110 mph, three-second-gust) or high seismic areas (i.e., Seismic Design Category D), an additional metal connector is often necessary.

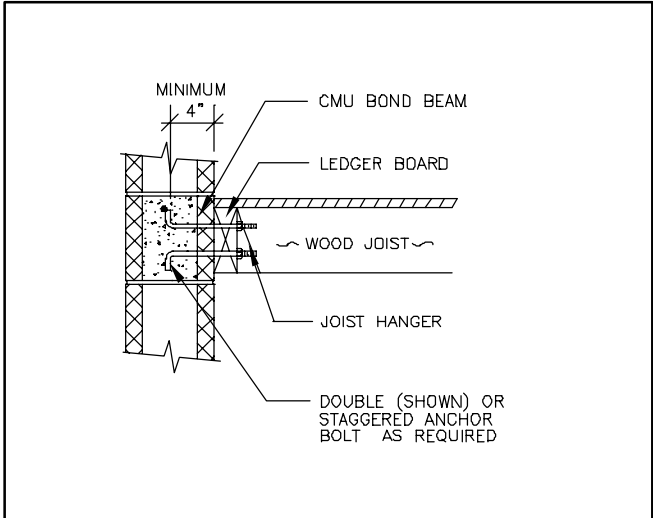

Figure 2-3: Wood Floor Ledger Connection

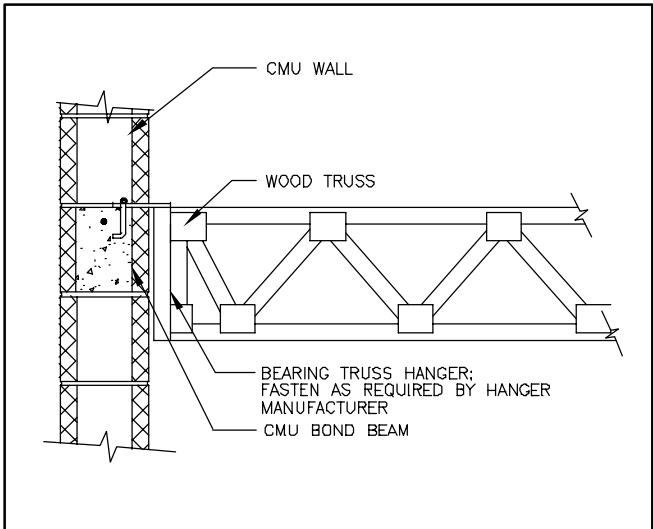

Figure 2-4: Wood Truss Floor Direct-Bearing Connection

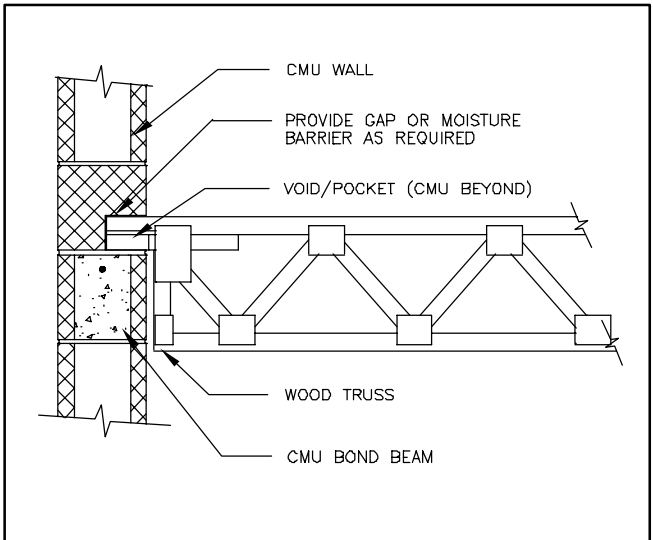

Figure 2-5: Wood Truss Floor Pocket Connection

**Wood I-Joists**

Wood I-joists are also very popular because of their consistent quality and capability of spanning relatively long distances. Wood I-joists resemble steel I-beams and are typically manufactured using plywood or oriented strand board for the web and solid sawn lumber for the flanges.

The recommended methods for connecting wood I-joists to concrete masonry walls are similar to those for standard dimensional lumber; refer to Figures 2-1 through 2-3. Consult the I-joist manufacturer for other possible methods of connecting wood I-joists to concrete masonry walls.

In high-wind (i.e., greater than 110 mph, three-second-gust) or high seismic areas (i.e., Seismic Design Category D), an additional metal connector is often necessary.

**STEEL**

Steel-frame floors are common in commercial structures because they are capable of spanning long distances. In addition, steel-frame floors may be used in residential construction.

Steel-frame floors most often bear directly on the wall below or are pocketed into the masonry wall; however, they may also be attached to the masonry wall by a ledger board or steel angle.

**Cold-Formed Steel Framing**

Cold-formed steel framing members are typically C-shaped with width and depth dimensions similar to solid sawn lumber. The framing members are placed at 16 or 24 inches on center. Cold-formed steel framing is installed much like solid sawn lumber.

To prevent corrosion, cold-formed steel that is in direct contact with concrete masonry requires a moisture barrier (i.e., polyethylene sheet, sill sealer, felt, and galvanized sheet metal flashing) placed between the steel and the masonry.

Figures 2-6 and 2-7 illustrate some recommended methods for connecting cold-formed steel-frame floors to concrete masonry walls by using a direct-bearing connection or a ledger board connection. In high-wind (i.e., greater than 110 mph, three-second-gust) or high seismic areas (i.e., Seismic Design Category D), an additional metal connector is often necessary.

Figure 2-6 shows the cold-formed steel floor framing attached directly to the concrete masonry wall; however, some builders prefer to install a wood sill plate on the concrete masonry wall and then attach the cold-formed steel framing to the wood. The cold-formed steel floor framing shown in Figure 2-7 is attached directly to the concrete masonry wall; however, wood may be used for this connection. As for the ledger board connection, some builders prefer to fasten the steel track to a preservative-treated wood ledger board before bolting to the wall, or they may choose to bolt a wood ledger board to the wall and then fasten the joist track to the wood ledger board. The use of wood with the cold-formed floor system is a matter of preference; refer to the Resources section for more information on cold-formed steel floor framing.

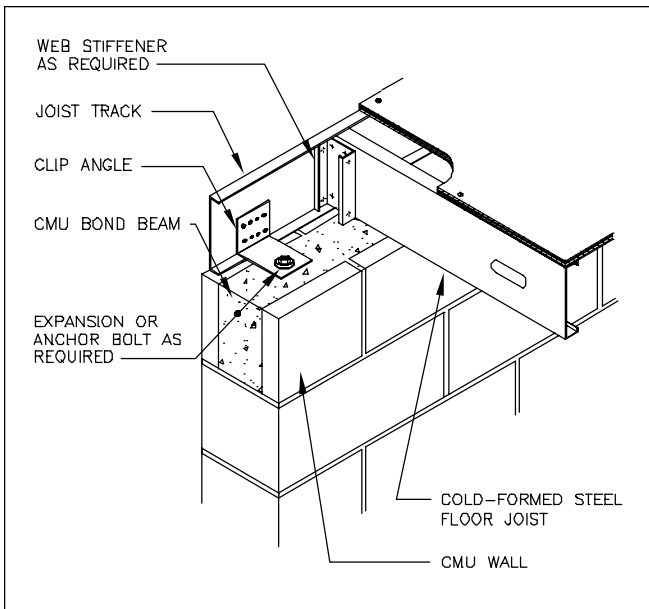

Figure 2-6: Cold-Formed Steel Floor Direct-Bearing Connection

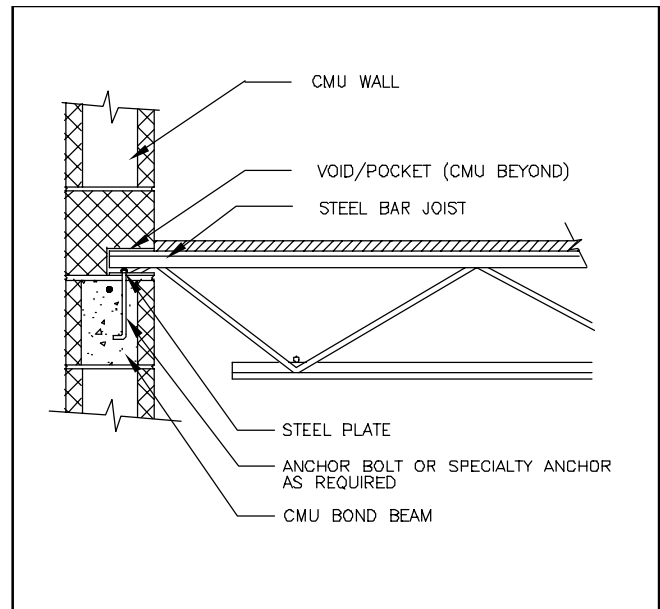

Figure 2-8: Steel Joist Floor Direct-Bearing Connection

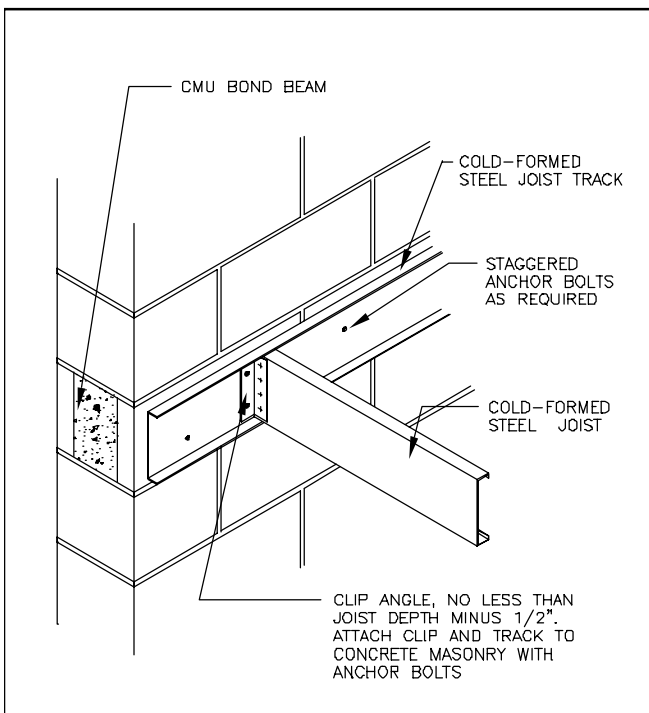

Figure 2-7: Cold-Formed Steel Floor Ledger Connection

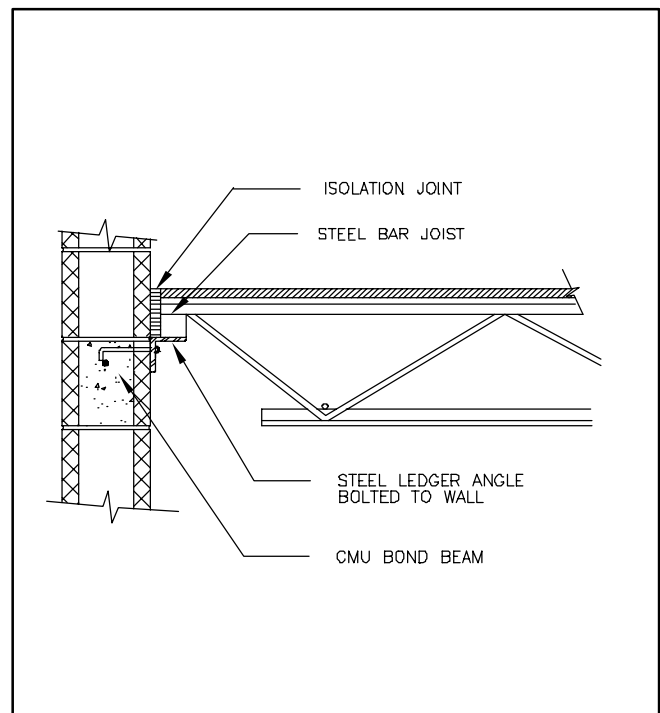

Figure 2-9: Steel Joist Floor Ledger Connection

## Steel Bar Joists

Steel bar joists are open web joists that are capable of long spans. They are designed to bear directly onto or be pocketed into a concrete masonry wall. In some areas, a steel ledger angle is bolted to the masonry while the steel bar joists bear on the steel angle. The steel angle ledger connection typically eliminates the need for masons to form pockets in the wall; thereby reducing the cost of constructing the concrete masonry wall.

Figures 2-8 and 2-9 illustrate some recommended methods for connecting the steel bar joist to a concrete masonry wall. Steel bar joists typically require 3 to 4 inches of bearing and should be fastened to the wall to provide floor support.

## CONCRETE MASONRY

A few currently available floor systems use concrete masonry while some rely on precast concrete joists or steel bar joists; however, other materials may be used in conjunction with the concrete masonry unit. One system currently available is the Block Joist® System. The Block Joist® System is a composite system that is constructed with concrete blocks placed side by side on patented steel bar joists. The bar joists rest on a ledge within the wall. Figure 2-10 illustrates how the block and steel bar joists interlock to form the finished floor. Some builders are using this type of floor system for heavy floor applications, such as a garage over a basement. Refer to the Resources section to

obtain manufacturer information and installation instructions.

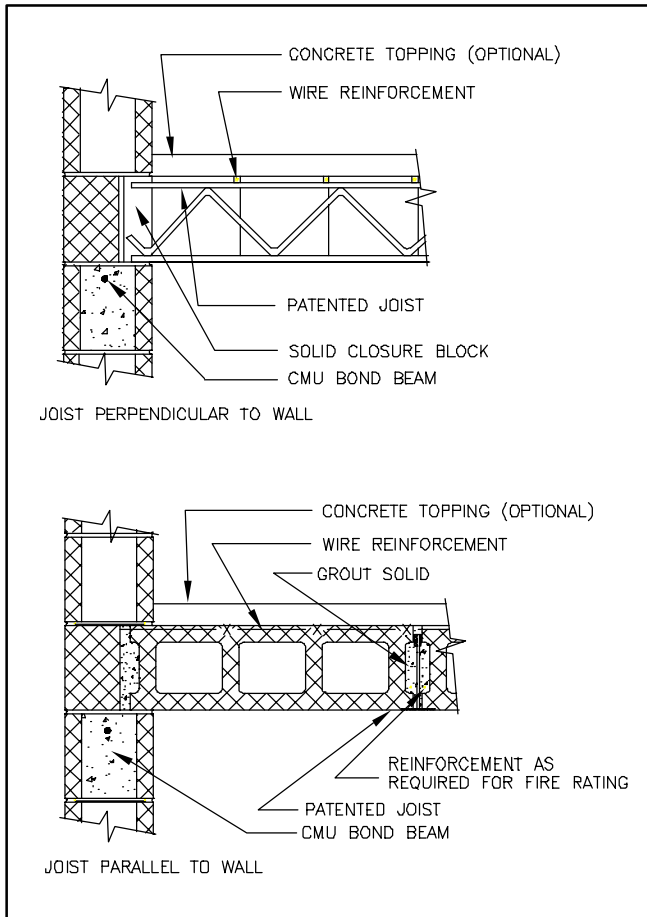

Figure 2-10: Block Joist<sup>®</sup> Floor System

## CONCRETE

Concrete floors are common in residential construction as ground-level floors (i.e., slab on grade). Due to placement and cost concerns; however, elevated concrete floors in residential construction are not common.

Precast or cast-in-place concrete is typically used in commercial construction because it is fire-resistant, capable of long spans (i.e., greater than 16 feet), sound deadening, and is resistant to rot and termite attack. It is also used in multifamily housing.

### Precast Concrete

Precast concrete floor systems come in concrete segments in a variety of widths, thicknesses, and lengths depending on clear span and design loading conditions. In residential construction, floor segments are most often 8-inch-thick hollow core panels 4 or 8 feet wide.

The precast concrete segments are often installed on continuous ledges in a concrete masonry wall that provides minimum bearing and does not create discontinuities in the exterior wall surface.

Figure 2-11 illustrates some recommended methods for connecting the precast concrete floor segments to a concrete masonry wall by using direct-bearing connections. Pocket connections are not feasible and ledger connections are not

common; therefore, pocket and ledger connections are not discussed herein.

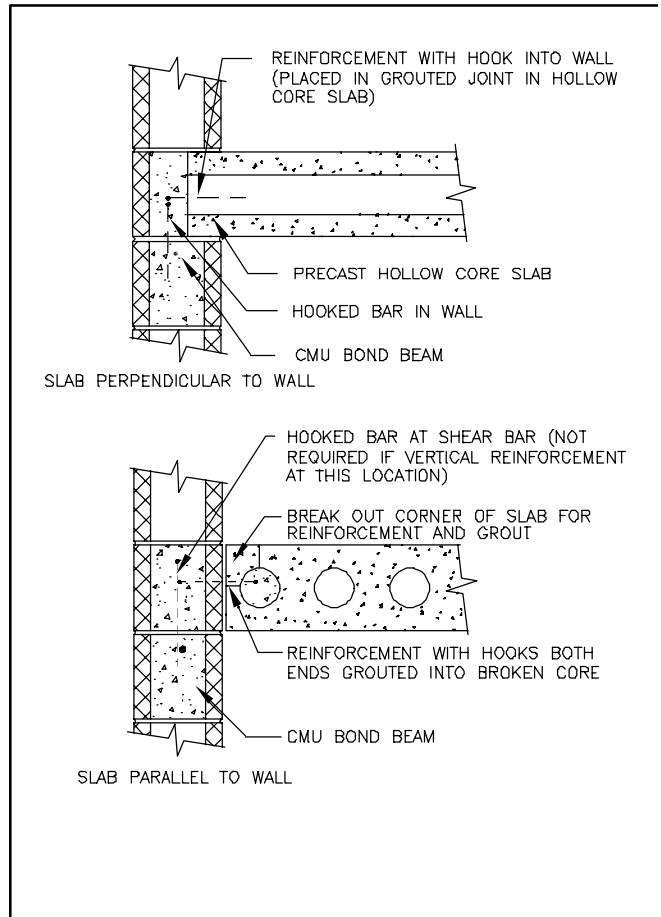

Figure 2-11: Precast Concrete Floor Direct-Bearing Connection

## CONCLUSIONS

Good construction details are vital to the satisfactory performance of residential structures. Several floor systems are available today; however, there are only three basic floor-to-wall connections as discussed herein.

The foregoing construction details are a compilation of recommended practices that not only resist structural forces and loads but also address moisture, movement, and other related issues that can compromise the integrity of a well-constructed home. These recommended practices focus on some of the more common floor connections used in single- and multi-family construction.

## RESOURCES

**American Forest and Paper Association (AF&PA)**  
 1111 19th St., NW, Suite 800  
 Washington, DC 20036  
 ☎ 202.463.2700  
 🌐 <http://www.afandpa.org>

**American Plywood Association (APA)**  
 P.O. Box 11700  
 Tacoma, Washington 98411  
 ☎ 253.565.6600  
 🌐 <http://www.apawood.org>

**BLOCK JOIST<sup>0</sup> Company, LLC**

109 Ralston Road  
Richmond, Virginia 23229  
☎ 804.285.1250

**NAHB Research Center, Inc.**

400 Prince George's Boulevard  
Upper Marlboro, Maryland 20774-8731  
☎ 800.638.8556  
🌐 <http://www.nahbrc.org>

**National Concrete Masonry Association (NCMA)**

2302 Horse Pen Road  
Herndon, Virginia 20171-3499  
☎ 703.713.1900  
🌐 <http://www.ncma.org>

**North American Steel Framing Alliance (NASFA)**

1726 M Street, N.W., Suite 601  
Washington, DC 20036-4523  
☎ 202.785.2022  
🌐 <http://www.steel framing alliance.com>

**Portland Cement Association (PCA)**

5420 Old Orchard Road  
Skokie, Illinois 60077-1083  
☎ 847.966.6200  
🌐 <http://www.portcement.org>

**Precast/Prestressed Concrete Institute (PCI)**

175 West Jackson Boulevard, Suite 1859  
Chicago, Illinois 60604  
☎ 312.786.0300  
🌐 <http://www.pci.org>

**Steel Joist Institute (SJI)**

3127 10th Avenue, North Ext.  
Myrtle Beach, South Carolina 29577-6760  
☎ 843.626.1995  
🌐 <http://www.steeljoist.com>

**U.S. Department of Housing and  
Urban Development (HUD)**

451 Seventh Street, S.W., Suite 8132  
Washington, DC 20410  
☎ 202.708.4370  
🌐 <http://www.hud.gov>

*Publications*

☎ 800.245.2691  
🌐 <http://www.huduser.org>

**Wood Truss Council of America (WTCA)**

6425 Normandy Lane  
Madison, Wisconsin 53719-1133  
☎ 608.274.4849  
🌐 <http://www.woodtruss.com>

📖 ACI 530/ASCE 5/TMS 402, *Building Code Requirements for Masonry Structures*. American Concrete Institute (ACI), American Society of Civil Engineers (ASCE), and The Masonry Society (TMS), 1999.

📖 *Builders Guide to Residential Steel Floor Framing*. prepared by the NAHB Research Center, Inc., for the U.S. Department of Housing and Urban Development, Washington, DC, 1999.

📖 *International Residential Code*. International Code Council, Inc. (ICC), Falls Church, Virginia, 2000 (pending completion).

📖 *National Design Standard for Metal Plate Connected Wood Truss Construction*. Truss Plate Institute, Madison, Wisconsin, 1995.

📖 *Prescriptive Method for Residential Cold-Formed Steel Framing, Third Edition*. NAHB Research Center, Inc., Upper Marlboro, Maryland, 1998.

📖 *Metal Plate Connected Wood Truss Handbook*. Wood Truss Council of America (WTCA), Madison, Wisconsin, 1994.



# Roof Connections

## FS · 3

An information series on residential concrete masonry technology

### SUMMARY

Single-family residential roof systems are most often constructed of lumber; however, steel roof systems are also used in certain areas of the country. Concrete roof systems are used in some multifamily construction. Concrete masonry roof systems are relatively new to the market and are being used by some builders in single-family custom homes. All these roof systems are discussed herein.

Connecting a roof system to a concrete masonry wall is similar to connecting a floor system to a concrete masonry foundation wall in that most roof systems bear directly on the walls below.

While many proprietary roof systems are currently available, this fact sheet focuses on common roof systems constructed of standard dimensional lumber, wood trusses, cold-formed steel framing, steel bar joists, concrete block joists, and precast concrete roof systems. In addition, there may be more than one way to connect the roof system to a wall; these connections are grouped into the following three categories:

- ✓ direct-bearing connections;
- ✓ pocket connections; and
- ✓ ledger connections.

The most popular connections are direct-bearing connections. Light-frame builders may not be as familiar with ledger and pocket connections; those connections typically are not used in light-frame construction. Ledger and pocket connections are not, however, new to the building industry. For example, wood roof-to-masonry wall pocket and ledger connections were used in residential masonry homes in the United States during the 1700s, 1800s, and 1900s and continue to perform satisfactorily.

Similarly, residential builders may not be familiar with steel-frame or concrete roof systems. The construction details illustrated herein for steel-frame and concrete flooring systems are similar to those details used in commercial construction.

*The details shown herein are “generic” and apply to typical low-wind and seismic areas (less than 110-mph, three-second-gust wind speed and less than Seismic Design Category D). It is suggested that the designer or builder consult the roof manufacturer before construction to determine if these generic details require modification when installing a proprietary roof system. Refer to local building codes and recognized standards for reinforcement and anchorage requirements. For additional requirements that*

*may apply to special conditions, refer to the Resources section for more information.*

*Multifamily or attached single-family construction often uses a parapet wall to achieve fire-rated assemblies between dwelling units. (A parapet is the segment of wall that continues beyond the roof level.) However, parapet walls are typically parallel to the span of the roof system; therefore, this fact sheet focuses only on direct-bearing connections.*

### DIRECT-BEARING CONNECTION

A direct-bearing connection is used in instances where the wall below does not continue beyond the roof level (i.e., no parapet). It is also used when the wall below provides a ledge with sufficient bearing area for the roof to bear on directly. The direct-bearing connection is the simplest and most common connection in the home building industry. The course of block on which the roof system bears typically is often a horizontal bond beam that ties together the walls in the story below.

### WOOD-FRAME ROOFS

Wood-frame roofs most often bear directly on the concrete masonry walls below. Wood that is in direct contact with concrete masonry can potentially absorb moisture that may be present in the concrete masonry. To prevent decay, a moisture barrier (i.e., polyethylene sheet, sill sealer, felt, and galvanized sheet metal flashing) should be placed between the wood and the masonry. In lieu of using a moisture barrier, wood in direct contact with masonry must be either preservative-treated or of a durable species to prevent decay.

### Standard Dimensional Lumber

The recommended methods for connecting wood-frame roofs to concrete masonry walls by direct-bearing connections are identical to those for wood truss connections; refer to Figure 3-1. Standard dimensional lumber used for residential roof systems is most often nominal 2 x 6s, 2 x 8s, 2 x 10s depending on span and loading conditions.

In high-wind (i.e., greater than 110 mph, three-second-gust) or high seismic areas (i.e., Seismic Design Category D), additional metal connectors are often necessary.

## Wood Trusses

Wood trusses, also known as metal plate-connected wood trusses, are popular for roof construction because of their competitive price, reduced labor requirements for roof framing, and ability to span long distances. Wood trusses are most often fabricated of nominal 2-inch standard dimensional lumber and designed by the truss manufacturer for given span and loading conditions.

Figure 3-1 illustrates some recommended methods for connecting wood roof trusses to concrete masonry walls by using direct-bearing connections. In high-wind (i.e., greater than 110 mph, three-second-gust) or high seismic areas (i.e., Seismic Design Category D), an extra metal connector is often necessary.

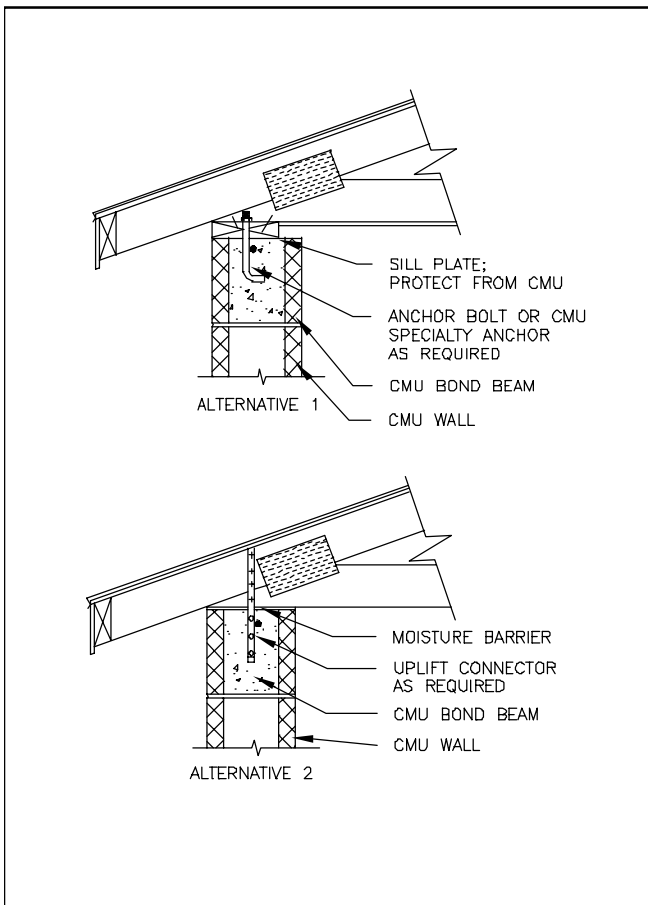

Figure 3-1: Wood Roof Truss (or Rafter) Direct-Bearing Connection

## Wood I-Joists

Wood I-joists are also popular because of their consistent quality and ability to span relatively long distances. Wood I-joists resemble steel I-beams and are typically manufactured using plywood or oriented strand board for the web and solid sawn lumber for the flanges.

The recommended methods for connecting wood I-joists to concrete masonry walls are similar to those for standard dimensional lumber; refer to Figure 3-1. Consult the I-joist manufacturer for other possible methods of connecting wood I-joists to concrete masonry walls. In high-wind (i.e., greater than 110 mph, three-second-gust) or high seismic areas (i.e., Seismic Design Category D), an additional metal connector is often necessary.

## STEEL

Steel-frame roofs are common in commercial structures. Steel-frame roofs are also used in multifamily construction involving long spans or in heavily infested termite areas.

Steel roofs most often bear directly on the walls below, although pocket and ledger connections may also be used. This section focuses on the direct-bearing connection, which is the most common connection in residential construction.

## Cold-Formed Steel Framing

Cold-formed steel framing is typically truss-built from C-shaped members, with width and depth dimensions similar to solid sawn lumber. The framing members are placed at 16 or 24 inches on center.

Figure 3-2 illustrates one recommended method for connecting cold-formed steel-frame roof systems to concrete masonry walls by using direct-bearing connections. In high-wind (i.e., greater than 110 mph, three-second-gust) or high seismic areas (i.e., Seismic Design Category D), an additional metal connector is often necessary.

Cold-formed steel trusses are also available from manufacturers and are shipped to the site already assembled much like wood trusses; however, most steel trusses are built on site. Figure 3-2 is also applicable to cold-formed steel trusses.

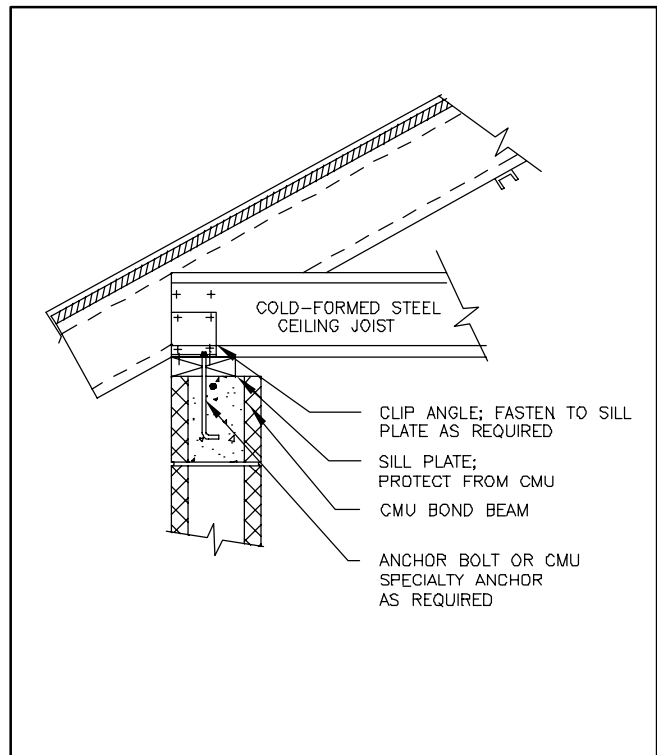

Figure 3-2: Cold-Formed Steel Roof Direct-Bearing Connection

## Steel Bar Joists

Steel bar joists are open web joists that are capable of long spans. They are designed to bear directly on or to be pocketed into concrete masonry walls. In some areas, a steel ledger angle is bolted to the masonry wall such that the steel bar joists bear on the steel angle. The steel angle ledger connection is sometimes used to eliminate the need for

masons to form pockets in the wall, thereby reducing the cost of constructing concrete masonry walls. Steel bar joists may be used to construct either a flat or slightly sloped roof system.

Figures 3-3 and 3-4 illustrate some recommended methods for connecting the steel bar joist to a concrete masonry wall. Steel bar joists typically require 3 to 4 inches of bearing and should be fastened to the wall to provide anchorage for uplift and lateral forces.

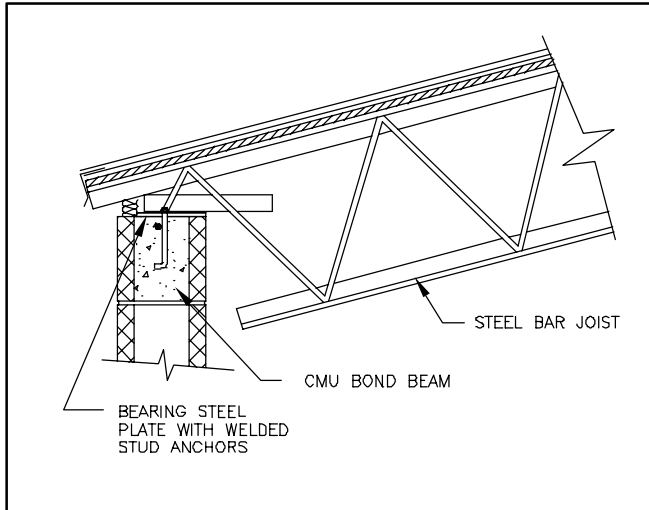

Figure 3-3: Steel Bar Joist Roof Direct-Bearing Connection

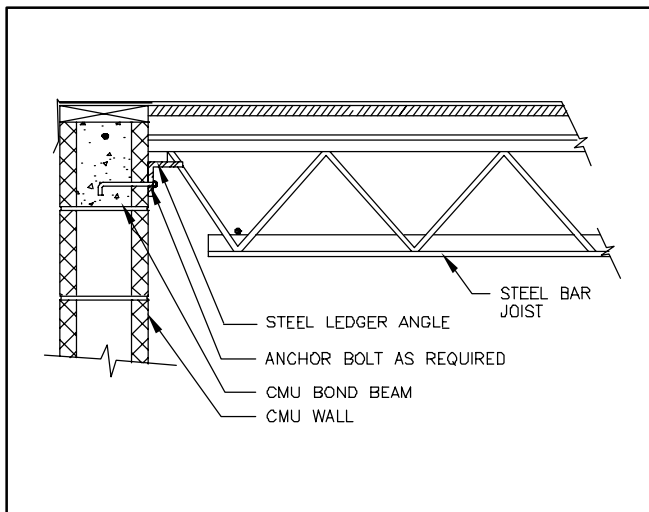

Figure 3-4: Steel Bar Joist Roof Ledger Connection

## CONCRETE MASONRY

A few currently available roof systems use concrete masonry while some rely on precast concrete joists or steel bar joists; however, other materials may be used in conjunction with the concrete masonry. One system currently available is the Block Joist® System, which relies on steel bar joists for support. The Block Joist® System is a composite system that is constructed with concrete blocks placed side by side on patented steel bar joists. The bar joists rest on a ledge within the wall. Figure 3-5 illustrates how the block and steel bar joists interlock to form the finished roof deck. Some builders are using this type of roof system for patio roof deck applications where strength is

desired. Refer to the Resources section to obtain manufacturer information and installation instructions.

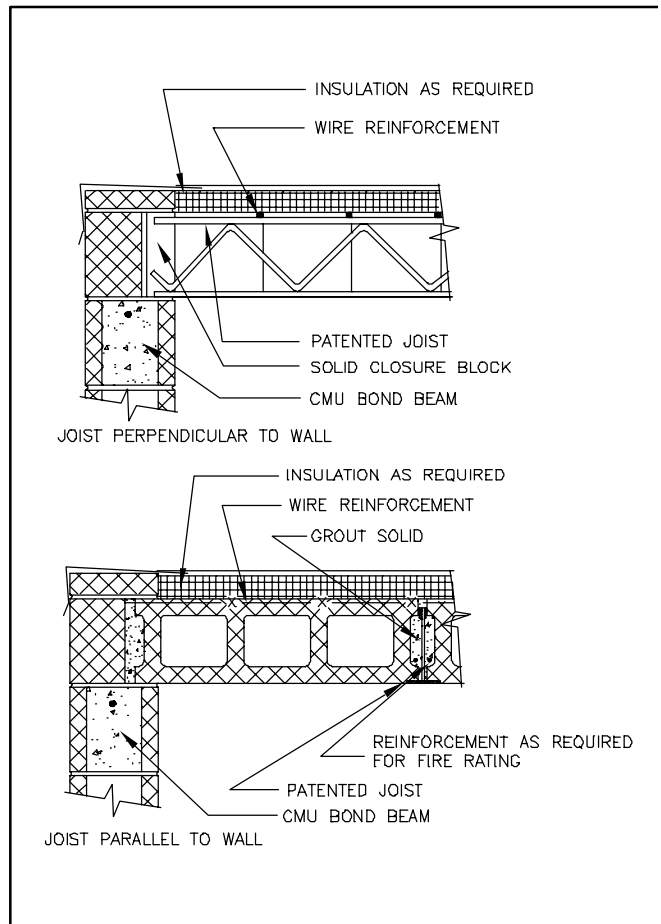

Figure 3-5: Block Joist® Roof System

## CONCRETE

Concrete roofs are not common in single-family residential construction, but they are used in multifamily residential construction.

Precast or poured-in-place concrete is typically used in commercial construction because it is capable of spanning long distances and is resistant to rot and termite attack.

### Precast Concrete

Precast concrete roof systems come in concrete segments in a variety of widths, thicknesses, and lengths depending on clear span and design loading conditions. In residential construction, roof segments are most often 8-inch-thick hollow core panels, 4 or 8 feet wide.

Precast concrete segments are usually installed on continuous ledges in a concrete masonry wall that provides minimum bearing.

Figure 3-6 illustrates some recommended methods for connecting the precast concrete roof segments to a concrete masonry wall by using direct-bearing connections. Pocket connections are not practical and ledger connections are not common; therefore, pocket and ledger connections are not discussed herein.

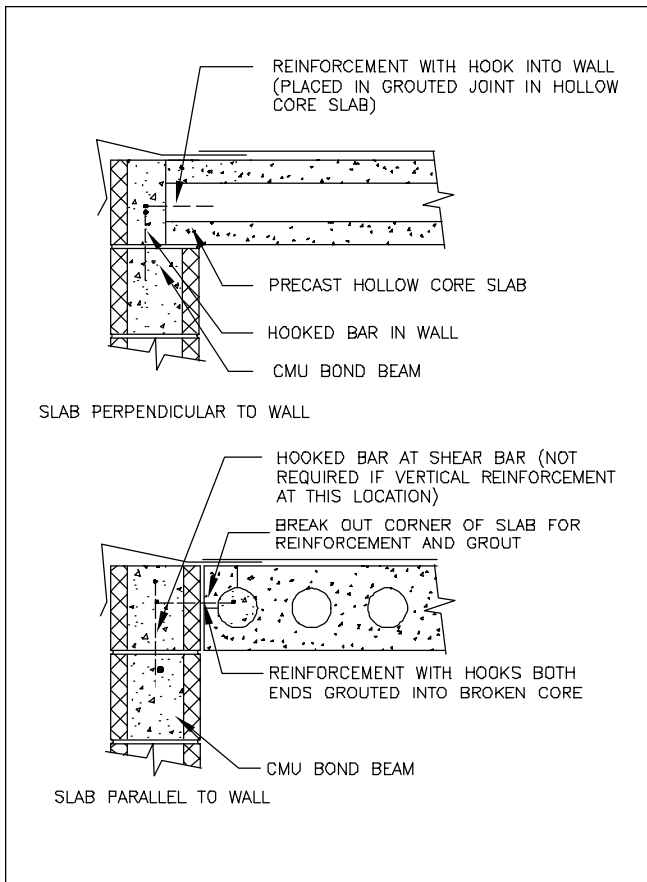

Figure 3-6: Precast Concrete Roof System

## CONCLUSIONS

Good construction details are vital to the satisfactory performance of residential structures. Several roof systems are available in today's market.

The foregoing construction details are a compilation of recommended practices intended to ensure that residences resist structural forces and loads. They also address movement and other related issues that compromise the integrity of a well-constructed home. These recommended practices focus on some of the more common roof connections used in single- and multi-family construction.

## RESOURCES

### American Forest and Paper Association (AF&PA)

1111 19th St., NW, Suite 800  
Washington, DC 20036  
☎ 202.463.2700  
🌐 <http://www.afandpa.org>

### American Plywood Association (APA)

P.O. Box 11700  
Tacoma, Washington 98411  
☎ 253.565.6600  
🌐 <http://www.apawood.org>

### BLOCK JOIST<sup>®</sup> Company, LLC

109 Ralston Road  
Richmond, Virginia 23229  
☎ 804.285.1250

### NAHB Research Center, Inc.

400 Prince George's Boulevard  
Upper Marlboro, Maryland 20774-8731  
☎ 800.638.8556  
🌐 <http://www.nahbrc.org>

### National Concrete Masonry Association (NCMA)

2302 Horse Pen Road  
Herndon, Virginia 20171-3499  
☎ 703.713.1900  
🌐 <http://www.ncma.org>

### North American Steel Framing Alliance (NASFA)

1726 M Street, N.W., Suite 601  
Washington, DC 20036-4523  
☎ 202.785.2022  
🌐 <http://www.steel framingalliance.com>

### Portland Cement Association (PCA)

5420 Old Orchard Road  
Skokie, Illinois 60077-1083  
☎ 847.966.6200  
🌐 <http://www.portcement.org>

### Precast/Prestressed Concrete Institute (PCI)

175 West Jackson Boulevard, Suite 1859  
Chicago, Illinois 60604  
☎ 312.786.0300  
🌐 <http://www.pci.org>

### Steel Joist Institute (SJI)

3127 10th Avenue, North Ext.  
Myrtle Beach, South Carolina 29577-6760  
☎ 843.626.1995  
🌐 <http://www.steeljoist.com>

### U.S. Department of Housing and Urban Development (HUD)

451 Seventh Street, S.W., Suite 8132  
Washington, DC 20410  
☎ 202.708.4370  
🌐 <http://www.hud.gov>  
*Publications*  
☎ 800.245.2691  
🌐 <http://www.huduser.org>

### Wood Truss Council of America (WTCA)

6425 Normandy Lane  
Madison, Wisconsin 53719-1133  
☎ 608.274.4849  
🌐 <http://www.woodtruss.com>



ACI 530/ASCE 5/TMS 402, *Building Code Requirements for Masonry Structures*. American Concrete Institute (ACI), American Society of Civil Engineers (ASCE), and The Masonry Society (TMS), 1999.



*International Residential Code*. International Code Council, Inc. (ICC), Falls Church, Virginia, 2000 (pending completion).



*National Design Standard for Metal Plate Connected Wood Truss Construction.* Truss Plate Institute, Madison, Wisconsin, 1995.



*Prescriptive Method for Residential Cold-Formed Steel Framing, Third Edition.* NAHB Research Center, Inc., Upper Marlboro, Maryland, 1998.



*Metal Plate Connected Wood Truss Handbook.* Wood Truss Council of America (WTCA), Madison, Wisconsin, 1994.



# Finish Attachments

FS · 4

An information series on residential concrete masonry technology

## SUMMARY

Finishes on many of the homes built in the United States are vinyl, brick veneer, wood, or stucco on the exterior and drywall or plaster on the interior. Although most homes in the United States are light-frame, these same finishes can also be installed on concrete masonry homes. In some cases, the finish system can be installed more quickly and less expensively than on light-frame homes. Home builders, however, may be unfamiliar with techniques for fastening the various finishes to concrete masonry walls.

This fact sheet focuses on general attachment details for common finish materials to concrete masonry walls. Specific tools and fasteners used to connect the finishes to the concrete masonry wall are covered in Fact Sheet 7 (FS•7). Leaving the concrete masonry wall exposed is also discussed herein.

Also of interest are requirements for moisture control (i.e., weather barrier) on masonry walls. Where weather-barriers are typically required, it is shown in the illustration. Weather-barriers allow moisture vapors to escape. Moisture, while not posing a threat to the strength of concrete masonry, may adversely affect finish and insulation systems as well as utilities. Refer to the specific finish manufacturer's technical information to determine what types of weather barriers, if required, are permitted.

As with light-frame construction, proper flashing is necessary to prevent water intrusion. Flashing should be installed around openings before the installation of finish systems.

The details shown herein are "generic". Many finish manufacturers have warranties that become void if installation does not comply with manufacturers' installation instructions. The illustrations in this fact sheet do not include guidance on the installation of flashing, window and door selection and installation, and caulking since it is not only dependent on the finish system, but also the specific finish manufacturer. As a result, it is suggested that the designer or builder consult the finish manufacturer before construction to determine what modifications are required.

## EXPOSED CONCRETE BRICK OR BLOCK

The size of a "traditional" concrete masonry unit is nominally 4, 6, 8, 10, or 12 inches wide, 8 inches high, and 16 inches long. The units are typically gray with a flat finish and are usually hollow or sometimes solid. These "traditional" units are often used in residential construction to construct foundation walls. When units are used to

construct above-grade walls, builders must consider how to attach finishes to concrete masonry walls. However, exposed concrete masonry need not be gray, flat, or 8- by 16-inch modules. Today, concrete masonry units are manufactured in a wide variety of shapes, sizes, colors, and textures. Figure 4-1 illustrates various concrete blocks that are now available.

Units are also readily available in nominal 4- or 8-inch heights and nominal 8- or 16-inch lengths. These types of block are available as hollow (shown) or as solid units. Hollow units are used to construct structural walls and are available in larger widths. Hollow and solid units are installed in the same manner as traditional gray concrete blocks.

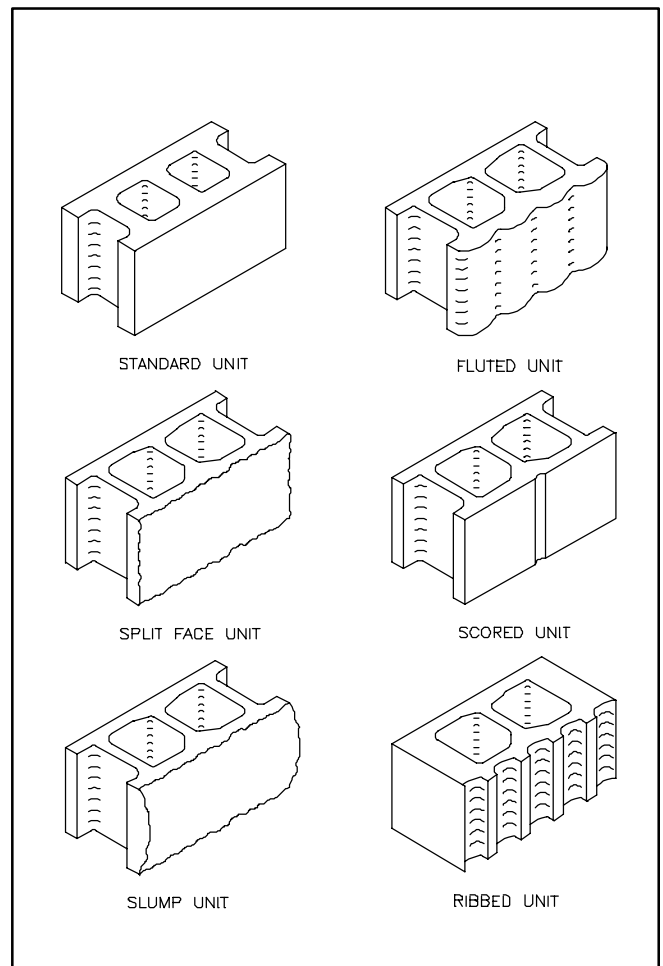

Figure 4-1: Hollow Concrete Masonry Units

Multi-colored, multitextured units are more attractive to designers, home owners, and builders than the "traditional"

gray units. A color may be used for an entire wall or designs may be created by using more than one color.

Concrete masonry units available are split-faced, slumped, fluted, ribbed, and scored. Split-faced blocks are split lengthwise by a machine to produce a rough, stone-like texture. Slump blocks are manufactured by squeezing the block after it is formed to create a bulging effect. Fluted, ribbed, and scored blocks are formed with vertical flutes, ribs, or striations that align during wall construction to give the appearance of a wall constructed of smaller units. Refer to the Resources section for more information on available shapes and sizes.

Concrete bricks may be manufactured at 3-5/8 inches wide by 2-1/4 inches high by 7-5/8 inches long -- dimensions identical to clay brick. Concrete brick may also be manufactured at 3-5/8 inches wide by 2-1/4 inches high by 15-5/8 inches long. Concrete brick veneer supports only its own weight and is anchored to a concrete masonry wall by corrosion-resistant metal ties. Refer to the local building code for the horizontal and vertical spacing requirements for brick metal ties. Figures 4-2 and 4-3 illustrate methods of anchoring concrete brick veneer to concrete masonry walls. Conventional corrugated brick ties may also be used in lieu of the ladder-type wall tie shown in Figures 4-2 and 4-3.

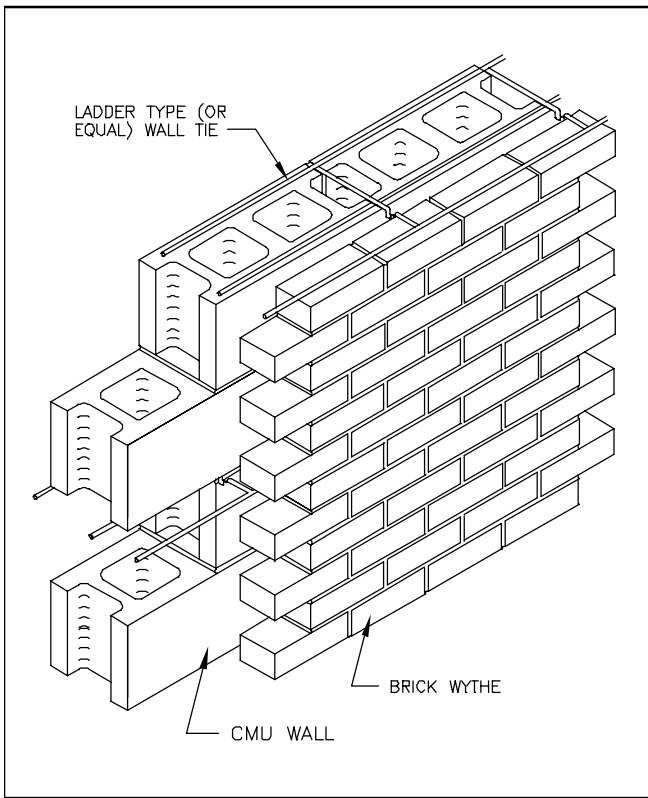

Figure 4-2: Brick Veneer (Cavity Wall)

Concrete brick is also available as a patented, tongue-and-groove interlocking concrete brick system installed in a manner similar to bevel siding. Figures 4-4a and 4-4b illustrate the interlocking concrete brick and its installation. Refer to the Resources section to obtain manufacturer information.

In single-wythe concrete masonry wall construction exposed to the weather, a water repellent is suggested. Water repellents provide resistance to wind-driven rain and protect the masonry from efflorescence and staining.

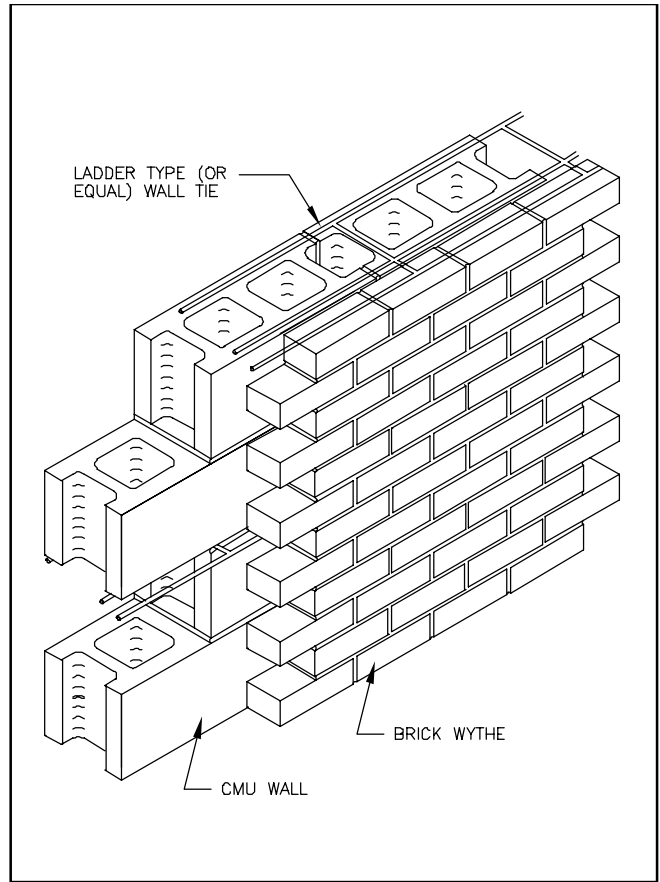

Figure 4-3: Brick Veneer (Composite Wall)



Figure 4-4a: Novabrik™ by the Allan Block Corporation

Water repellents may be surface applied after the wall is constructed or added during the manufacturing process as an admixture integral to the unit. Water repellents, whether surface applied or integral, come in a variety of colors, textures, and finishes (i.e., matte or glossy).

If used in the manufacture of masonry units, integral water repellents, should also be added to the mortar at the job site. Surface-applied water repellents should always be water vapor permeable, which means that they should allow water vapor in the wall to escape. If the water repellent does



not allow the concrete masonry wall to “breathe”, moisture can build up and cause the repellent to blister and peel. Surface repellents may be applied in addition to using an integral water repellent; however, check with the block manufacturer as well as the water-repellent manufacturer to ensure that the repellents are compatible.



Figure 4-4b: Novabrik™ by the Allan Block Corporation

## CLAY BRICK VENEER

Clay brick masonry has traditionally been popular as a veneer on wood frame homes. Common face bricks are typically 3-5/8 inches wide by 2-1/4 inches high by 7-5/8 inches long. Other sizes are available in some regions. The units can be either hollow or solid and come in many different shapes, sizes, textures, and colors.

Clay brick veneer supports only its own weight and is most commonly supported by a ledge in the foundation wall. Corrosion-resistant metal ties secure the veneer to concrete masonry walls. Refer to the local building code for horizontal and vertical spacing requirements for brick metal ties. Figures 4-2 and 4-3 illustrate methods for anchoring clay brick veneer to a concrete masonry wall. Conventional corrugated brick ties may also be used in lieu of the ladder-type wall tie shown in Figures 4-2 and 4-3.

Clay brick is also manufactured as a “thin brick”, measuring 1/2-inch wide, 2-1/4 inches high, and 7-5/8 inches long. These brick units are typically fastened to the concrete masonry wall with adhesive; mortar is then applied with a mortar gun between the bricks. The resulting wall has the appearance of a traditional brick veneer wall but at less expense.

Some systems that use the 1/2-inch-thick brick also provide a patented backer board that is fastened to the concrete masonry wall. The brick is then adhered to the backer board and the mortar joints filled with a mortar gun. The patented backer board typically provides some variation of a horizontal 3/8-inch spacer to allow faster and more uniform placement of the bricks. Figure 4-5 illustrates a 1/2-inch-thick clay brick veneer system on a concrete masonry wall.

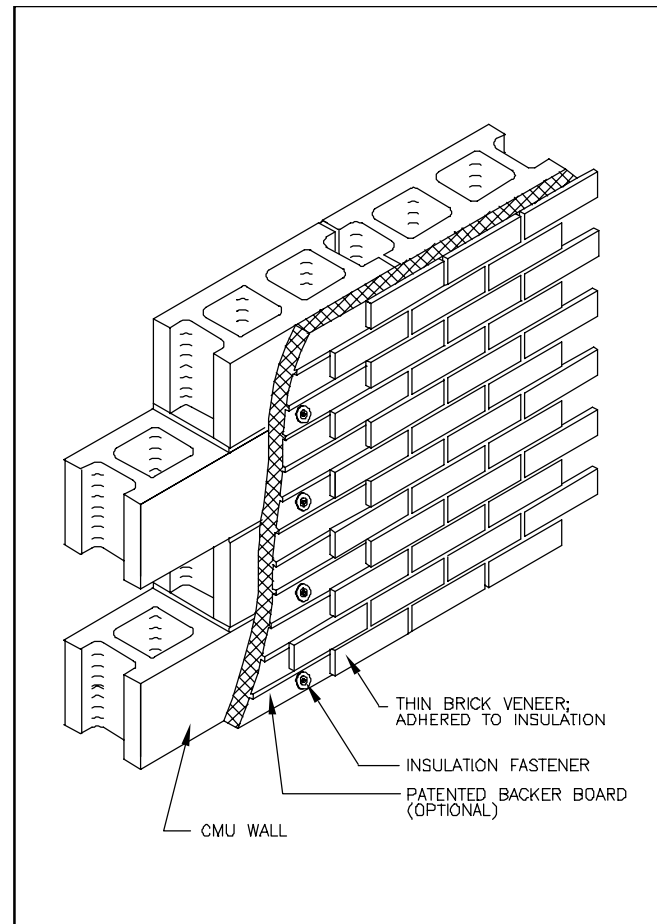

Figure 4-5: Patented Thin Brick Veneer

## STONE VENEER

Unless a home is a historic or custom residence, stone is typically used as a veneer on the entry facade, or as an accent, such as for a fireplace. Stone veneer is available in thin units, between 1 and 3 inches, and in a variety of colors, textures, sizes, and shapes. Figures 4-6 and 4-7 illustrate two methods of stone veneer installation.

Depending on the thickness and weight of each unit, stone veneer is typically installed in a manner similar to brick on a structural concrete masonry wall. One end of a corrosion-resistant anchor is inserted into the mortar joint of the stone and the other end into the mortar joint of the concrete masonry wall. For thinner (i.e., 1/4- to 5/8-inch-thick) and lighter stone veneer, a thin bed of mortar is applied directly to the surface of the concrete masonry wall. The stone veneer is placed in the bed of mortar and the joints between the stone units are grouted. Figure 4-6 illustrates the method of attaching natural stone veneer to a concrete masonry wall.

Cultured stone veneer is also available and is typically less expensive and lighter in weight than natural stone. Cultured stone veneer is cast in molds by using Portland cement, light-weight natural aggregates, and color pigments to produce units that look and feel like natural stone. The lightweight cultured stone units can be fastened to the concrete masonry wall with a thin layer (i.e., 3/8-inch-thick) of mortar. If the stone selected requires joints between each stone unit, the joints are then filled with mortar. Figure 4-7 illustrates cultured stone veneer on a concrete masonry wall.

## WOOD SIDING

Wood siding has been used for more than one hundred years in the United States and has traditionally taken the form of lap-board or bevel siding. It is manufactured to standard sizes and made by sawing plain-surfaced boards at a diagonal to produce two wedge-shaped pieces. The siding is about 3/16 inch thick at the thin edge and 1/2 to 3/4 inch thick at the other edge, depending on the width of the piece. Refer to Figure 4-8, which illustrates the attachment of wood siding to a concrete masonry wall.

Plain bevel siding is lapped (hence the term lap-board) so it will shed water. A minimum lap of 1 inch is used for 6-inch widths, while 8- and 10-inch siding should lap about 1-1/2 inches.

Vertical wood siding is also commonly used. It may be plain-surfaced matched boards, pattern-matched boards, or square-edge boards covered at the joint with a batten strip.

Plywood siding is common. Panel sizes are 4 feet wide by 8, 9, and 10 feet long. To eliminate horizontal joints, plywood is installed vertically. Once installed, plywood lapped sidings may look the same as regular bevel siding.

Wood siding should not be fastened directly to concrete masonry walls. Typically, preservative-treated nominal 1 x 3 wood furring strips are fastened at 16 or 24 inches on center perpendicular to the direction of the wood siding. The wood siding is then fastened to the furring strips with zinc-coated steel, aluminum, or other noncorrosive nails. Plain steel-wire nails with large heads are not recommended because they produce unsightly rust spots on most paints and stains.

## ALUMINUM SIDING

Aluminum siding is factory finished with baked-on enamel and, in appearance, closely resembles painted wood siding. A variety of horizontal and vertical panel styles in both smooth and textured designs are produced with varying shadow lines and size of face exposed to the weather. Panels are fabricated with prepunched nail and vent holes and a special interlocking design.

Aluminum siding is attached to concrete masonry walls in a manner similar to wood siding; refer to Figure 4-8. Typically, preservative-treated furring strips are fastened at 16 or 24 inches on center perpendicular to the direction of the aluminum siding. The aluminum siding is then fastened to the furring strips with zinc-coated steel, aluminum, or other noncorrosive nails; however, the siding should not be fastened tightly to the furring strips to allow for expansion and contraction. Each aluminum strip or piece hooks into the course below and is secured in place by nailing along the slotted top edge. Panels are designed with moisture-proof interlocking joints. A special corner piece covers the ends and allows for expansion and contraction resulting from temperature changes.

Aluminum siding is usually installed with a backer board or insulation board behind each panel. The insulation board adds rigidity and strength as well as insulating value to the aluminum. Many manufacturers produce siding products that include special designs or patented devices to

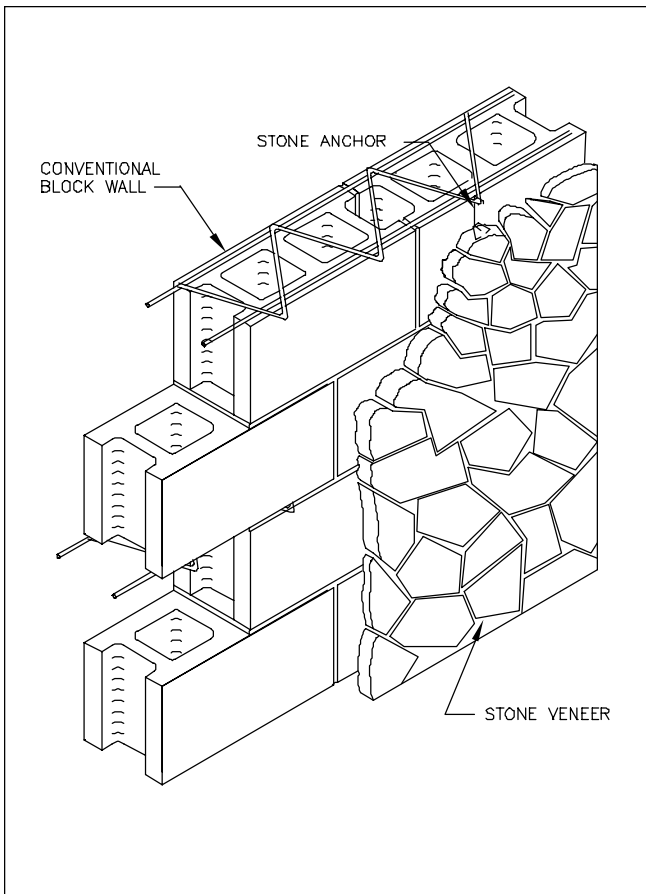

Figure 4-6: Stone Veneer

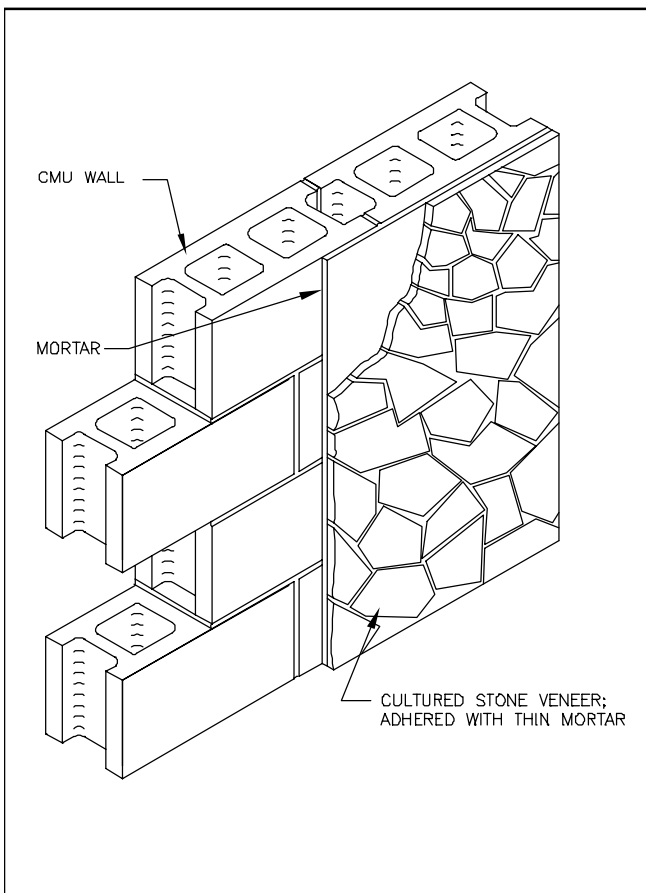

Figure 4-7: Cultured Stone Veneer

simplify installation. Figure 4-8 illustrates the attachment of aluminum siding to a concrete masonry wall.

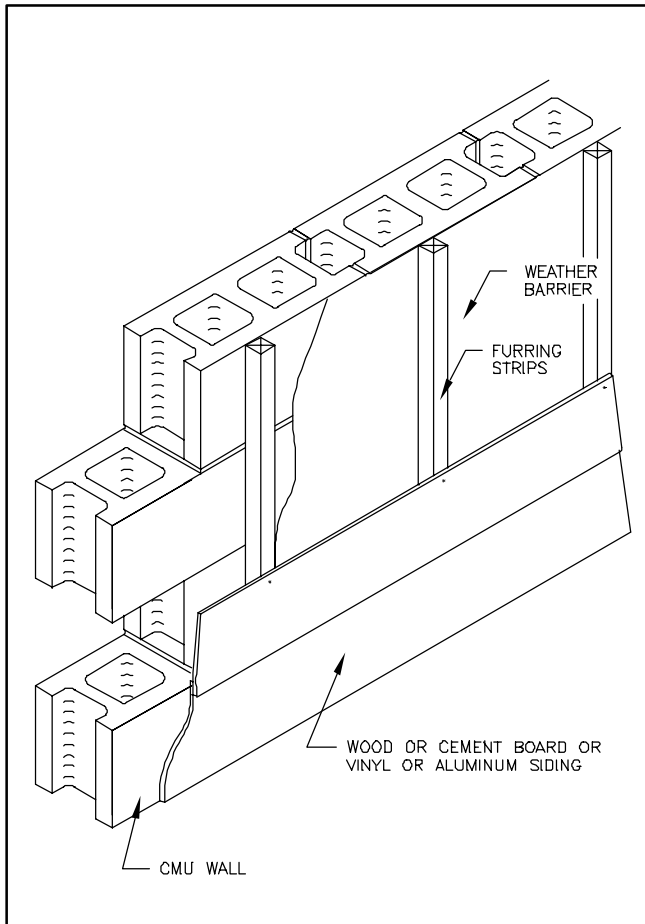

Figure 4-8: Wood, Aluminum, Vinyl, or Fiber-Cement Siding

## VINYL SIDING

Vinyl siding is fabricated of a rigid polyvinyl chloride compound that is tough and durable. It is extruded into vertical and horizontal siding and accessories. It resembles painted wood siding.

A variety of horizontal and vertical panel styles in both smooth and textured designs are produced with varying shadow lines and size of face exposed to the weather. Panels are fabricated with prepunched nail and vent holes and a special interlocking design.

Vinyl siding is attached to a concrete masonry wall in a manner similar to wood or aluminum siding; refer to Figure 4-8. Typically, preservative-treated furring strips are fastened at 16 or 24 inches on center perpendicular to the direction of the vinyl siding. The vinyl siding is then fastened to the furring strips with zinc-coated steel, aluminum, or other noncorrosive nails; however, the siding should not be fastened tightly to the furring strips to allow for expansion and contraction. Each vinyl strip or piece hooks into the course below and is secured in place by nailing along the slotted top edge. Panels are designed with moisture-proof interlocking joints. A special corner piece covers the ends and allows for expansion and contraction resulting from temperature changes.

Vinyl siding is usually installed with a backer board or insulation board behind each panel. The insulation board

adds rigidity and strength as well as insulating value to the vinyl.

Many manufacturers produce siding products that include special designs or patented devices to simplify installation.

## FIBER-CEMENT SIDING

Fiber-cement siding is fabricated of Portland cement, sand, cellulose fiber, and water; some manufacturers may add other materials. Fiber-cement siding closely resembles painted wood siding and is available factory primed from some manufacturers.

A variety of horizontal and vertical panel styles in both smooth and textured designs are produced with varying shadow lines and size of face exposed to the weather. Fiber-cement siding may be lapped or installed vertically with battens. It is typically 5/16 inch thick. Panels are available in 4 feet by 8, 9, or 10 feet.

Fiber-cement siding is attached to a concrete masonry wall in a manner similar to wood siding; refer to Figure 4-8. Typically, preservative-treated furring strips are fastened a maximum of 24 inches on center perpendicular to the direction of the fiber-cement siding. The fiber-cement siding is then fastened to the furring strips with zinc-coated steel, aluminum, or other noncorrosive nails.

Fiber-cement siding does not require a backer board or insulation board behind each panel for added rigidity; however, a backer board may be installed for thermal value.

## STUCCO

Stucco is a finish composed mainly of Portland cement, sand, water, lime, and/or acrylic. Figure 4-9 illustrates the application of stucco to the exterior of a concrete masonry wall.

The three categories of stucco are as follows:

- ✓ Portland cement stucco;
- ✓ polymer-modified stucco; and
- ✓ polymer-based stucco.

Portland cement stucco (PC) is sometimes referred to as traditional stucco and contains no acrylic. Polymer-modified stucco (PM) is sometimes referred to as hard-coat stucco and contains a minimal amount of acrylic. Polymer-based stucco (PB) is sometimes referred to as soft-coat stucco and contains approximately 50 percent acrylic. Acrylic gives stucco some flexibility and water resistance; therefore, stuccoes containing acrylic are more popular in areas subject to severe freeze-thaw cycles.

Stucco is applied to a concrete masonry wall in two or three layers or coats. The first coat is termed the scratch coat and is approximately 1/4 to 3/8 inch thick. The second coat of a three-coat system is termed the brown coat and is approximately 3/8 to 1/2 inch thick. The third coat of a three-coat system or the second coat of a two-coat system is termed the finish coat and is approximately 1/4 inch thick. The finish coat may be tinted by adding color, or the surface may be painted with a suitable material.

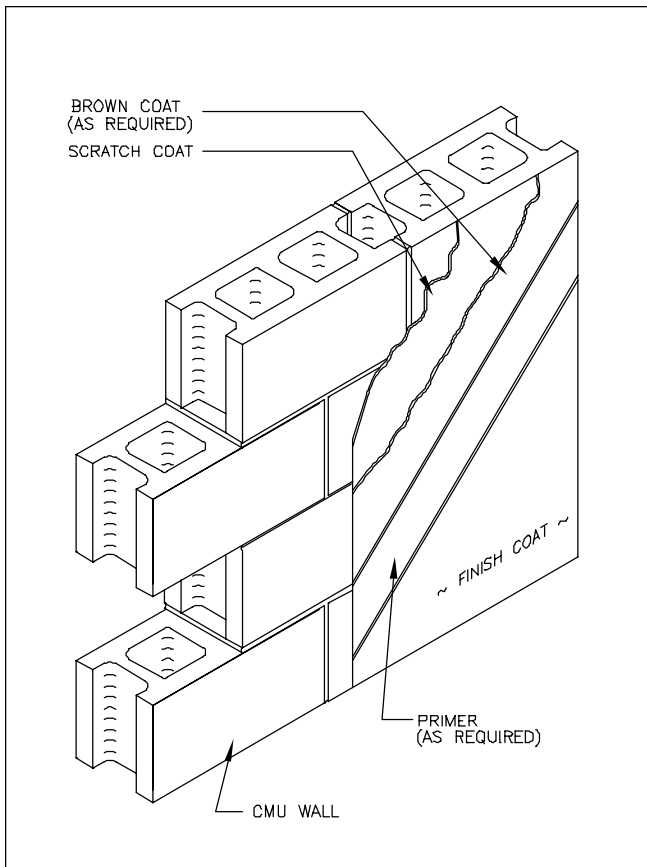

Figure 4-9: Stucco

Stucco on concrete masonry does not require a metal lath base as in its application to light-frame homes because the concrete masonry often provides a porous, textured solid surface to which the stucco attaches. Concrete masonry that does not provide a good bond for stucco needs to be treated with a bonding agent (i.e., primer) before application of the stucco. Molding (i.e., corner bead) with a groove that “keys” the stucco is applied at edges and around openings. Fasteners required to fasten accessories to the concrete masonry wall should be of noncorrosive material.

### DECORATIVE MASONRY FINISH

Many homes in Florida are finished with a 3/8-inch-thick masonry decorative finish. Although the material is identical to stucco as described in the previous section, it is thinner than conventional Portland Cement stucco. Such a finish system is termed a “decorative masonry finish” and is installed primarily to provide a smooth weather-resistant finish over a concrete masonry wall and hide mortar joints.

### EXTERIOR INSULATED FINISH SYSTEM

Synthetic stucco is commonly referred to as an Exterior Insulated Finish System (EIFS). EIFS is a finish system that is installed with a maximum 4-inch-thick rigid foam insulation board adhered to a concrete masonry wall as the base. Fiberglass mesh is then installed on the insulation board and covered with two coats—a cement-based base coat and an acrylic-modified synthetic finish coat in the desired color. The finish coat is troweled, sprayed, or rolled on.

EIFS is available as either a drainable system or a system without drainage. Figures 4-10 and 4-11 illustrate drainable and undrainable EIFS, respectively. Drainable systems have an additional material layer between the insulation and the concrete masonry wall to allow water to flow behind the finish system into weep holes below. Some drainable systems use patented rigid insulation with drain channels molded onto the back face of the insulation. The channels eliminate the need for installing separate drain material. At the top of openings, bottom of walls, etc., weep holes are created to allow any accumulated water to exit the wall.

Fasteners required to fasten the insulation, molding, and other accessories to the concrete masonry wall are typically required to be galvanized or of another noncorrosive material.

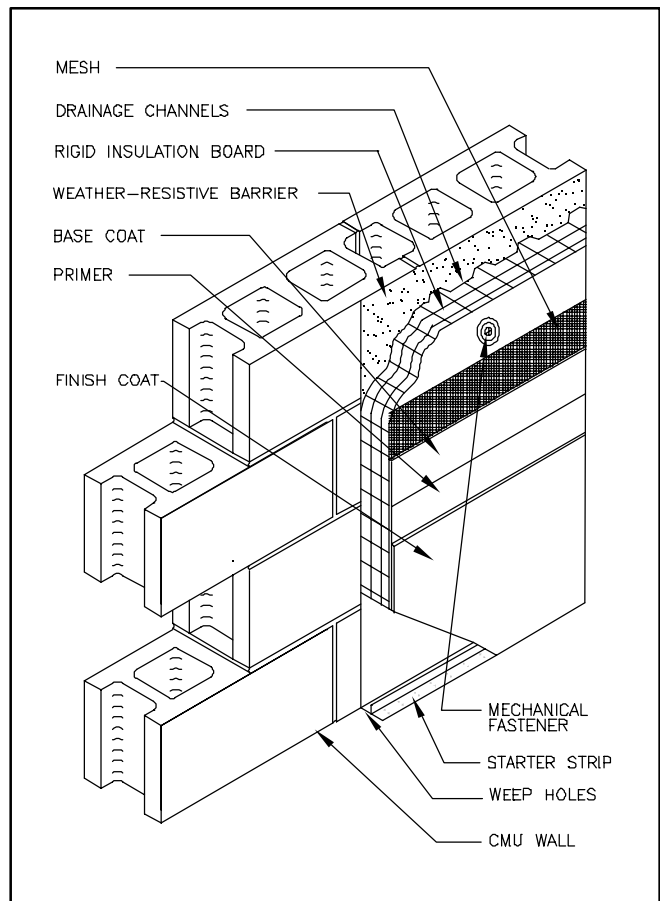

Figure 4-10: EIFS (Drainable)

### INTERIOR FINISHES

Exposed brick or block, stone veneer, wood or concrete paneling, and stucco as described in earlier sections for exterior finishes may also be used for interior residential finishes; therefore, they are not discussed here. Other finishes, however, used for the interior but not commonly used for residential exterior applications include gypsum board (i.e., drywall), plaster, and wallpaper. Refer to Figures 4-12, 4-13, and 4-14 for the typical installation of these systems on a concrete masonry wall.

Gypsum board may be adhered to above-grade concrete masonry walls with construction adhesive. Bracing is

typically required to hold the gypsum board in place until the adhesive sets. Where moisture on the interior surface of the concrete masonry wall may occur (i.e., below-grade walls), gypsum board should be installed on preservative-treated furring strips 16 or 24 inches on center to provide a minimum 1/2-inch air space between the wall and the gypsum board.

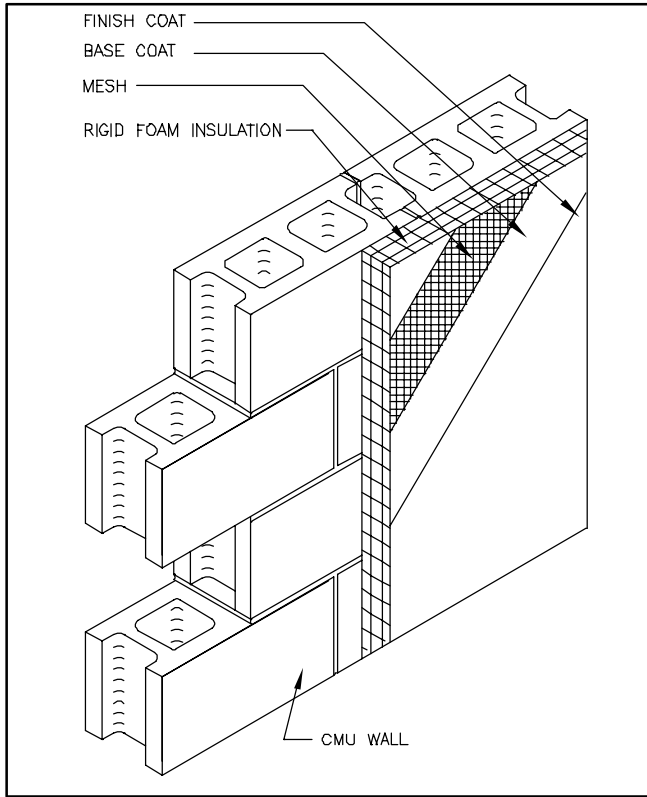

Figure 4-11: EIFS (Nondrainable)

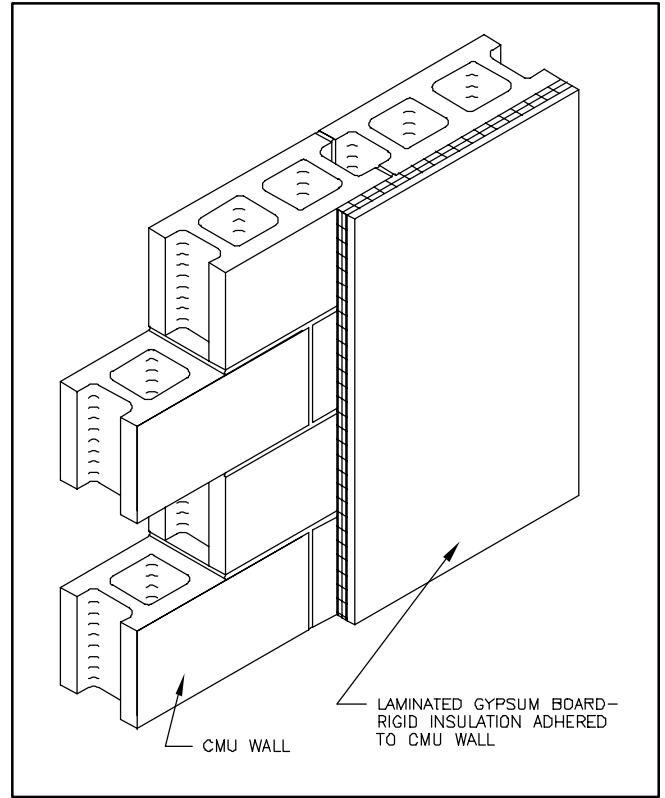

Figure 4-13: In-Sulate by Agile Building Systems, LLC

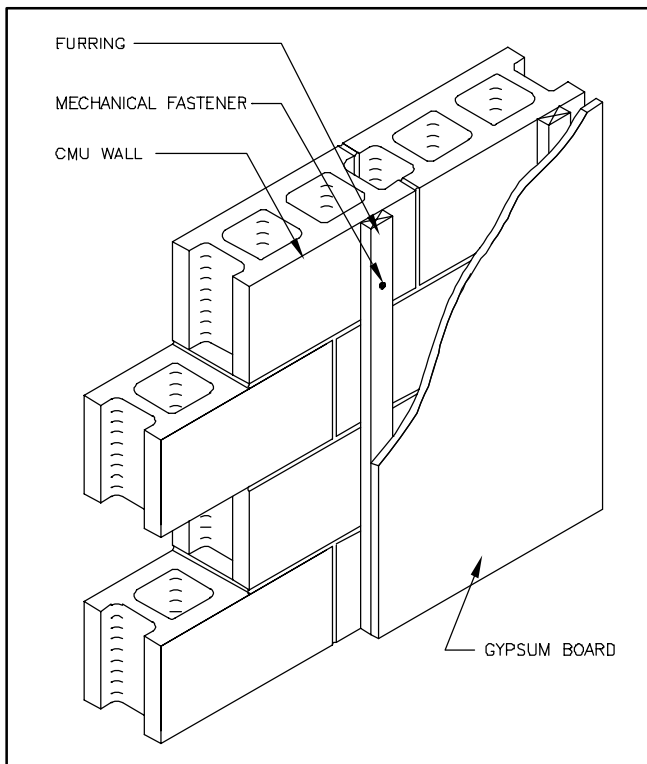

Figure 4-12: Gypsum Board

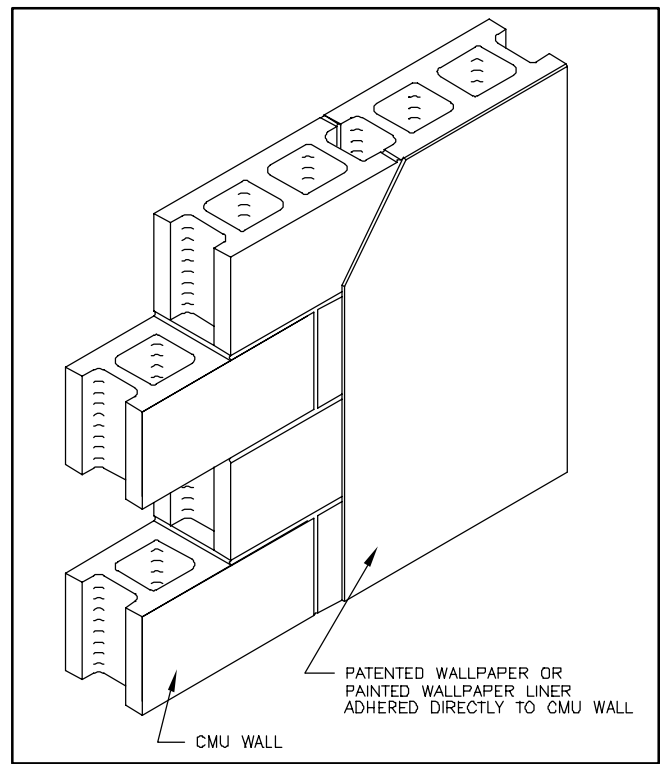

Figure 4-14: Plaster in a Roll™ by Flexi-Wall Systems

Plaster is traditional Portland cement stucco for interior use. It is installed on the interior in the same way that exterior traditional stucco is applied. Refer to the Stucco section for more information about plaster (traditional (PC) stucco) and its proper application on a concrete masonry wall.

Generally, wallpaper cannot be installed directly on concrete masonry; however, some wallpapers (i.e., gypsum-based, fabric-backed wallpaper) are designed specifically for use over concrete masonry, concrete, or other surfaces that have shallow joints, holes, etc. The wallpaper is typically a heavy, jute-type fabric impregnated with gypsum plaster that bridges small cracks and mortar joints. It is installed in a manner similar to traditional wallpaper and is available in a variety of colors. However, instead of drywall paste, a patented adhesive is required. This wallpaper is known as Plaster in a Roll™. Available too is a plaster wall liner known as Faster Plaster™. The wall liner is similar to heavy, jute-type fabric impregnated with gypsum plaster and is installed like wallpaper; however, it provides a fine-textured plaster finish on which paint or regular wallpaper can then be applied.

## **CONCLUSIONS**

Several finishes and finish systems are available in today's market that can be used with masonry wall construction.

Good and practical construction details are vital to the satisfactory performance of exterior and interior finishes on concrete masonry wall construction. The details herein are generic, but represent good practice. Many finish manufacturers have warranties that become void if installation does not comply exactly with the manufacturers' installation instructions; therefore, the designer or builder is advised to consult the finish manufacturer before installation to determine if the generic details require modification.

## **RESOURCES**

### **Agile Building Systems, LLC**

30 West Third Street, Third Floor  
Williamsport, Pennsylvania 17701

☎ 888.326.5640

🌐 <http://www.freeyellow.com/members5/agilebuilding>

### **Allan Block Corp.**

7400 Metro Boulevard, Suite 185  
Edina, Minnesota 55439

☎ 612.835.5309

🌐 <http://www.allanblock.com>

🌐 <http://www.novabrik.com>

### **Aluminum Association (AA)**

900 19th Street, N.W., Suite 300  
Washington, DC 20006

☎ 202.862.5100

🌐 <http://www.aluminum.org>

### **American Forest and Paper Association (AF&PA)**

1111 19th Street, N.W., Suite 800

Washington, DC 20036

☎ 800.890.7732

🌐 <http://www.afandpa.org>

### **American Hardboard Association (AHA)**

1210 W. Northwest Highway

Palatine, Illinois 60067

☎ 708.934.8800

### **American Plywood Association (APA)**

P.O. Box 11700

Tacoma, Washington 98411-0700

☎ 253.565.6600

🌐 <http://www.apawood.org>

### **Association of the Wall and Ceiling Industries (AWCI)**

803 West Broad Street, Suite 600

Falls Church, Virginia 22046

☎ 703.534.8300

🌐 <http://www.awci.org>

### **Brick Institute of America (BIA)**

11490 Commerce Park Drive, Suite 300

Reston, Virginia 22091

☎ 703.620.0010

🌐 <http://www.brickinst.org>

### **Building Stone Institute (BSI)**

85 Yerkes Road

Purdys, New York 10578

☎ 914.232.5725

### **Cast Stone Institute (CSI)**

10 W. Kimball Street

Winder, Georgia 30680

☎ 770.868.5909

🌐 <http://www.caststone.org>

### **Flexi-Wall Systems**

208 Carolina Drive

P.O. Box 89

Liberty, South Carolina 29657-0089

☎ 800.843.5394

### **Gypsum Association (GA)**

81 First Street, N.E., Suite 510

Washington, DC 20002

☎ 202.289.5440

🌐 <http://www.gypsum.org>

### **NAHB Research Center, Inc.**

400 Prince George's Boulevard

Upper Marlboro, Maryland 20774-8731

☎ 800.638.8556

🌐 <http://www.nahbrc.org>

### **National Concrete Masonry Association (NCMA)**

2302 Horse Pen Road

Herndon, Virginia 20171-3499

☎ 703.713.1900

🌐 <http://www.ncma.org>

**National Paint and Coatings Association (NPCA)**

1500 Rhode Island Avenue, N.W.

Washington, DC 20005-5503

☎ 202.462.6272

🌐 <http://www.paint.org>

**National Stone Association (NSA)**

1415 Elliott Place, N.W.

Washington, DC 20007

☎ 202.342.1100

🌐 <http://www.aggregates.org>

**Portland Cement Association (PCA)**

5420 Old Orchard Road

Skokie, Illinois 60077-1083

☎ 847.966.6200

🌐 <http://www.portcement.org>

**U.S. Department of Housing and  
Urban Development (HUD)**

451 Seventh Street, S.W., Suite 8132

Washington, DC 20410

☎ 202.708.4370

🌐 <http://www.hud.gov>

*Publications*

☎ 800.245.2691

🌐 <http://www.huduser.org>

**Vinyl Siding Institute (VSI)**

1801 K Street, N.W., Suite 600K

Washington, DC 20006

☎ 202.974.5200

🌐 <http://www.vinylsiding.org>



*Concrete Shapes and Sizes Manual.* National Concrete Masonry Association (NCMA), Herndon, Virginia, 1997.



*Concrete Masonry Handbook, fifth edition.* Portland Cement Association (PCA), Skokie, Illinois, 1991.





# Insulation Placement

FS • 5

An information series on residential concrete masonry technology

## SUMMARY

Several types of insulation systems as well as insulation materials are available for use in residential concrete masonry construction; however, some home builders may be unfamiliar with the appropriate installation techniques. This fact sheet discusses basic types of insulation, thermal properties, and general installation guidelines; refer to Fact Sheet 7 (FS•7) for more information on specific fasteners and tools.

Insulation types are discussed in terms of method of installation. A concrete masonry wall system may be insulated by

- ✓ inserting insulation into the concrete masonry unit core;
- ✓ applying insulation to the surface of the concrete masonry unit; or
- ✓ manufacturing concrete masonry units that have inherent insulating properties.

*The details shown herein are generic in nature. The designer or builder is advised to consult the insulation or specialty block manufacturer before installation to determine specific installation requirements.*

## R-VALUE VERSUS THERMAL MASS

Recent years have seen greater emphasis on the thermal performance of a home in terms of the complete home “envelope”, taking into account thermal resistance, thermal mass, and air infiltration.

Thermal resistance, commonly referred to as R-value, is a standard measure of the thermal performance of a material or system. The R-value describes the steady state resistance to heat flow through a building component. While thermal resistance is an effective and popular tool for comparing component performance, it is not the only factor in determining whether the whole-house system is energy-efficient.

The role of thermal mass in energy efficiency is less clear and difficult to calculate and quantify. Thermal mass materials have the ability to absorb and store heat, slowly releasing the heat over an extended period. In addition, thermal mass materials absorb and release heat at a slower rate than low-mass materials, a feature that may be used to keep a room at a more constant temperature. Materials such as concrete have a high thermal mass; therefore, thermal mass influences heating, ventilating, and air conditioning (HVAC) design in a concrete masonry home much more so

than in light-frame construction. The higher the thermal mass of a material, the better its ability to keep interior temperatures constant as exterior temperatures vary throughout the day. For example, in the Southwest, the sun heats the exterior of a concrete masonry wall to temperatures over 100 degrees F during the course of a day. Due to the concrete masonry unit’s high thermal mass, the heat given does not penetrate to the other side of the wall until 2 to 4 hours later (i.e., late afternoon or early evening) for hollow concrete masonry walls or 6 to 8 hours later for solid grouted concrete masonry walls. By that time, outside temperatures tend to drop significantly and heat may be provided by the thermal mass effect. If the structure is located in an area in which exterior temperatures do not vary widely, thermal mass has less impact on energy savings.

Monolithic installation of masonry can help decrease air leakage through the wall system provided penetrations through the wall are sealed. Thermal mass and reduced infiltration, do not, however, provide sufficient resistance to heat flow. In many climates in the United States, insulation must be installed. Refer to Table 1 for a comparison of R-values for common insulating materials and concrete masonry units. The following sections discuss many different insulation materials.

Table 5-1: Typical R-Values

Insulating Material	Representative R-Value (per inch of thickness)
Fiberglass batt	3
Polyisocyanurate	7
Polystyrene--expanded	4
Polystyrene--extruded	5
Polyurethane	8
Perlite	3
Vermiculite	2
Foamed-in-place	5
Material	Representative R-Value
Radiant insulation	4.5
Concrete Masonry Unit	Representative R-Value (total)
<i>Normal-Weight</i>	
4-inch-thick	0.8
8-inch-thick	1
12-inch-thick	1.2
<i>Light-Weight</i>	
4-inch-thick	1.5
8-inch-thick	2
12-inch-thick	2.5

## CORE INSULATION

Core insulation refers to insulation placed into the inner cores of a concrete masonry unit. A variety of insulation materials may be used for this purpose. When core insulation is used in traditionally shaped concrete masonry units the concrete masonry webs of the unit remain uninsulated, preventing the overall wall system's R-value from reaching values as high as those associated with some other insulation placement techniques described herein. Inserting insulation into the cores of the unit, however, may reduce the time needed to install an insulated concrete masonry unit (CMU) wall and allows the CMU to remain exposed on both faces for aesthetic reasons if desired.

If the surfaces of the concrete masonry wall are not desired to be exposed, surface-applied insulation described in the following sections may further enhance the R-value.

Three types of insulation may be used to fill the concrete block core as follows:

- ✓ poured-in-place;
- ✓ foamed-in-place; and
- ✓ standard molded inserts.

### Poured-in-Place Insulation

Poured-in-place insulation typically consists of vermiculite or perlite either poured in upon completion of an unreinforced wall or poured in stages in a horizontally reinforced wall. Poured-in-place insulation provides increased thermal resistance, although it may settle over time; as a result, the top of the wall or core may eventually have little to no insulation. Poured-in-place materials vary in their ability to retard fire and moisture; consult the manufacturer to ensure that the product selected meets local code requirements.

### Foamed-in-Place Insulation

Foams may also be installed in the core in a manner similar to poured-in-place insulation. Most foams consist of two separate chemicals that, when mixed, react to each other and create the foam. A foam applicator is available to mix the two chemicals during application, simplifying installation.

Numerous chemicals are currently on the market. In the past, some foams contained formaldehyde; many jurisdictions have subsequently banned them. It is important to determine the content of the foam under consideration and verify compliance with local codes.

### Molded Insulation Inserts

Molded insulation typically consists of a molded expanded polystyrene (EPS) insert that is wedged into the core of a concrete masonry unit; refer to Figure 5-1 for an illustration of one such unit currently available.

Some molded insulation core inserts are fitted in the field; however, most inserts are already inserted into the concrete masonry unit's core at the factory. Preinsulated concrete masonry unit cores eliminate the need for an additional crew in the field, simplifying the installation of the masonry unit and reducing labor costs. Preinsulated

concrete units typically, however, have higher material costs.

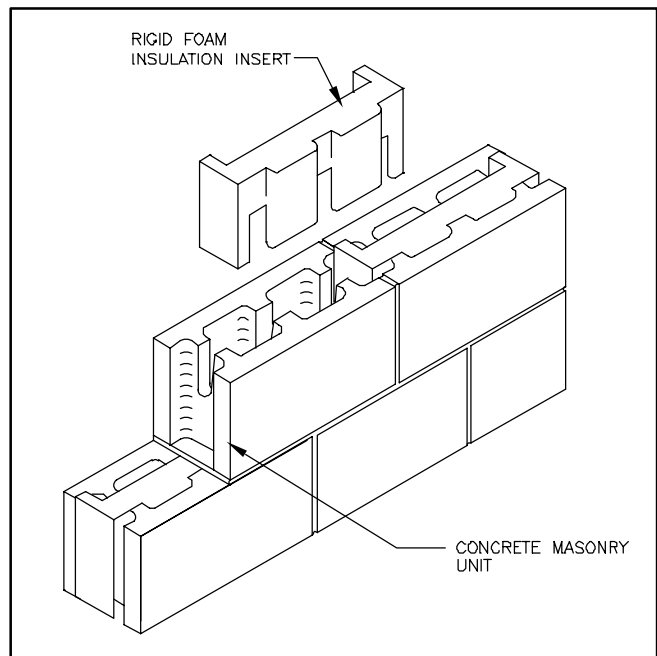

Figure 5-1: Molded Insert Core Insulation

## SURFACE INSULATION FOR SINGLE-WYTHE CONSTRUCTION

Several insulation systems may be installed to the concrete masonry wall's surface upon completion of the masonry wall.

Applying rigid insulation to the interior or exterior face of a single-wythe concrete masonry wall is common. Surface insulation is particularly labor-intensive in that it requires additional steps during construction; however, by covering the entire wall surface of one or both faces of the concrete masonry wall, surface insulation increases the R-value of the concrete masonry wall more than core insulation.

### Insulation Types

Three insulation materials are used for this application as follows:

- ✓ polystyrene;
- ✓ polyurethane; and
- ✓ polyisocyanurate.

Polystyrene comes in two basic categories: expanded bead and extruded. Expanded bead is made by superheating pellets of styrene until they expand to form a foam insulation that is both light and inexpensive. Extruded polystyrene is the same chemical product as expanded polystyrene, but is extruded and does not possess beads or visible voids. Extruded polystyrene is more expensive than expanded polystyrene; however, the material has a higher R-value per inch of thickness. Refer to Table 5-1 for respective R-value ranges.

Polyurethane and polyisocyanurate foam insulations are similar. Both are closed-cell foams that contain a low-conductivity gas in the cells. The high thermal resistance of

the gas contributes to the foams' high R-values; refer to Table 5-1 for R-values. Polyisocyanurate is more fire-resistant and has a slightly higher R-value than polyurethane foams, but both have a propensity to absorb moisture, which limits their use in moist exterior applications, particularly below grade.

Radiant "insulation" is also available and serves as both a reflective insulation and vapor retarder. It is comprised of a very thin sheet of paper-backed aluminum foil laminated to expanders that separate the paper from the foil creating a reflective air space. It is designed for use in interior applications. The R-value of the system is dependent on the depth of the air space formed. Refer to the Resources section for manufacturers' information.

### Exterior Surface Application

Regardless of type, foam insulations are applied in a similar manner; refer to Figure 5-2.

A below-grade concrete masonry wall must be dampproofed before installation of insulation board. The insulation board may be secured to the foundation wall by using either chemical adhesives or mastic. Adhesives or mastics produce few, if any, breaks in the thermal barrier. Another alternative for fastening insulation is to use a masonry screw with a large washer. Another technique uses screws with plastic anchors to retard thermal bridging.

For exterior above-grade applications, the insulation is attached to a concrete masonry wall in much the same way as in below-grade applications. Although dampproofing is not required, a weather-resistant barrier (i.e., finish system) is required to protect the insulation from water damage, sunlight, insects, and physical damage.

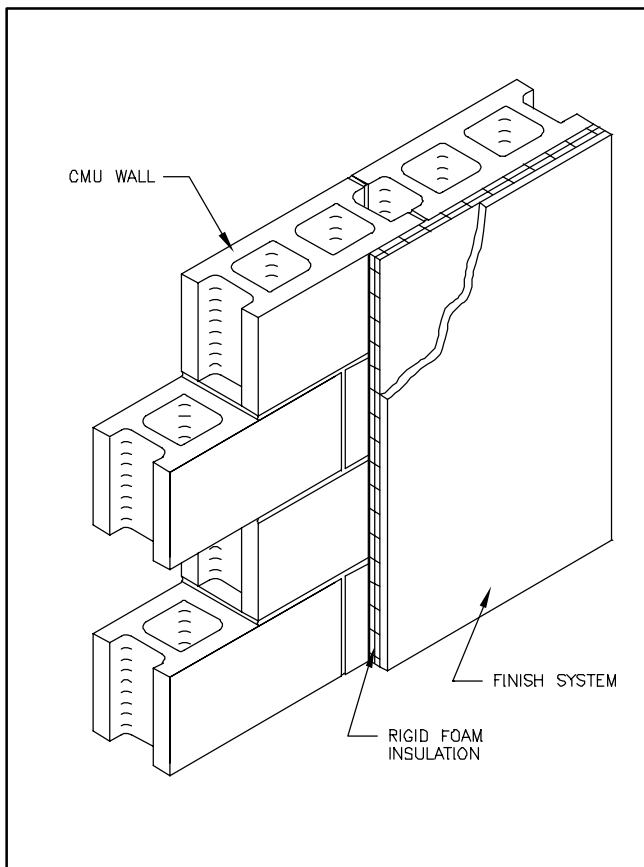

Figure 5-2: Exterior Surface Insulation

### Interior Surface Application

Installing insulation to the interior of a concrete masonry wall prevents exposure to the elements (i.e., wind, rain, etc.). However, insulation installed on the interior face of the wall presents some challenges with respect to interior finish attachment and utility placement; refer to Fact Sheets 4 and 6 (FS•4 and FS•6), respectively. Refer to Figure 5-3 for illustrations regarding insulation installation alternatives.

The most common interior finish in residential construction is gypsum board, also known as drywall. Some builders install drywall directly to the insulation by using construction adhesives or manufactured composite drywall-insulation boards; refer to Fact Sheet 4 (FS•4). In some cases, the rigid insulation board contains a metal furring strip that acts as a "stud" to which the gypsum board is attached. Another alternative is to attach metal, wood, or plastic furring strips or channels directly to the masonry with typical masonry connectors such as cut nails, helically threaded concrete nails, or powder-actuated masonry fasteners. The rigid insulation is then installed between the furring strips.

While the resulting R-value for the gypsum board-insulated wall is good, it is not as high as in exterior surface applications. Installation of the insulation between furring strips leaves small wall areas uninsulated just as in light-frame stud construction.

One insulation manufacturer has altered its insulation product so that when used with z-channels the entire wall surface is insulated, providing a continuous thermal break. The system is known as Hatton Batten Tuff-R®. In this particular system, the z-channel depth is less than that of the insulation thickness. The insulation has grooved ends allowing it to insert into and over the z-channel-furring strip. With the insulation spanning the entire wall area, the system results in a higher R-value than if traditional insulation board and full-depth z-channel or traditional furring strips were used.

If local climate conditions are severe and the required R-value cannot be met by using one of the previously mentioned insulation methods, a 2x-stud wall on the interior of the home may be constructed. The stud wall is then insulated in a manner similar to the furring strip system described earlier. If a stud wall is constructed, fiberglass batt insulation may be used to insulate the wall, just as in light-frame construction.

Radiant insulation may be used in lieu of, or in addition to, rigid insulation board and is typically installed over the furring strips. One manufacturer's product, known as Vapor Shield, is available in rolls. The R-value is based on the size of the air space created by the furring strip. The walls are "wrapped" with the Vapor Shield and stapled to the furring strips before installing the interior finish. Refer to the Resources section for the manufacturer's contact information.

### INSULATION FOR MULTIPLYTHE CONSTRUCTION

Though not used often in residential construction because of cost and complexity of construction, the multiplythe wall system has been in use for many years and is

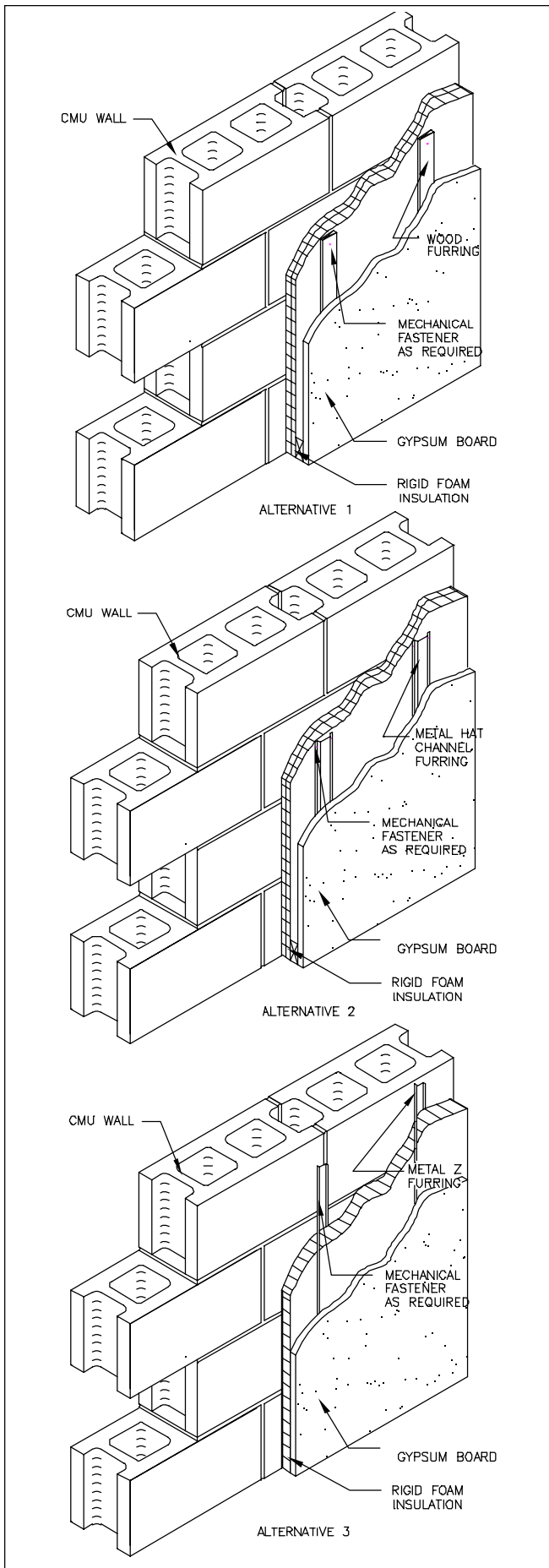

Figure 5-3: Interior Surface Insulation

still used in commercial construction. It is included herein because it may be used with a brick exterior finish for residential construction.

Multiwythe cavity wall construction consists of two walls (wythes) built parallel to each other with a minimum of 2 inches between the wythes. Both wythes may be concrete masonry; however, in residential construction, it is more typical for one wythe to be constructed of brick and the other wythe (backup wythe) of concrete masonry. Multiwythe construction increases sound attenuation, fire resistance, and moisture resistance.

The air space between the two wythes, if present, is an excellent location for rigid board insulation as well as for poured-in-place insulation; refer to Figure 5-4. The distance between the two wythes can vary up to a maximum of 4-1/2 inches, thus facilitating multiple sheets of insulation. It is possible to construct a wall in this manner with an R-value of 25 to 30. However, it is critical to ensure that a clearly defined air gap (1 inch minimum) exists between the insulation and the exterior wythe.

*Consult an engineer before increasing the cavity between wall wythes more than 4-1/2 inches to ensure that the wall is structurally adequate.*

### Composite Wall Insulation

Composite concrete masonry unit construction is similar to cavity wall construction; however, no air space exists between the two wythes. Insulation usually takes the form of either concrete masonry unit core insulation or surface-applied insulation. A system available on today's market delivers rigid insulation to the job site already adhered and inserted between a concrete masonry wythe unit and an exterior wythe unit. The exterior wythe may be a variety of materials such as faux stone, brick veneer, etc., refer to Figure 5-5.

The wall system arrives in a single piece and thus is installed in a manner similar to a conventional concrete masonry unit, with mortar joints between the units. The mortar joints are not insulated; therefore, the R-values, though higher than in conventional concrete masonry, are not as high as that of walls entirely covered by insulation. Studies are underway to determine alternative installation methods to increase the R-value of this system. The R-value range for the system is approximately R-8 and depends on the size of the mortar joint.

### INSULATING CONCRETE MASONRY UNIT

Insulating concrete masonry units combine concrete and insulation materials into one unit by modifying the properties of the concrete itself during the block manufacturing process. Refer to the manufacturer for detailed installation guidelines as well as for material information. Many products are proprietary.

One type of insulating concrete masonry unit is manufactured by using a lightweight aggregate with synthetic and mineral content. The units depend on polystyrene for their insulating value, but sacrifices some strength. The units may be installed in a manner similar to a normal-weight concrete masonry unit or with a mortarless system. This unit is available from Sparfil International, Inc.

Refer to the Resources section for manufacturer's contact information.

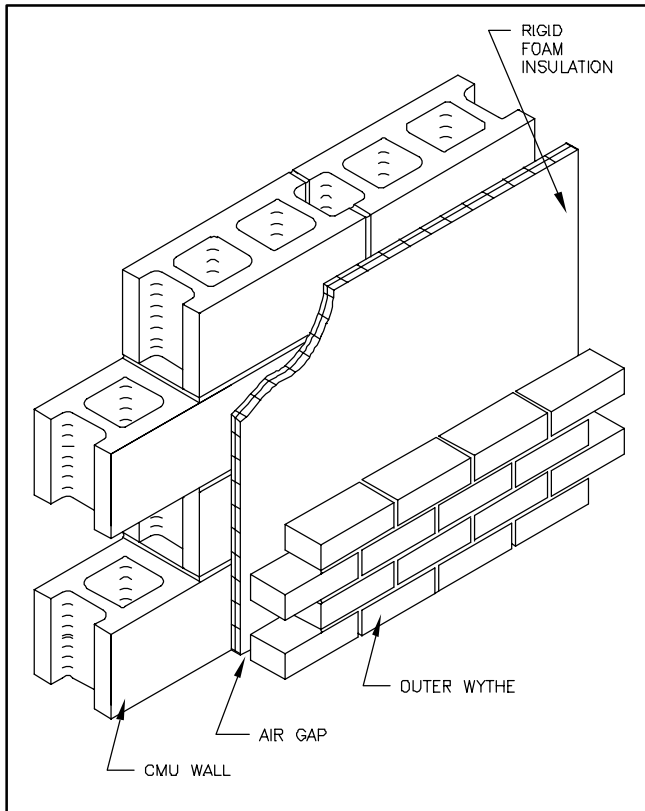

Figure 5-4: Multiwythe Wall Insulation

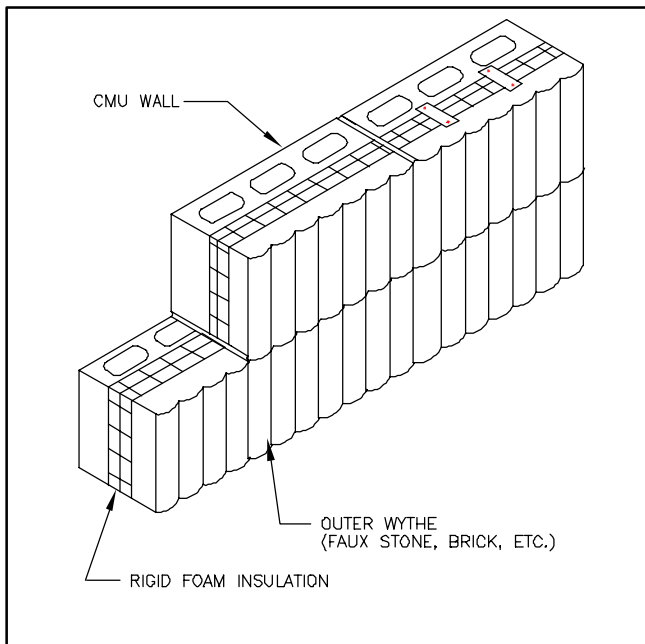

Figure 5-5: Patented Composite Wall Insulation

## CONCLUSIONS

Several conventional and innovative techniques and systems are available to increase the energy efficiency of a concrete masonry home. Each technique or system has advantages and disadvantages based on the given application and budget. In addition, there are many

variations on the methods discussed herein. It is the responsibility of the designer and builder to determine which method satisfies local code requirements, while still addressing budget constraints, labor availability, and client desires.

## RESOURCES

### Hatton Batten Tuff-R<sup>®</sup>

P.O. Box 31602  
Tampa, Florida 33631  
☎ 800.celotex  
🌐 <http://www.celotex.com>

### NAHB Research Center, Inc.

400 Prince George's Boulevard  
Upper Marlboro, Maryland 20774-8731  
☎ 800.638.8556  
🌐 <http://www.nahbrc.org>

### National Concrete Masonry Association (NCMA)

2302 Horse Pen Road  
Herndon, Virginia 20171-3499  
☎ 703.713.1900  
🌐 <http://www.ncma.org>

### North American Insulation Manufacturers Association

44 Canal Center Plaza, Suite 310  
Alexandria, Virginia 22314  
☎ 703.684.0084  
🌐 <http://www.naima.org>

### Portland Cement Association

5420 Old Orchard Road  
Skokie, Illinois 60077-1083  
☎ 847.966.6200  
🌐 <http://www.portcement.org>

### Sparfil International, Inc.

P.O. Box 270336  
Tampa, Florida 33688  
☎ 813.963.3794  
🌐 <http://home1.gte.net/sunblock>

### U.S. Department of Housing and Urban Development (HUD)

451 Seventh Street S.W., Suite 8132  
Washington, DC 20410  
☎ 202.708.4370  
🌐 <http://www.hud.gov>  
*Publications*  
☎ 800.245.2691  
🌐 <http://www.huduser.org>

### VaporShield

612 Bridgers Avenue West  
Auburndale, Florida 33823  
☎ 800.448.3401  
🌐 <http://www.fifoil.com>



# Utility Placement

FS • 6

*An information series on residential concrete masonry technology*

## **SUMMARY**

The placement of utilities presents some unique considerations to designers and builders unfamiliar with concrete masonry wall construction. Three main factors affect utility placement in concrete masonry walls. They are

- ✓ the type of CMU wall construction (i.e., hollow, solid, grouted, or partially grouted);
- ✓ insulation (if present); and
- ✓ interior finish selection.

These factors are discussed herein as they affect utility installations. Refer to Fact Sheet 7 (FS•7) for more information on specific fasteners and tools.

*The illustrations contained herein are “generic” and “typical” for many areas in the United States. However, certain areas of the country may impose more stringent requirements concerning utility installation. The designer or builder is advised to consult the local building code to determine if additional requirements exist beyond those discussed herein.*

## **ELECTRICAL INSTALLATION**

Electrical wiring and components may be installed within a concrete masonry wall or on the interior face of a concrete masonry wall.

### ***Within CMU Wall***

Although some builders install electrical wiring within concrete masonry walls, they are advised against doing so except in one-story construction for a variety of reasons, including the presence and placement of grouted or solid concrete masonry units, increased labor, and reduced thermal resistance in core-insulated walls.

Installing electrical lines within a concrete masonry wall may be most practical for one-story construction in a hollow concrete masonry home. Holes are punched in the wall for electrical boxes and the electrical wiring is run within conduit through the vertical core of hollow concrete masonry units to the top of the wall. The horizontal runs of electrical wiring are then installed in the attic space of the home. Conduit within the wall may be installed during or after wall construction. Either method increases the number of labor hours needed to install the electrical utility.

If the concrete masonry wall contains core insulation, electrical wiring placed either before or after the insulation requires more labor and coordination at the job site. In

addition, a reduction in thermal resistance may occur if quality control at the job site is not adequate.

The horizontal runs of wiring may be placed in the wall if modified concrete masonry units are used in lieu of standard concrete masonry. These modified concrete masonry units, available from some manufacturers, have a cutout in the webs of the concrete block to allow for conduit insertion without requiring masonry field cutting.

Installing electrical wiring within a concrete masonry wall presents difficulties particularly in partially grouted or solid concrete masonry walls owing to the horizontal bond beams present at the top of each wall story as illustrated in Fact Sheets 1 through 3 (FS•1 through FS•3). Bond beams hinder vertical runs of electrical wiring. In addition, some vertical cores in a concrete masonry wall may be grouted solid to resist structural loads, limiting horizontal runs of electrical wiring. For labor efficiency and structural reasons, cutting or boring through solid or grouted beams and columns is not recommended.

### ***On Interior Face of CMU Wall***

For most residential homes built in the United States, installing electrical wiring and components on the interior face of concrete masonry walls is the preferred method of installation. This approach does not interfere with the wall's construction. It lends itself to easy installation and provides access to wiring and components.

Electrical wiring and components can be installed on the interior face of any concrete masonry wall whether the concrete masonry walls are hollow, partially or fully grouted, or solid. Electrical installation is typically conducted after the walls are constructed and prepared for interior finishes; therefore, coordination between the electrical contractor and the mason is limited to through-wall utility penetrations. For through-wall utility penetrations, the use of a sleeve is recommended. Typically a rigid plastic pipe, the sleeve is inserted into the wall by the mason during construction. After the wall is constructed, the utility line is simply inserted through the sleeve. While the use of a sleeve requires coordination between the electrical contractor and the mason during wall construction, it promotes ease of utility installation and expedites required maintenance. Refer to Figure 6-1, which illustrates the use of a sleeve for through-wall penetrations. When utility penetrations are below grade, care should be taken to prevent moisture seepage.

Lastly, the installation of electrical wiring and components on the interior face of a concrete masonry wall is faster and less costly than the installation of electrical wiring and components within a concrete masonry wall. Not

only may this approach reduce the number of labor hours required, but it also reduces material cost because conduit is not typically required. However, these costs must be balanced with potential savings when applying interior finishes directly to the masonry walls.



Figure 6-1: Utility Penetration through CMU Wall

The interior finish of a concrete masonry wall determines how electrical wiring and components are installed on the interior face of the wall. The interior finish selections may be grouped into three general categories as follows:

- ✓ interior surface of CMU wall exposed;
- ✓ interior finish installed on furring strips; and
- ✓ interior finish installed on rigid foam insulation.

If the interior face of the concrete masonry wall is left exposed, electrical boxes are mounted on the wall with face plates and the wiring run in conduit or hidden behind decorative molding attached to the wall surface.

Another alternative is to use electrical raceways. Commonly used in commercial buildings, electrical raceways are available for residential applications regardless of the interior finish desired. Electrical raceways are available in white or wood-laminate versions to blend with décor and typically mounted at the base of the wall to resemble traditional baseboards; refer to Figure 6-2.

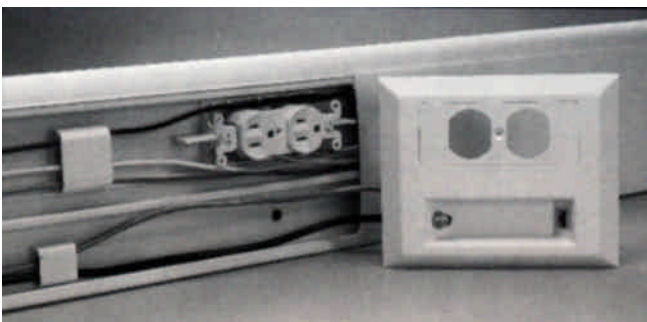

Figure 6-2: Electrical Raceway by the Wiremold Company

If the interior finish is installed on furring strips, as discussed in Fact Sheet 4 (FS•4), electrical boxes may be

mounted on the concrete masonry wall by using shallow electrical boxes as shown in Figure 6-3; or a hole may be created in the wall to allow the use of standard electrical boxes as shown in Figure 6-4. Electrical wiring may be run without conduit through the furring strips and in the cavity between the furring strips. Metal plates are nailed to the furring strip over the notch in the furring strip where the wiring runs. The metal plate protects the wiring and holds it in place as in light-frame construction.



Figure 6-3: Shallow Electrical Box Installation

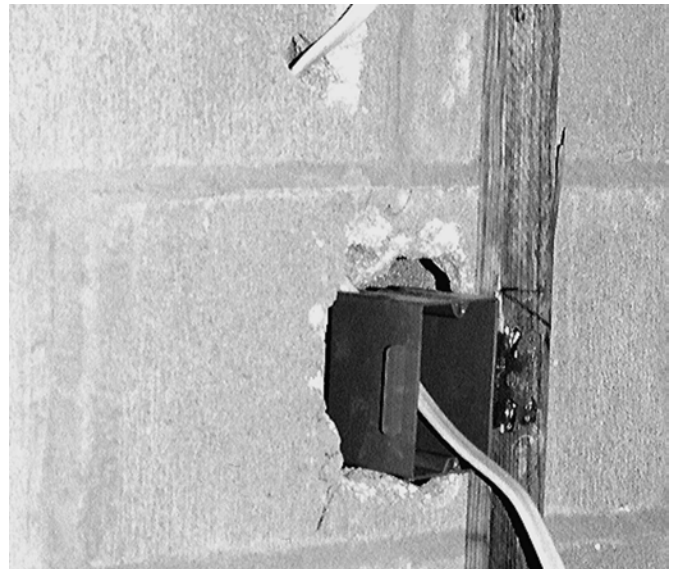

Figure 6-4: Standard Electrical Box Installation

If the interior finish is installed on rigid foam insulation, provisions are required to secure the wiring and components to the foam. Shallow or standard electrical boxes are installed in the same manner as in “furred” walls. If the insulation is particularly thick, the electrical boxes may be installed by cutting or routing out some of the foam



insulation. The electrical boxes are then inserted into the hole in the foam and secured with construction adhesive.

Electrical wiring may be run without conduit through the foam insulation by routing or cutting out channels in the foam. Care must be taken to ensure that the wiring is placed at the code-required depth. Refer to Figure 6-5, which illustrates electrical installation in rigid foam insulation.

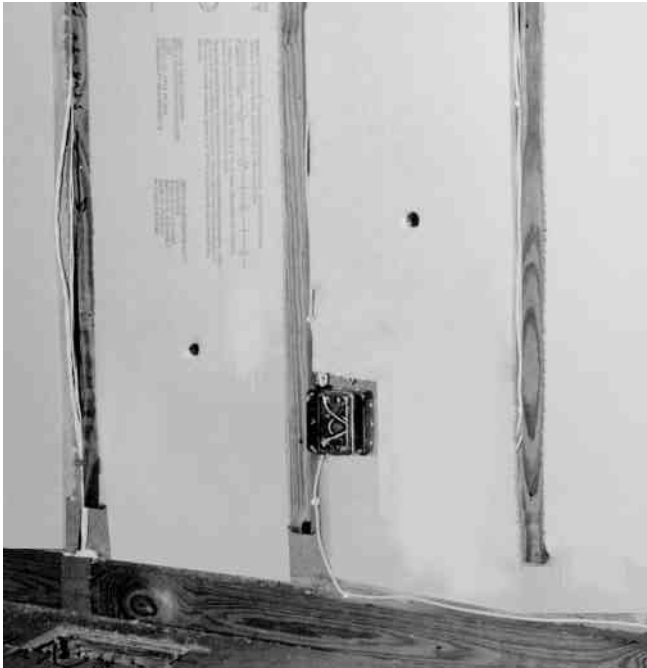

Figure 6-5: Electrical Installation in Insulated CMU Wall

Specialized tools, such as a hot knife or router, may be used to create the holes or channels in foam insulation; refer to Fact Sheet 7 (FS-7) for information on these tools.

If holes are created in concrete masonry walls to accommodate standard electrical boxes, insulation should be placed behind and around the boxes to prevent air infiltration and increases in heating and cooling loads. Expanding foam is typically used to seal any penetrations created in the wall.

Regardless of how the interior wall finish system is installed, the electrical panel box may be installed directly to the concrete masonry wall or to plywood that is fastened to the wall. Plywood is typically installed to facilitate the attachment of the panel box to the wall and to anchor any wiring exiting the box to the wall. Some electrical panel boxes have holes in which the wiring enters through the back of the box as opposed to the top, bottom, or sides of the box. If wiring is to enter the back of the panel box, the wall will need to be furred out to allow proper clearance for primary lines.

## **PLUMBING INSTALLATION**

Plumbing may be installed on the interior face of a concrete masonry wall in a manner similar to electrical utility installation. Plumbing should not be installed in an exterior concrete masonry wall that is not protected by insulation or mechanical means (i.e., conductive heat tape) owing to the possibility of freezing, the presence of bond beams and filled vertical cores within the wall, and

consideration of cost, coordination, and access issues. In addition, some local jurisdictions require hose bibs to be “frost-proof”. Many of these concerns are also relevant to light-frame construction.

Although plumbing is not typically installed on exterior walls, plumbing may be installed on the interior face of exterior concrete masonry walls. In cold climates, attempts should be made to locate all plumbing within interior walls. The interior finish of a concrete masonry wall determines how plumbing is installed. Interior finish selections may be grouped into three general categories as follows:

- ✓ interior surface of CMU wall remains exposed;
- ✓ interior finish installed on furring strips; and
- ✓ interior finish installed on rigid foam insulation.

If the interior face of the concrete masonry wall is left exposed, plumbing is simply mounted on the wall with u-shaped brackets or strapping. This approach is typically acceptable in nonhabitable spaces.

If the interior finish is installed on furring strips and plans call for hiding the plumbing in the wall, larger furring strips or wall studs may be required for larger-diameter plumbing. Plumbing is then installed in a manner similar to light-frame construction; that is, vertical plumbing runs are placed between studs and horizontal plumbing runs are cut through studs. Refer to Figure 6-6, which illustrates the installation of plumbing for a kitchen sink on an exterior CMU wall.



Figure 6-6: Plumbing Rough-In on Exterior CMU Wall

If the interior finish is installed on rigid foam insulation, the installation of plumbing is similar to electrical utility installation because plumbing pipes are similar in diameter to electrical conduit. For larger-diameter plumbing, chases may be constructed, or thicker furring strips may be used.

If holes are created in concrete masonry walls for through-wall penetrations, insulation or sealant should be placed around the penetration to prevent air infiltration and loss of heating and cooling. Similarly, channels cut into foam insulation for plumbing should be insulated to provide the same insulation thickness as the undisturbed

surrounding insulation area. When plumbing penetrations are below grade, care should be taken to seal around the plumbing to prevent moisture seepage.

For through-wall plumbing penetrations, the use of a sleeve may be used. Typically a rigid plastic pipe, a sleeve is inserted into the wall by the mason during construction. After the wall is constructed, the utility line is simply inserted through the sleeve. The use of a sleeve requires coordination between the plumbing contractor and the mason during wall construction. For through-wall plumbing penetrations where a sleeve is not used, the plumber simply cuts a hole in the wall where needed. Refer to Figure 6-1, which illustrates the use of a sleeve for through-wall penetrations.

## **HVAC INSTALLATION**

The installation of HVAC (heating, ventilating, and air conditioning) ductwork is similar to that in light-frame construction. Vertical ductwork is typically placed near the center of the home to shorten duct runs and to reduce labor and material costs. If ductwork must be run along an exterior concrete masonry wall, a chase or other enclosure is typically constructed to keep the duct hidden and, if needed, insulated. For freon and other related lines that may penetrate a concrete masonry wall, refer to the discussion of through-wall penetrations and the use of sleeves in the previous sections.

## **INSULATING CONCRETE MASONRY UNIT**

The placement of utilities in insulating concrete masonry units generally follows the methods described above for standard concrete masonry units. Consult the manufacturer for detailed installation guidelines.

## **CONCLUSIONS**

Utility placement is different than in light-frame construction. Some of the unique considerations are presented herein and can be easily followed during construction. With increased exposure to concrete masonry construction, differences will become less of an issue.

## **RESOURCES**

### **NAHB Research Center, Inc.**

400 Prince George's Boulevard  
Upper Marlboro, Maryland 20774-8731  
☎ 800.638.8556  
🌐 <http://www.nahbrc.org>

### **National Concrete Masonry Association (NCMA)**

2302 Horse Pen Road  
Herndon, Virginia 20171-3499  
☎ 703.713.1900  
🌐 <http://www.ncma.org>

### **Portland Cement Association (PCA)**

5420 Old Orchard Road  
Skokie, Illinois 60077-1083  
☎ 847.966.6200  
🌐 <http://www.portcement.org>

### **U.S. Department of Housing and Urban Development (HUD)**

451 Seventh Street S.W.  
Washington, DC 20410  
☎ 202.708.4370  
🌐 <http://www.hud.gov>  
*Publications*  
☎ 800.245.2691  
🌐 <http://www.huduser.org>

### **The Wiremold Company**

60 Woodlawn Street  
West Hartford, Connecticut 06133-2500  
☎ 800.621.0049

# Tools and Fasteners

FS · 7

An information series on residential concrete masonry technology

## SUMMARY

Many fasteners and tools, such as trowels, levels, etc., are used in concrete masonry construction. However, this fact sheet focuses on tools and fasteners used to attach plumbing, mechanical and electrical utilities, and finishes to concrete masonry walls. The two different fastening methods are as follows:

- ✓ adhesives; and
- ✓ mechanical fasteners.

A general description of fasteners and tools follows. The fastening methods are applicable to a variety of fastening needs; refer to applications described in Table 7-1. For more specific information about individual fasteners and tools, refer to Tables 7-2 and 7-3 contained herein. This fact sheet does not include all possible methods; consult manufacturers' data.

*The examples contained herein are intended for illustrative purposes only. Some fasteners and tools are manufactured by more than one manufacturer and some products are proprietary. The intent is simply to illustrate the general appearance of items; it is not to endorse specific products or manufacturers. Consult tool and fastener manufacturers to determine whether they manufacture a specific product.*

## ADHESIVES

Adhesives are either used alone or with a mechanical fastener. Adhesives used alone are generally known as construction adhesives; however, construction adhesives may also be used in conjunction with mechanical fasteners.

For example, construction adhesives may be used to adhere drywall to a concrete masonry wall; however, a mechanical fastener may be used to attach the top of the drywall to the sill plate while the adhesive sets.

Adhesives used solely in combination with mechanical anchors are generally known as epoxy anchors. Epoxy anchors are composed of two or more components that, when mixed together, react to create a chemical bonding agent that sets in a given period; epoxy is available in prepackaged capsules and cartridges. Epoxy is inserted into the hole before fastener insertion and then gels or sets to create a strong bond between the interior surface of the hole and the fastener. There are a wide variety of anchors; however, they are typically used for "heavy-duty" connections.

## MECHANICAL FASTENERS

Several mechanical fasteners are available for concrete masonry construction. Each type of fastener is used for a specific application or type of base material. Fasteners may need a predrilled hole for installation or may be driven directly into place. Of course, some fasteners may be placed in grout before it sets. Refer to the tables contained herein for more information.

## TOOLS

Depending on the scope of work and the work environment, a variety of tools are available for concrete masonry construction. Table 7-3 highlights those tools specifically designed for use with concrete masonry. Refer to Table 7-3 for a discussion of each tool, including typical applications.

**Table 7-1: Fastening Methods by Application**

Fact Sheet Reference	Interfacing Item	Fastener	Application
<b>STRUCTURAL APPLICATIONS:</b>			
FS•2	Sill Plate	J-Bolt Anchor Strap Anchor Sill Plate Anchor Epoxy Set Anchor	Cast into grouted core. Placed in mortar joint during wall construction. Cast into grouted core. Installed after grouted core cures.

**Table 7-1: Fastening Methods by Application (cont'd.)**

<b>Fact Sheet Reference</b>	<b>Interfacing Item</b>	<b>Fastener</b>	<b>Application</b>
FS•2	Sill Plate	Expansion Anchor	Installed after grouted core cures.
FS•2, FS•3	Direct-Bearing Joist Hanger	J-Bolt Epoxy Set Anchor Expansion Anchor	Cast into grouted core. Installed after grouted core cures. Installed after grouted core cures.
FS•2, FS•3	Ledger Board or Steel Ledger Angle	J-Bolt Anchor Epoxy Set Anchor Expansion Anchor	Cast into grouted core. Installed after grouted core cures. Installed after grouted core cures.
FS•2, FS•3	Clip Angle for Steel Framing	J-Bolt Anchor Epoxy Set Anchor Expansion Anchor	Cast into grouted core. Installed after grouted core cures. Installed after grouted core cures.
FS•3	Top Plate	J-Bolt Anchor Top Plate Anchor	Cast into grouted core. Cast into grouted core.
FS•3	Roof System	Truss or Rafter Anchor	Cast into grouted core.

**FINISH APPLICATIONS:**

FS•4	Brick Veneer	Wall Tie (Corrugated Brick Tie)	Placed in mortar joint during wall construction.
FS•4	NovaBrik™ by Allan Block Corporation	Consult Manufacturer	Installed in accordance with the manufacturer's instructions.
FS•4	Brick Veneer Backer Board	Consult Manufacturer	Installed in accordance with the manufacturer's instructions.
FS•4	Stone Veneer	Stone Anchor	Placed in mortar joint.
FS•4	Cultured Stone Veneer	Mortar	Applied to wall surface.
FS•4	Wood Furring Strips	Powder-Actuated Fastener Hard Cut Masonry Nail Fluted Masonry Nail	Driven into wall face. Driven into wall face. Driven into wall face.
FS•4	Cold-Formed Metal Furring Strips (Hat or Z Channels)	Powder-Actuated Fasteners Fluted Masonry Nail	Driven into wall face. Driven into wall face.
FS•4	Stucco and Decorative Masonry Finish	Not Applicable	Finish system is applied to wall face.
FS•4	Exterior Insulated Finish System	Consult Manufacturer.	Installed in accordance with the manufacturer's instructions.
FS•4	Gypsum Board	Construction Adhesive	Applied to wall face.
FS•4	Laminate Insulation-Gypsum Board	Construction Adhesive	Applied to wall face.
FS•4	Wallpaper	Manufacturer's Adhesive	Applied to wall face.

**INSULATION APPLICATIONS:**

FS•5	Surface Insulation	Construction Adhesive Insulation Fastener	Applied to wall face. Driven into wall face.
------	--------------------	--	---

**UTILITY APPLICATIONS:**

FS•6	Electrical Box	Nail Anchor	Installed in hollow or solid wall.
FS•6	Electrical Conduit	U-Shaped Brackets with self-tapping screws	Installed in hollow or solid wall.

## CONCLUSIONS

Few things make a job more difficult than not having the correct tools and fasteners. It is important when selecting the correct tools and fasteners to consider anchorage capacity and the base material. In addition, some fasteners require the fixture be in place at time of insertion; such a requirement should also be taken into account when selecting fasteners.

Many tools are designed to accomplish a particular task. A few “generic” examples are discussed herein; however, each tool and fastener manufacturer produces its own variations. Many tool and fastener manufacturers have their own patented products designed specifically for use with concrete masonry construction. Other products are designed for use with concrete. These latter fasteners may also work well when used with grouted concrete masonry.

The apparent lack of a fastener that will “work” for a specific application should rarely be a factor. If this seems to be the case, confer with local supplier or manufacturer representatives and data to identify alternatives that will achieve the desired result.

## RESOURCES

### **Avalon Concepts, Corporation**

1055 Leisz’s Bridge Road  
Leesport, Pennsylvania 19533  
☎ 800.636.8864  
🌐 <http://www.avalonconcepts.com>

### **Hilti, International**

5400 South 122<sup>nd</sup> East Avenue  
Tulsa, Oklahoma 74146  
☎ 800.879.8000  
🌐 <http://www.hilti.com>

### **Illinois Products, Corporation**

1030 Atlantic Drive  
West Chicago, Illinois 60185  
☎ 800.383.8183

### **Industrial Fasteners Institute (IFI)**

1717 East Ninth Street, Suite 1105  
Cleveland, Ohio 44114-2879  
☎ 216.241.1482  
🌐 <http://www.ifi-fasteners.org>

### **NAHB Research Center, Inc.**

400 Prince George’s Boulevard  
Upper Marlboro, Maryland 20774-8731  
☎ 800.638.8556  
🌐 <http://www.nahbrc.org>

### **National Concrete Masonry Association (NCMA)**

2302 Horse Pen Road  
Herndon, Virginia 20171-3499  
☎ 703.713.1900  
🌐 <http://www.ncma.org>

### **Paslode®, an Illinois Tool Works Company**

888 Forest Edge Drive  
Vernon Hills, Illinois 60061  
☎ 800.682.3428  
🌐 <http://www.paslode.com>

### **Portland Cement Association (PCA)**

5420 Old Orchard Road  
Skokie, Illinois 60077-1083  
☎ 847.966.6200  
🌐 <http://www.portcement.org>

### **Power Tool Institute (PTI)**

1300 Sumner Avenue  
Cleveland, Ohio 44115  
☎ 216.241.7333  
🌐 <http://www.taol.com/pti>

### **Quickpoint™, Inc.**

23B Bradford Street  
Concord, Massachusetts 01742  
☎ 800.368.2292  
🌐 <http://www.tiac.net/users/quikpnt>

### **Simpson Strong-Tie**

4637 Chabot Drive, Suite 200  
Pleasanton, California 94588  
☎ 800.999.5099  
🌐 <http://www.strongtie.com>

### **U.S. Department of Housing and Urban Development (HUD)**

451 Seventh Street, S.W., Suite 8132  
Washington, DC 20410  
☎ 202.708.4370  
🌐 <http://www.hud.gov>  
*Publications*  
☎ 800.245.2691  
🌐 <http://www.huduser.org>