

**VOL 2**



THE **REHAB** GUIDE

# EXTERIOR WALLS



PATH (Partnership for Advancing Technology in Housing) is a new private/public effort to develop, demonstrate, and gain widespread market acceptance for the “Next Generation” of American housing. Through the use of new or innovative technologies the goal of PATH is to improve the quality, durability, environmental efficiency, and affordability of tomorrow’s homes.

Initiated at the request of the White House, PATH is managed and supported by the Department of Housing and Urban Development (HUD). In addition, all Federal Agencies that engage in housing research and technology development are PATH Partners, including the Departments of Energy and Commerce, as well as the Environmental Protection Agency (EPA) and the Federal Emergency Management Agency (FEMA). State and local governments and other participants from the public sector are also partners in PATH. Product manufacturers, home builders, insurance companies, and lenders represent private industry in the PATH partnership.

To learn more about PATH, please contact:

PATH  
Suite B 133  
451 Seventh Street SW.  
Washington, DC 20410  
202-708-4250 (fax)  
e-mail: [pathnet@pathnet.org](mailto:pathnet@pathnet.org)  
website: [www.pathnet.org](http://www.pathnet.org)

## **DISCLAIMER**

The statements and conclusions contained in this report are those of Steven Winter Associates, Inc. and do not necessarily reflect the views of the Department of Housing and Urban Development. Steven Winter Associates, Inc. has made every effort to verify the accuracy and appropriateness of the report’s content. However, no guarantee of the accuracy or completeness of the information or acceptability for compliance with any industry standard or mandatory requirement of any code, law, or regulation is either offered or implied. The products listed in the report are included only as examples of some available products. No endorsement, recommendation, or evaluation of these products or their use is given or implied.

# EXTERIOR WALLS

VOLUME 2 OF THE REHAB GUIDE

## TABLE OF CONTENTS

FOREWORD **3**

1. INTRODUCTION **4**
2. DESIGN & ENGINEERING **6**
3. MASONRY/BRICK VENEER **21**
4. SHEATHING **28**
5. VAPOR RETARDERS & AIR INFILTRATION BARRIERS **32**
6. INSULATION **39**
7. VINYL SIDING **45**
8. METAL SIDING **49**
9. WOOD SHINGLES & SHAKES **52**
10. SOLID WOOD SIDING **55**
11. HARDBOARD SIDING **60**
12. ENGINEERED WOOD SIDING **63**
13. PLYWOOD PANEL SIDING **65**
14. FIBER-CEMENT SIDING **68**
15. EIFS & STUCCO **72**
16. EXTERIOR TRIM **77**
17. SEALANTS & CAULKS **80**
18. PAINT & OTHER FINISHES **84**

APPENDIX: PROFESSIONAL ASSOCIATIONS & RESEARCH CENTERS **89**

Prepared for:  
U.S. Department of Housing  
and Urban Development  
Office of Policy Development  
and Research

Prepared by:  
Steven Winter Associates, Inc.  
Building Systems Consultants  
Norwalk, CT

Contract DUI00C000005956  
August 1999

## CREDITS

STEVEN WINTER ASSOCIATES, INC. STAFF MEMBERS  
WHO WERE INSTRUMENTAL IN THE DEVELOPMENT AND  
PRODUCTION OF THIS GUIDEBOOK INCLUDE:

Steven Winter  
*Principal-in-charge*

Alexander Grinnell  
*Project manager and principal researcher*

Michael J. Crosbie, Ph.D., RA  
*Editor-in-chief*

Christoph Weigel and Masaki Furkawa  
*Illustrators*

Gordon Tully, William Zoeller  
*Project team members*

U.S. DEPARTMENT OF HOUSING AND URBAN DEVELOPMENT  
OFFICE OF POLICY DEVELOPMENT AND RESEARCH, AFFORDABLE  
HOUSING RESEARCH AND TECHNOLOGY DIVISION

David Engel  
*Director*

Nelson Carbonell  
*Senior architect*

### GUIDEBOOK DESIGN

Andrew P. Kner  
*Art Director*

Michele L. Trombley  
*Assistant Art Director*

Elizabeth Rosen  
*Symbols*

# FOREWORD

President Clinton recognizes that research and technological innovation are crucial if America is to meet its affordable housing needs. In 1998, the President introduced a major new initiative: The Partnership for Advancing Technology in Housing (PATH). This initiative brings together leaders from the home building, product manufacturing, insurance, and financial industries, as well as representatives from federal agencies, to spur housing design and construction innovations.

Thanks to the development of new machinery and materials and the creation of new technologies and techniques, the construction industry has made great progress. But a breakthrough material, a labor-saving tool, or a cost-cutting technique is only valuable if it is widely adopted, which means the construction industry must first become aware of these new developments.

The Department of Housing and Urban Development can help. We have commissioned a set of guidebooks that will present state-of-the-art techniques, materials, and technologies for housing rehabilitation. This volume, *Exterior Walls*, is the second of nine guidebooks—known collectively as *The Rehab Guide*—that will appear over the next few years.

We are presenting these guidebooks because, like research and technological innovation, housing rehabilitation is an essential component of America's commitment to provide affordable housing. I am pleased to present this important publication in the hope that it will become a valuable resource that leads to affordable, high quality rehabilitation, and thus to better housing for all Americans.

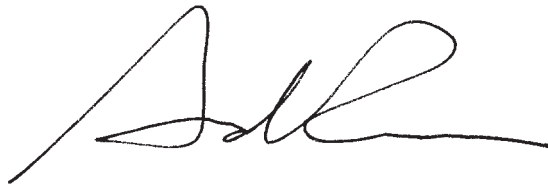
A handwritten signature in black ink, appearing to read 'A. Cuomo', with a long horizontal flourish extending to the right.

Andrew Cuomo, Secretary  
U.S. Department of Housing and Urban Development

# THE REHAB GUIDE: EXTERIOR WALLS

## INTRODUCTION

This publication, *The Rehab Guide: Exterior Walls* is one in a series of guidebooks produced by the U.S. Department of Housing and Urban Development (HUD) to keep the design and construction industry abreast of innovations and state-of-the-art materials and practices in home rehabilitation. As is too often the case, innovative techniques, materials, technologies, and products are slow to make their way into accepted practice. *The Rehab Guide* series is intended to accelerate this process by informing builders, architects, engineers, and other housing rehabilitation professionals about such innovations and state-of-the-art practices.

*The Rehab Guide* was also prompted by the lack of a comprehensive publication to make the design and construction industry aware of innovative and cost-saving developments in housing rehabilitation. Professional trade magazines, conferences, and trade shows offer some distribution of this information, but they are rarely focused on housing rehabilitation, as this series is, nor are they comprehensive. It is evident that such innovations will not advance unless the industry is made aware of them and they are tested.

### FOCUS OF THE REHAB GUIDE

The focus of this series is on housing rehabilitation, which is different than home improvement. Rehabilitate means “to restore to good condition,” not necessarily to improve to a state that is significantly different than the original. This is a fine line, but it distinguishes this series from “home improvement” books written for the amateur. *The Rehab Guide* focuses on building technology, materials, components, and techniques rather than “projects” such as adding a new room, converting a garage into a den, or finishing an attic. Nor is *The Rehab Guide* intended to be a “diagnostic” tool; a number of such books are already available to the industry.

The content for this guidebook, *Exterior Walls*, has been gathered from professionals in the housing rehabilitation field; manufacturers and suppliers of innovative technologies, materials, components, tools, and equipment; trade shows, conferences, reports, and publications considering such issues; trade organizations; and building research centers.

### A NOTE ON SOURCES

Particularly useful sources of technical information on exterior wall design and construction are publications by APA--The Engineered Wood Association, the Cedar Shake and Shingle Bureau, the Brick Industries Association, the Western Wood Products Association, the California Redwood Association and other industry associations. Other valuable and detailed sources of information from the general construction industry include technical trade magazines such as *Construction Specifier* and *RSI Roofing Siding Insulation* magazine. Publications relating more directly to residential construction include the *Journal of Light Construction*, *Old House Journal*, *This Old House*, *Fine Homebuilding*, *Energy Design Update*,

*Environmental Building News*, *Preservation Briefs*, and publications of the Forest Products Laboratory of the U.S. Department of Agriculture. A valuable source of publications on wall construction is the Canada Mortgage and Housing Corporation, which has an extensive catalog of excellent books and articles on a wide range of subjects on housing construction and rehab. The most complete and comprehensive books on exterior wall construction materials are the product information and installation manuals of individual manufacturers. Other valuable resources are the *Troubleshooting Guide to Residential Construction*, produced by the *Journal of Light Construction*, and *Rehabilitation of Wood-Frame Homes*, produced by the U. S. Department of Agriculture.

## HOW THE GUIDE IS ORGANIZED

Nine volumes will eventually make up *The Rehab Guide* in its entirety, and they are listed on the back cover of this volume. Each one is devoted to distinct elements of the house, and within each volume is a range of issues that are common to that element of home rehabilitation work. The present volume on Exterior Walls covers the major wall enclosure systems including framing and sheathing; protective strategies such as building paper, flashing, and housewraps; energy and air infiltration issues; various cladding materials; and trim. Each volume addresses a wide range techniques, materials, and tools, and recommendations based on regional differences around the country. Throughout *The Rehab Guide*, special attention is given to issues related to energy efficiency, accessible design, and sustainability.

## EASILY ACCESSIBLE FORMAT

*The Rehab Guide* is written and presented in a format intended for easy use. The spiral bound volumes open flat so that they can be easily photocopied, and they can be assembled and stored in a single three-ring binder. Within each volume, drawings, photos, and other graphic materials supplement written descriptions of a broad range of items: state-of-the-art and innovative building technology, products, materials, components, construction and management techniques, tools, equipment, software—virtually any and all items that make housing rehabilitation more efficient in terms of cost and time. While the content focuses on present technologies, techniques, and materials that are currently part of the house-building industry, *The Rehab Guide* also includes information on materials, products, and procedures from other construction sectors (such as commercial, industrial, institutional) that are relevant to housing rehabilitation.

The information is organized in different sections according to rehab subjects, and under headings that make this book easy to understand. “Essential Knowledge” gives the reader a basic overview of the important issues related to the section heading. Next, “Techniques, Materials, Tools” presents state-of-the-art and innovative approaches to accomplishing the work. Each entry is explained in detail, including its advantages and disadvantages. This makes it easy for readers to compare approaches and choose the one that is most applicable to their particular project. By design, the “Techniques, Materials, Tools” section is an overview, not a detailed description of implementation. “Further Reading” lists the valuable resources relevant to the subject which readers can go to for more detailed information. Finally, “Product Information” provides names and addresses of manufacturers of products, materials, systems, and components mentioned in the text so that more information can be attained. By virtue of their being listed here, such products are not necessarily being recommended; their existence and availability is being brought to the reader’s attention. New products should be carefully evaluated in the field as to their efficacy. The product lists are not comprehensive, and we encourage readers to bring new materials and products to our attention to be included in later editions of *The Rehab Guide*.

# 2

# DESIGN & ENGINEERING

## 2.1

## EXTERIOR WALL OVERVIEW

From the time of the first European settlers in North America, the predominant wall framing system for houses was timber (with wood exterior cladding). Also popular, but to a lesser degree than wood framing, was masonry construction (most commonly brick or stone). Other exterior wall systems less widely used included log construction and adobe.

In the first half of the 19th Century, the introduction of machine-sawn lumber and factory-made nails led to lighter structural systems (Fig. 1), including braced-frame construction, (which combines timber framing and infill studs), and balloon framing, which replaced heavy timber columns and girts (beams) with light-weight framing members that ran continuously from the foundation to the roof. By the beginning of World War II, balloon framing had largely been replaced with platform framing, which uses shorter framing pieces and gains lateral stability from the floor platform. This system prevails today in both stick-built and prefabricated housing.

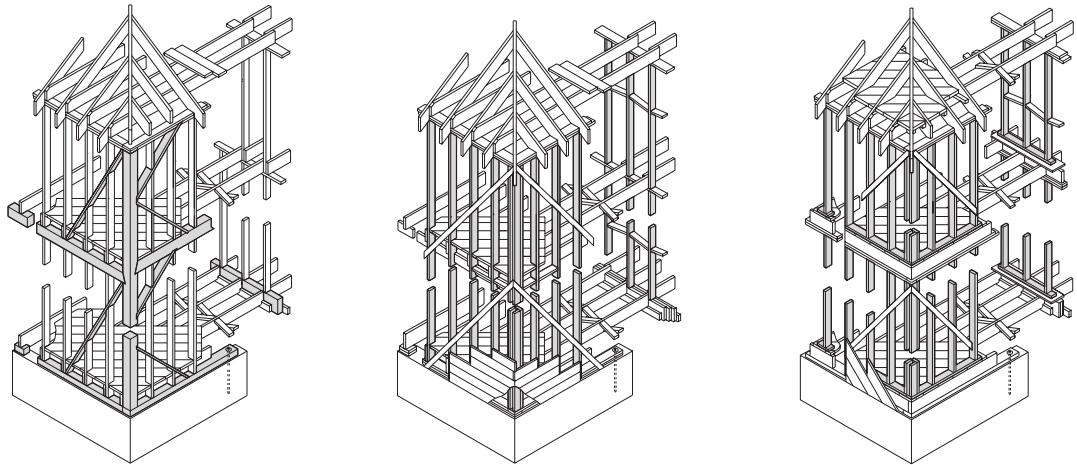

FIGURE 1

BRACED FRAMING

BALLOON FRAMING

PLATFORM FRAMING

Because it has been the dominant framing material, the rehabilitation of wood-frame systems will be given the most attention in this guide. Masonry systems such as stone, brick, and concrete block will be addressed briefly. Additional recommendations for remedial work will be addressed in the individual chapters that discuss specific wall materials and application systems. Steel framing has not been used extensively in residential rehab, except occasionally for interior non-load-bearing partitions. Structural



insulated panels (SIPs) have also not been used much in residential rehab work, because it is rare that large sections of walls are completely replaced.

Older, pre-code-complying domestic structures employed carpenters' rules of thumb and build-ings were, for the most part, strong, resilient, and adequate for normal conditions. When buildings fail structurally, which is infrequent, it is typically due to one or more of the following causes: inadequate design, earthquakes, storms and high winds, fire, insect damage, and structural deterioration caused by moisture. This chapter will outline some of the causes of structural failure, and recommended remedial approaches and reference sources to be contacted for additional recommendations.

## FURTHER READING

"The Structure of Wood Frame Homes," Gordon Bock, *Old-House Journal*, March/April 1992.

# 2.2

## WOOD FRAME SEISMIC RESISTANCE

### ESSENTIAL KNOWLEDGE

A house's load-bearing walls and columns transmit live and dead loads from the roof to the foundation, which in turn distributes these loads to the ground. Resistance is also needed to lateral forces from wind and seismic occurrences, which can cause racking and displace buildings from their foundations. These loads are taken into account in the design of newer code-complying buildings, but for houses constructed before state and local code enforcement it is likely that they were not specifically addressed. For instance, the use of anchor bolts was not uniformly enforced until the late-1950s, and seismic requirements were not developed and enforced until the early-1960s.

The most serious structural damage to wood-frame houses in seismic areas results from insufficient anchoring of the frame to the foundation, and the collapse of "cripple walls" in crawlspaces. Local municipalities, working on their own and with code agencies, have developed prescriptive standards that are accepted by local building departments and insurance providers. Typical standards, such as those approved by the city of San Leandro, California, are described below. Other municipalities may reference the *Uniform Code for Building Conservation* (UCBC), 1994 edition, or 1997 for seismic requirements. Codes are evolving, may vary among municipalities, and should be researched carefully.

### TECHNIQUES, MATERIALS, TOOLS

#### 1. ATTACH A SILL TO THE FOUNDATION WITH ANCHOR BOLTS.

Unreinforced brick and block foundations are problematic because anchor bolts are difficult to drill and install properly, and the mortar may not be strong enough to hold the wall together in an earthquake. Crumbling, cracked, or porous concrete cannot hold mechanical anchors and will tend to shear adjacent to epoxied anchor bolts (inadequate or substandard foundations should be rebuilt or replaced to current code standards). Reinforced concrete foundations are preferable, but they are not typical in older homes. If the foundation is adequate and there is sufficient height in the crawlspace to use an impact/rotary drill, the easiest method of attachment of a sill is by means of an expansion bolt or an anchor bolt epoxied into the foundation (Fig. 2). Sills should be bolted at a maximum of 6 foot intervals with bolts located within 12 inches of each joint or step in the sill, but not less than 9 inches from the end of a sill board. In addition, or in lieu of, conventional anchor bolts, special hold-down brackets are often installed at shear walls or at wall openings. These hold-downs secure the studs/post through the bottom plate into the foun-

ditions (Fig. 3). Specific reinforcement requirements will depend on individual site and building code requirements and should be reviewed with a structural engineer.

ADVANTAGES: Simplest, most positive connection.

DISADVANTAGES: May not be possible where there is insufficient headroom to drill.

## 2. ATTACH A SILL, JOIST, OR STUD TO THE FOUNDATION WITH SIDE BRACKETS OR STRAPS.

Where it is not possible to install anchor bolts because of insufficient headroom, a variety of fasteners has been specially developed to affix frames to foundations. Anchors are available from manufacturers such as Simpson Strong-Tie Co., Inc., among others. Typical products include straps and plates designed for attachment of plates and joists to the face of foundations and mud sills (Fig. 4).

ADVANTAGES: Can connect walls to foundations in areas with limited headroom.

DISADVANTAGES: Not as strong or direct a connection as anchor bolts.

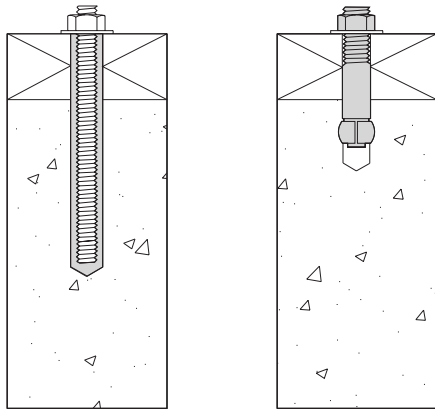

FIGURE 2

EPOXIED ANCHOR BOLT, EXPANSION ANCHOR BOLT

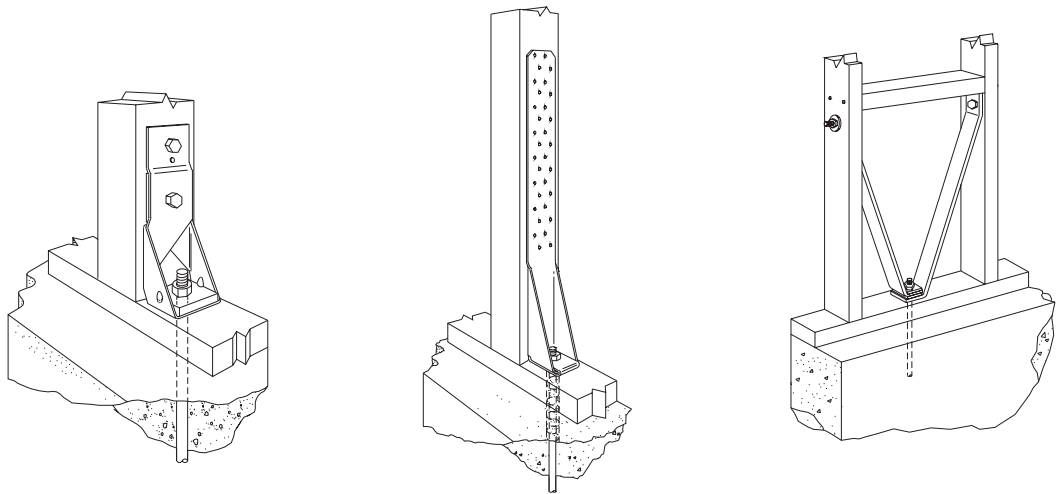

FIGURE 3

TYPICAL HOLD-DOWNS

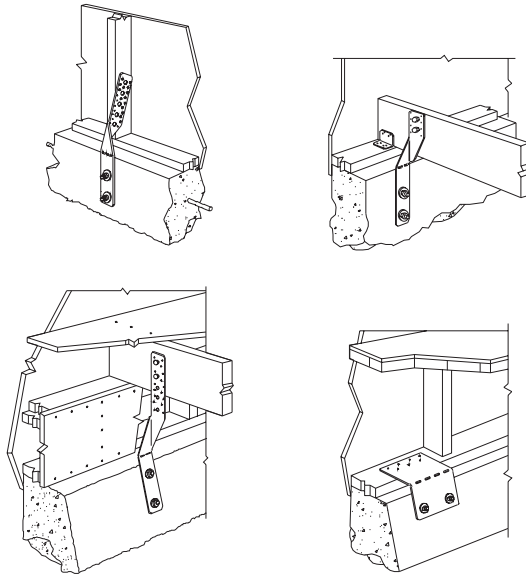

FIGURE 4

TYPICAL ANCHORS

### 3. REINFORCE CRIPPLE WALLS WITH PLYWOOD OR OSB.

The lateral forces of an earthquake are concentrated on the interface of the foundation and the wood frame. Cripple walls are inherently weak connections and have to be reinforced to prevent buckling and collapse. This is easily accomplished with plywood or oriented strand board (OSB) structural sheathing used as a rigid diaphragm connecting the top and bottom plates with the studs (Fig 5). The selection of the proper fastener type and spacing is critical. For crawlspaces that are not accessible, most municipalities have standards for the application of plywood or alternative structural sheathing to the outside of the crawlspaces. Consultation with a licensed engineer is recommended.

ADVANTAGES: An inexpensive and effective remedy.

DISADVANTAGES: Requires accessible crawlspace, otherwise existing siding and sheathing have to be removed and new sheathing applied to the building exterior.

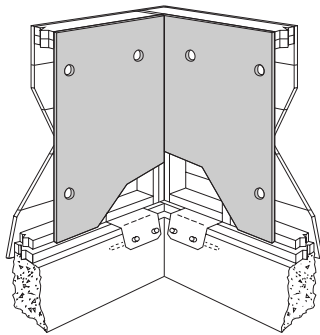

FIGURE 5

PLYWOOD REINFORCEMENT

#### 4. PROVIDE SECURE LOAD PATH FROM ROOF TO FOUNDATION.

Engineers recommend that a continuous “load path” or “hold down path” be created with metal connectors or sheathing so the walls, floors, and roof act together as a structural unit. This is accomplished by providing, in addition to the wall/foundation connection, a secure load path between the walls and floors (in platform construction) and between the walls and the roof. Typical floor-to-floor connectors include bolted hold-downs with threaded rods or straps designed specifically for that use. The choice would depend on job-site conditions and loading requirements (Fig. 6). Another material used to tie building components together is plywood or OSB sheathing which provides a hold-down path and resists shear or racking forces. The lower portion of the plywood sheathing should connect the lower to the upper floor and be nailed into the bottom plate, the wall studs, the top plate and the second floor rim joist, the upper portion should connect the rim joists, bottom plate and studs, to the top wall plate (Fig. 7). In areas of high seismic probability, engineers may specify a top grade of plywood, Structural #1, in lieu of regular rated sheathing. Consultation with a licensed engineer is recommended. Wall/roof connections in seismic areas are reviewed in *Rehab Guide, Volume 3: Roofs*.

ADVANTAGES: Provides structural continuity to the entire house.

DISADVANTAGES: Costly, requires removal of siding and possibly sheathing.

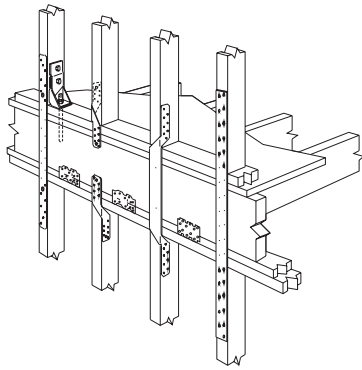

FIGURE 6

FLOOR-TO-FLOOR CONNECTIONS

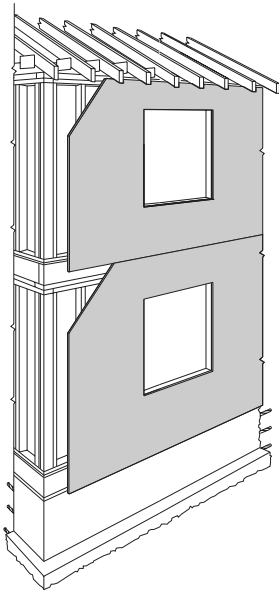

FIGURE 7

SHEATHING RESISTS SHEAR AND RACKING

## FURTHER READING

*A Guide to Strengthening and Repairing Your Home Before the Next Earthquake.* Developed by the Governor's Office of Emergency Services, State of California, and the Federal Emergency Management Agency, revised May 1995. Association of Bay Area Governments (ABAG) Publications, P.O. Box 2050, Oakland, CA 94604–2050.

*An Ounce of Prevention: Strengthening Your Wood Frame House for Earthquake Safety: A Do-It-Yourself Program.* Video and book. Governor's Office of Emergency Services, State of California, 1993. Association of Bay Area Governments (ABAG) Publications, P.O. Box 2050, Oakland, CA 94604–2050.

"Bracing Walls Against Racking," Harris Hyman, P.E., *Journal of Light Construction*, April 1987.

*Buildings at Risk: Wind Design Basics for Practicing Architects*, Michael J. Crosbie, Washington, DC: American Institute of Architects, 1998.

*How the City of San Leandro Can Help Strengthen Your Home for the Next Big Earthquake in the Bay Area* (publication includes prescriptive details). The City of San Leandro Development Services, Building Regulation Division, 835 East 14th Street, San Leandro, CA 94577; 510–577–3405.

*Prescriptive Seismic Strengthening Plan for Wood Frame Residential Structures*, Simpson Strong-Tie Co., 1996.

*Rehab Guide, Volume 3: Roofs*, Washington, DC: US Department of Housing and Urban Development, 1999.

*The San Francisco Bay Area—On Shaky Ground.* Association of Bay Area Governments, 1995 (multi-media CD-ROM, 1996). Association of Bay Area Governments (ABAG) Publications, P.O. Box 2050, Oakland, CA 94604–2050.

*Structural Strengthening for Seismic Conditions*, (Video 1997), Simpson Strong-Tie® Co.

"Tying Down the House," John Scoggins, *Journal of Light Construction*, September 1997.

## PRODUCT INFORMATION

Earthquake Resistant Construction Connectors, Simpson Strong-Tie® Co., 4637 Chabot Drive, Suite 200, Pleasanton, CA 94588; 800–999–5099; [www.strongtie.com](http://www.strongtie.com).

United Steel Products Co. (USP), 703 Rogers Drive, Montgomery, MN 56069; 800–328–5934.

# 2.3

# WOOD FRAME WIND RESISTANCE

## ESSENTIAL KNOWLEDGE

Exterior walls, in combination with interior shear walls that brace them, resist perpendicular and lateral loads and uplift forces generated by high winds (which can tear off roofs and porches). The increasing amount of damage caused by hurricanes to the Gulf and Atlantic coastal states and the mounting costs to repair and replace existing structures demonstrate the need to better design, build, and retrofit houses for wind resistance.

While code requirements regarding wind resistance are extensive for new home construction, there are relatively few requirements for rehab of existing houses (unless the work is extensive enough to warrant bringing the entire building up to code). Exceptions to this occur in some municipalities, such as Dade County, Florida, which have specific requirements for rehabing existing buildings. Rehab guidelines regarding wind

resistance being considered by local, state, and model code agencies include the following recommendations. A key aspect of these considerations is whether to provide prescriptive “fixes” for simple building configurations or whether to require that a professional engineer or architect prescribe the specific details. The latter is recommended for complicated building geometries.

## TECHNIQUES, MATERIALS , TOOLS

### 1. REINFORCE CONNECTIONS OF WOOD-FRAME WALLS TO FOUNDATIONS.

Depending on the type of foundation and access possible, there are a number of anchor bolts, straps, or threaded-rod connections that can be used to reinforce the connection of the frame to the foundations. Many of these connectors are similar to those used in seismic areas. In Northern areas, crawl spaces might provide accessibility, while foundations in Southern regions are slab on grade or, along the coast, pilings or piers. Typical rehab options for reinforcement are shown in Figs. 3 and 4.

ADVANTAGES: Relatively simple, cost-effective remedies.

DISADVANTAGES: May involve removing exterior or interior finishes.

### 2. REINFORCE WOOD-FRAME WALLS FOR SHEAR RESISTANCE.

Winds cause lateral forces on buildings that can, in severe cases, displace and collapse the building walls. Resistance to these forces is provided by exterior and interior shear walls that brace the building's structure and transfer loads to the floors and foundations. The most effective shear walls are made of plywood or oriented strand board. Alternative systems include other structurally approved sheathings, let-in wood bracing, metal strapping, “T” bracing, or special stud connectors. For buildings that have qualifying structural sheathings, a cost-effective retrofit is to increase the number of fasteners or connectors from the sheathing to the studs or to add resistance with foamed-in-place adhesives such as Foam Seal<sup>®</sup> products. This can be accomplished with the removal and replacement of the siding.

ADVANTAGES: A simple way of providing shear resistance.

DISADVANTAGES: Will require removal of siding and may require removal of sheathing if it is not structurally adequate.

### 3. REINFORCE CONNECTIONS OF WOOD-FRAME WALLS TO FIRST FLOOR.

Connections are simple to make in new construction but difficult in rehab work unless the siding is removed to expose the wall sheathing. Metal straps similar to those used in seismic areas provide structural continuity from one building component to another (Figs. 5 and 6).

ADVANTAGES: Provides a continuous load path.

DISADVANTAGES: Requires removal of siding and sheathing, if it is structurally inadequate.

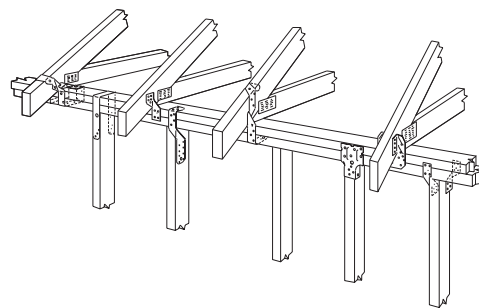

FIGURE 8

WALL/ROOF CONNECTORS

#### 4. REINFORCE CONNECTIONS OF WOOD-FRAME WALLS TO ROOF TRUSSES AND RAFTERS.

The connection of the exterior walls to the roof structure is the key element in transferring wind loads to the building frame and in preventing uplift forces from tearing off the roof. While new houses in high wind areas are required to have metal connectors, older houses most likely do not have them. The simplest connection is made from the outside after the soffit is removed (Fig. 8). This juncture can be reinforced from the inside, but the top portions of the wall as well as portions of the ceiling at the wall have to be removed for access. See *Rebab Guide, Volume 3: Roofs*, for further discussion.

ADVANTAGES: An effective means of providing uplift resistance.

DISADVANTAGES: Will require removal of soffit material.

#### 5. REINFORCE CONNECTIONS OF WOOD-FRAME WALLS TO ROOF OVERHANGS.

The most vulnerable portion of a building for wind uplift is the connection of roof overhangs and walls. The typical connection of the wall to the “ladder” overhang (Fig. 9) is inadequate if the overhang exceeds one foot in depth, and uplift forces can lead to separation of the ladder from the wall. The preferred detail on new or repaired construction is to use “lookouts” tied to the top of the exterior wall and anchored back to the adjoining truss or rafter (Fig. 10).

ADVANTAGES: Effective means of providing uplift resistance.

DISADVANTAGES: Will require removal of soffit and modification to gable end.

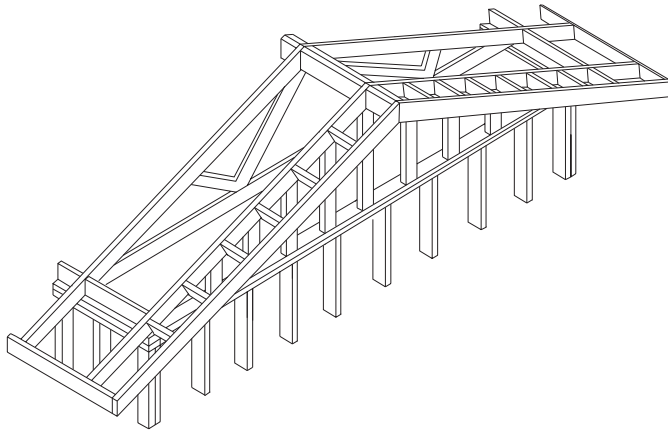

FIGURE 9

SHALLOW LADDER OVERHAND

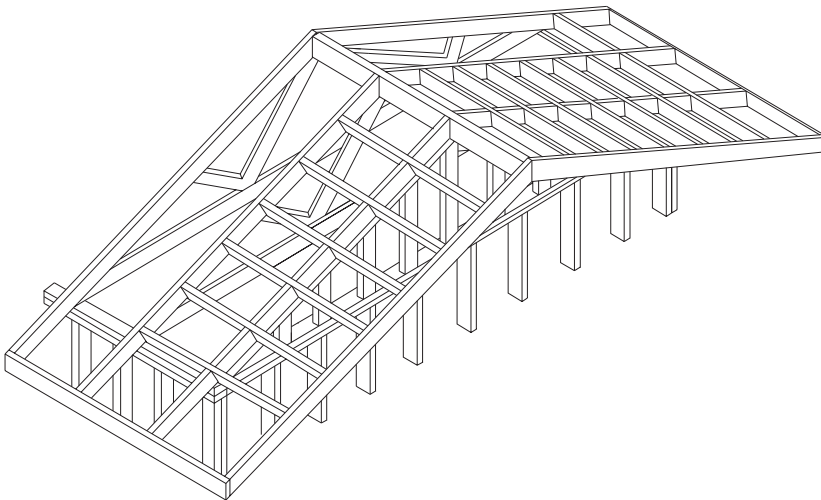

FIGURE 10

DEEP OVERHANGS SUPPORTED BY “LOOKOUTS”



## FURTHER READING

*Buildings at Risk – Wind Design Basics for Practicing Architects*, Michael J. Crosbie, Washington, DC: American Institute of Architects, 1998.

*Rehab Guide, Volume 3: Roofs*, Washington, DC: US Department of Housing and Urban Development, 1998.

## PRODUCT INFORMATION

*High-Wind-Resistant Construction Connectors*, Simpson Strong-Tie Co., Inc., 4637 Cabot Drive, Suite 200, Pleasanton, CA 94588; 800-999-5099; www.strongtie.com.

*High-Wind Retrofit of Wood Trusses or Rafters to Masonry or Concrete Walls*, Simpson Strong-Tie Co., Inc., 4637 Cabot Drive, Suite 200, Pleasanton, CA 94588; 800-999-5099; www.strongtie.com.

# 2.4

# REINFORCING EXISTING MASONRY WALL CONSTRUCTION

## ESSENTIAL KNOWLEDGE

It is often difficult to reinforce existing masonry walls for seismic or high wind resistance. Reinforcement strategies should be developed for individual buildings on a case-by-case basis by a licensed professional. Masonry buildings generally perform well in high wind as long as they are reinforced in accordance with codes, and as long as the connections to the roof structure are adequate to prevent uplift failure. Unreinforced masonry buildings perform poorly in seismic areas. The connection to roof structures and secondary structures such as porches are similar in concept to those used for wood-frame construction but adapted to masonry. Typical masonry-to-roof connectors are illustrated in Fig. 11.

**ADVANTAGES:** An effective means of providing uplift resistance.

**DISADVANTAGES:** Will require removal of soffit material.

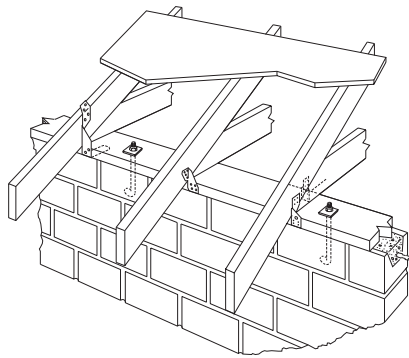

FIGURE 11

## MASONRY-TO-ROOF CONNECTORS

## PRODUCT INFORMATION

*High-Wind Retrofit of Wood Trusses or Rafters to Masonry or Concrete Walls*, Simpson Strong-Tie Co., Inc., 4637 Cabot Drive, Suite 200, Pleasanton, CA 94588; 800-999-5099; www.strongtie.com.



**ESSENTIAL KNOWLEDGE**

Water absorbed by structural wood-framing can raise its moisture content, reduce its compressive and tensile strength, ultimately cause rot and decay, and also attract termites. The most critical points of the building envelope susceptible to leakage are: tears or gaps in the roofing material; at flashings and penetrations of the roof plane; roof/wall connections; wall penetrations such as windows and doors; rainwater penetration through siding materials; and wall/foundation connections. Roofing water-related problems are discussed in the *Rehab Guide, Volume 3: Roofs*, wall penetration leaks at wall openings are covered in *Volume 4: Windows and Doors*, and water penetrations through wall materials are covered in other chapters of this volume.

Wall/foundation junctures are particularly critical because run-off from roofs and walls collects on the ground at that location. If the sill and floor assembly are not sufficiently elevated, rot will occur. Older timber-framed and balloon-framed structures with sill plates that rest on a few courses of stone (or, occasionally, directly on grade) are at greatest risk. Platform-framed houses that have foundation walls with the sill a minimum of 6 inches to 8 inches above grade (to comply with code minimums) are less susceptible to rot and decay from moisture. However, unless the grade below the siding is sufficiently sloped away and kept clear of debris and plantings, moisture can wick up through the siding and cause decay. Rot and decay cannot progress in the absence of moisture.

Sills can be inspected from inside the building in the crawl space or from outside by removing a portion of the siding and sheathing. The condition of the wood can be checked with a sharp object such as a screwdriver or pocket knife. Sound wood will split into fibrous splinters, while decayed wood will separate into small chunks of a dark brown, black, or gray color. Decay can also be revealed by rapping the surface of the wood member; a dull, hollow sound frequently indicates decay below the surface.

Decayed sills can be replaced with full-sized members, partially replaced with built-up lumber, or stabilized with structural epoxy conservation techniques.

**TECHNIQUES, MATERIALS, TOOLS****1. REPAIR SILL WITH BUILT-UP LUMBER.**

If the sill is a heavy timber section (4 by 6 to 8 by 8) and the wall studs are 3 or 4 inches wide, the house is most likely of post-and-beam construction. The roof and floor loads are transferred by means of beams (girts) to the columns and the studs between columns carry very little weight. Accordingly, it is possible to temporarily support the building at its bearing columns and replace sections of the sill below. If the building is balloon-framed or platform-framed, with individual studs carrying the load, the wall has to be supported along its length. Once the load is taken by the shoring, deteriorated sections of the sill can be removed with a reciprocating saw and a mallet and chisel. Pressure-treated sections of lumber can be scabbed (spliced) into the affected area (using APA-The Engineered Wood Association (APA) approved gap-filling adhesives) and fastened with galvanized drywall screws, spikes, or other rust-resistant fasteners. **ADVANTAGES:** Relatively simple fix for sills requiring isolated repairs.

**DISADVANTAGES:** Requires accurate assessment of sill condition; sections of rotting sill may be overlooked.

**2. REPLACE LARGE SECTIONS OR THE ENTIRE SILL.**

If significant decay runs the length of the sill, it should be replaced in its entirety. The exterior wall can be supported by jacking timbers placed next to the plate, running perpendicular to the joists (Fig. 12). Sections of the sill can be cut with a chain saw or reciprocating saw between joists that frame into the sill. A new sill is placed on top of the foundation. If the floor joists do not rest directly on top of the sill they can be hung from the new sill with joist hangers or, if the ends of the joists are not decayed, they can be mortised into the new sill. Replacing a sill is much easier with stud-framed houses, as individual joists rest

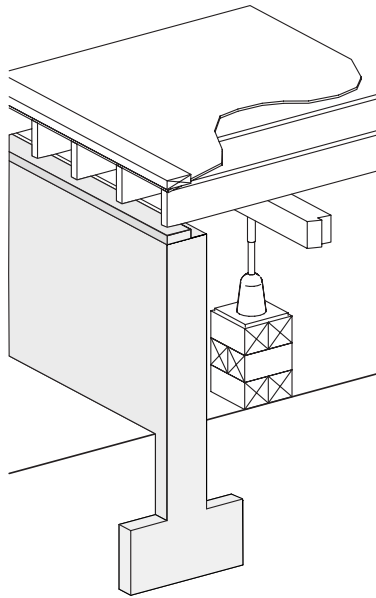

FIGURE 12

**JACKING FLOOR JOISTS**

on top of the sill. Because each stud of a load-bearing wall carries a relatively small portion of the load, the process of supporting the floor joists while removing the rotted sill or rim joist is relatively simple. Once the new sill is anchored to the foundation, the grade next to the wall should be sloped to provide drainage away from the wall.

**ADVANTAGES:** Replacing a major portion or the entire sill is a way to comprehensively address the problems of decay, and may be more cost-effective than a series of small, interim repairs.

**DISADVANTAGES:** Costly; might require extensive exterior sheathing and siding repairs.

**3. REPAIR PORTIONS OF THE FOUNDATION OR SUPPORTING COLUMNS USING EPOXY TECHNIQUES.**

Small portions of the foundation or columns that support structure above can be reconstituted and consolidated using liquid epoxy or epoxy putty (Fig. 13). This is particularly appropriate if the building is of historic significance.

**ADVANTAGES:** Can repair existing structure without removal.

**DISADVANTAGES:** Time consuming. Not practical with large areas of work.

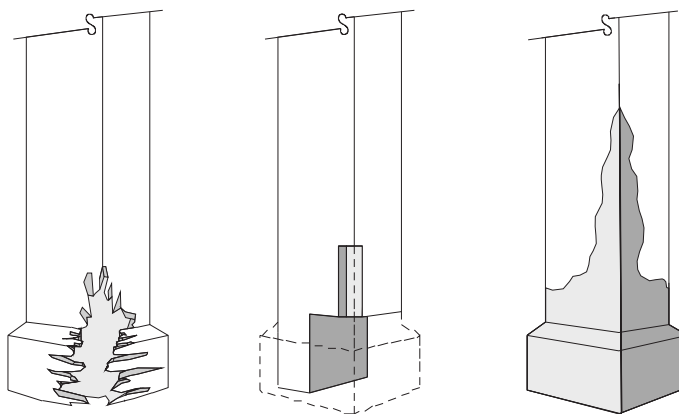

FIGURE 13

**EPOXY REPLACEMENT**

## FURTHER READING

*Renovating Old Houses*, George Nash, Newtown, CT: Taunton Press, 1996.

*Renovation: A Complete Guide* (Second Edition), Michael W. Lichfield, New York: Prentice Hall, 1991.

*The Old House Journal Guide to Restoration*, edited by Patricia Poore, New York: Dutton, 1992.

*Rehabilitation of Wood-Frame Homes*, USDA, Forest Service, Handbook No. 704, February 1998.

“Saving House Sills,” “Structural Repair Under Old Floors,” *Old House Journal*, March/April 1992.

“The Structure of Wood-Frame Houses,” *Old House Journal*, March/April 1992.

## PRODUCT INFORMATION

### IN-SITU STRUCTURAL REPAIRS

Preservation Resource Group, P.O. Box 1768, Rockville, MD 20849-1768; 301-309-2222.

Abatron, Inc. Wood Restoration Systems, 5501-95th Avenue, Department HP, Kenosha, WI 53144; 800-445-1754; www.abatron.com.

# 2.6

# MITIGATING INSECT DAMAGE

## ESSENTIAL KNOWLEDGE

Destructive insects include termites, carpenter ants, and wood-boring beetles (Fig.14). Termites access above-ground wood through cracks in foundation walls or slabs or build tubes from the ground up to the wood above to provide the necessary moist environment. Having infested the wood, they can live there indefinitely with no ground contact if the moisture level is adequate. Sources of moisture include roof leaks, condensation, or plumbing problems. Termites in crawlspaces may build free-hanging tubes from wood members to the ground. Evidence of termite infestation includes: the presence of mud tubes; damaged wood; active swarms of winged termites or large numbers of discarded wings or evidence of conducive conditions (e.g., moisture; wood-to-ground contact; inadequate ventilation; settlement cracks; and other likely entry points). Detection tools include: visual inspection; probing of the wood surface with a screwdriver or pocket knife; sounding (tapping) of the affected area with a hard object such as the handle of the screwdriver; the use of a moisture meter to detect likely environments; infestations; listening devices; electronic gas (methane) detectors; and fiber optic devices to inspect areas otherwise inaccessible to visual inspections. Many species of termites prefer wood that has been previously invaded by fungi. To guard against drying, termites consume wood only until the outer shell remains, leaving the wood looking intact. Wood that has been tunneled by termites will sound hollow when tapped with a solid object. Termites will attack all types of wood including redwood, cypress, and junipers if the wood has aged and the chemicals that provide termite-resistance (alcohols, oils, gums and resins) have leached out. Termites have been known to penetrate and damage many non-cellulosic materials such as drywall, plaster, stucco, and plastics. Items damaged include some softer metals (e.g., lead, copper, aluminum). Insulation board used as a substrate for Exterior Insulation and Finish Systems (EIFS) has often been riddled by termites leading to the prohibition of foam plastic within 8" of the ground in states with very heavy infestation of termites.

Ants are the most reported pests in many parts of the country and range from the arctic to the tropics. Carpenter ants, the major group that damages buildings, tunnel through wood but do not consume it for food. Main colonies of carpenter ants, given their name because they typically dwell in and

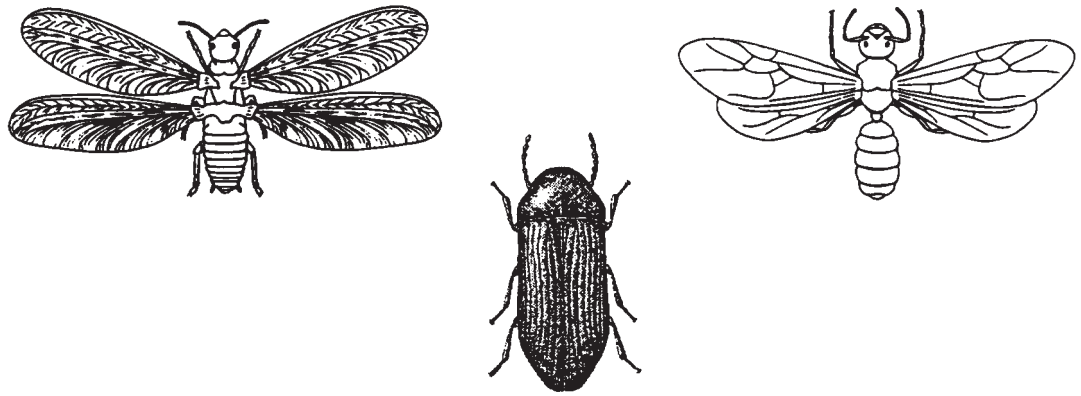

FIGURE 14

TERMITE

POWDERPOST BEETLE

CARPENTER ANT

excavate wood, are located in trees surrounding the infested structures. Inside buildings, satellite colonies will nest in a variety of voids including walls, hollow doors, behind appliances, in floor cavities and attic rafter spaces, under kitchen cabinets, bathroom fixtures, etc. Carpenter ant infestations can be located by their very presence or by piles of “frass,” pieces of dead ants and other insects mixed in with bits of wood.

There is a variety of wood-boring beetles. Among the best known and most destructive are the powderpost, roundhead, and flathead beetles. Some beetles attack both hardwood and softwoods, usually limiting their feeding to the sapwood portion. Their presence is usually indicated by frass and a number of exit holes in wood, although the number of holes does not necessarily indicate the activity or severity of infestation. The potential for damage is greatest when the infestations are new and the number of exit holes is low. Beetles are typically introduced into structures in building materials that have been infested at lumber yard stock piles, although they may also enter homes in finished wood products such as flooring, paneling, furniture, and firewood. Dead tree limbs may serve as a habitat from which flying adults may enter the house.

## TECHNIQUES, MATERIALS, TOOLS

### MITIGATE AND CONTROL INSECTS.

Mitigation methods to reduce the likelihood of termite infestations include: removal of all cellulous material on or beneath the soil adjacent to structures or in crawlspaces; eliminating details that allow materials to continue from the exterior wall into the soil; providing adequate clearance between grade and structural members to allow access and inspection of termite tunnels; eliminating dirt-filled porches, steps, and similar raised attachments; providing termite shields; and using pressure-preservative-treated lumber. Treatment strategies include the use of: liquid termiticides; termiticidal foams that fill cracks and gaps in materials and can be injected into soils; borate insecticides; and termite baits. The variety of treatment products is widespread and new products are being developed. The effectiveness of individual products, especially new ones, may vary depending on local soil and building-related conditions. Local pest control experts should be contacted for site-specific recommendations. Certain treatments may be prohibited by local authorities.

Mitigation methods for subterranean termites are of little benefit against drywood termites since infestations originate from “swarmers” entering through vents, cracks, or other openings. Drywood termites live within the affected wood. Their presence is indicated by piles of fecal pellets or discarded wings adjacent to holes or joints in the affected wood. Methods to control drywood termites include the use of: pressure-preservative-treated wood; sprayed insecticides; silica aerogel dust (a desiccant); borate dust; fumigation; heat treatment; and “drill-and-treat” with termiticides. Some new, and as yet unproven, strate-

gies include the use of microwave equipment and electrocution. Local pest control experts should be contacted for site-specific recommendations. Ant mitigation methods include: reducing moisture conditions; sealing cracks in the building's exterior; trimming trees away from the house roofs; keeping log piles away from houses; and eliminating wood-to-soil contact. Treatment strategies include a variety of sprayed insecticides, baits, and soil treatment. Treatment of affected houses for wood-boring beetles includes: removing infested wood; use of sprayed insecticides; fumigation; moisture reduction; and use of borate sprays. **ADVANTAGES:** Soil treatment and elimination of cellulose in backfill can be effective deterrents. **DISADVANTAGES:** New chemical treatments need replenishing sooner and are less effective than those approved in the past. Treatments can be costly.

## **FURTHER READING**

*Handbook of Pest Control*, Eighth Edition, Arnold Mallis, Mallis Handbook & Technical Training Company, 1997.

*The Approved Reference Procedures for Subterranean Termite Control*, National Pest Control Associations (NPCA), 1991.

## 2.7

# FIRE DAMAGE TO WOOD FRAMING

## **ESSENTIAL KNOWLEDGE**

Damage from fire can range from the total loss of a building and its contents to minor inconvenience from smoke odors. The process of determining the restoration requirements of a fire-damaged building varies considerably with the building location and extent of damage. Insurance adjusters often make settlement offers based on their own evaluation of restoration needs, although they may employ consultants on more complex projects. Recommendations may also originate from local fire marshals, building department officials, contractors, consulting engineers, industrial hygienists, public adjusters, and architects hired by the building owner. Unless the damage is limited, the restoration process can be complicated, involving structural, electrical, HVAC, and plumbing systems, as well as building finishes. In addition, significant health and comfort issues arise from the residual smoke, combustion gases, moisture from fire department hoses, and the existence of products containing asbestos. For these reasons the selection of a restoration contractor who is experienced and knowledgeable in current techniques is critical. At least one national association, the Association of Specialists in Cleaning and Restoration (ASCR) manages training and certification programs and publishes a restoration guideline.

## **TECHNIQUES, MATERIALS, TOOLS**

### **FIRE-DAMAGE RESTORATION.**

The first step in a restoration project is to assess the damage to the wall structure. In 2 by 4 construction, significantly charred members are generally removed in their entirety. Heavy timber construction can remain (according to the American Society of Civil Engineers), once the char is removed and if the remaining section is still structurally adequate (after a reduction-in-size-factor of 1/4 inch on all sides). Char is removed by scraping and abrasive blasting. It should generally be removed because it holds odors, although encapsulating coatings inhibit their transmittal. New construction, replacing the damaged construction, should meet codes for new construction. Smoke-damaged materials should be cleaned and deodorized as necessary. The use of ozone generators, sometimes used to remove odors and contaminants, is controversial and considered by a number of specialists to be ineffective and potentially dangerous (see Further Reading).

ADVANTAGES: Restoration can be relatively effective in removing odors when fire damage is slight.

DISADVANTAGES: Restoration after serious fires is expensive and complicated. Finding competent restoration professions is sometimes difficult.

## **FURTHER READING**

*Evaluation, Maintenance, and Upgrading of Wood Structures*, American Society of Civil Engineers.

“Research Sheds New, Unfavorable Light on Ozone Generators,” *IEQ Strategies*, P.O. Box 129, Center Strafford, NH 03815–0129; 603–664–6942; [www.cutter.com/energy/](http://www.cutter.com/energy/).

*NIDR - Guidelines for Fire and Smoke Damage Repair*, National Institute for Disaster Restoration (a division of the Association of Specialists in Cleaning and Restoration); 1997; 410–729–9900; [www.ascr.org](http://www.ascr.org).

*Odor Removal Manual, Volume I*, Clifford B. Zlotnik, Unsmoke Systems, Inc.

*Restoration Technology, Volume I*, Clifford B. Zlotnik, Unsmoke Systems, Inc.

## **PRODUCT INFORMATION**

Unsmoke Systems, Inc., 1135 Braddock Avenue, Braddock, PA 15104; 800–332–6037.

# 3

# MASONRY/ BRICK VENEER

Brick and stone masonry are among the oldest, long-lasting, and most versatile materials. Throughout the U.S. many brick homes, centuries old, continue to perform well. In many regions brick is the predominant building material because of its low maintenance, non-combustibility, availability, moisture resistance, and aesthetic appeal.

Any corrective work should be preceded by a careful visual assessment of the wall's conditions to determine overall patterns of deterioration and distress so that underlying problems can be appraised and corrected. Some common problems include foundation displacement (see *Rehab Guide, Volume 1: Foundations*); water penetration into the wall assembly; inappropriate material choices; poor construction practices; stresses caused by expansion and contraction due to temperature changes; shrinkage of the wood structural walls; and routine aging of the masonry facing and joints.

This chapter focuses on repair and rehabilitation of brick masonry, primarily clay and concrete brick veneer wall construction, as this is the most common construction type, although many of the recommendations apply also to stone, concrete block, and solid brick construction. Topics include cleaning, protective coatings, repointing, and repair.

## 3.1

## CLEAN EXISTING MASONRY WALLS

### ESSENTIAL KNOWLEDGE

The decision to clean a masonry veneer facade requires careful consideration because the cleaning process may remove weathered material as well as accumulated dirt. It might be justified if the dirt and pollutants (such as that from acidic rain, efflorescence, bird droppings, deteriorated paint, etc.) are having a harmful effect on the wall, however, "lightening up" the facade for cosmetic reasons may not be prudent. The benefits of cleaning should be weighed against the possibility of adverse affects on the masonry surfaces and mortar joints, as well as on flashing, windows, and other elements.

The least invasive cleaning is usually recommended; improper or over-cleaning can cause irreparable damage. Cleaning strategies for historic buildings should be reviewed with a restoration professional. All cleaning procedures and materials should be tested prior to the start of the project. For large jobs, the test area should be a minimum of 20 square feet. Before chemical cleaners are used, the wall should be saturated with water to avoid staining by heavy concentrations of cleaning agents. A waiting period of at least one week after finishing the test area is recommended in order to judge the results of the cleaning procedure, especially if chemical agents are used. For recommendations on cleaning specific stains see Further Reading.

### TECHNIQUES, MATERIALS, TOOLS

#### 1. CLEAN WITH BRUSH BY HAND.

This technique employs a variety of cleaning agents including water, detergents, proprietary cleaners, and



acid. Efflorescence can often be removed by dry brushing, with pressurized water, or with proprietary cleaners. Dirt can be removed with water or with a detergent solution such as trisodium phosphate and laundry detergents dissolved in water. Many stains can be removed with conventional “kitchen cleaners.” Other stains, resulting from leaching of salts or coloring agents within the brick, require acid cleaners, which should be used very carefully in diluted form. Some acids, such as hydrochloric (muriatic acid) can seriously degrade mortar. Acid can also discolor lighter masonry surfaces and damage metal, glass, marble, terra cotta, limestone, and cast stone surfaces, and can also leave a white film that is difficult to remove. Walls treated with acid must be thoroughly flushed with water after cleaning.

**ADVANTAGES:** Easiest and most conservative approach. Employs the widest variety of cleaning options. Allows for most cost-effective approach. Can confirm the appropriateness of cleaning strategies prior to large-scale application.

**DISADVANTAGES:** Appropriate only for relatively small areas. Time consuming; requires direct access to wall surfaces.

## **2. CLEAN WITH PRESSURIZED WATER.**

Useful in covering large areas, pressurized cleaning may be accomplished with low- or moderate-pressure water, steam, or water in combination with detergents or other cleaning solutions. Walls should be saturated with water prior to cleaning and completely flushed after cleaning. Care should be taken with acidic compounds as discussed above.

**ADVANTAGES:** Cost-effective for large areas; can reach heights of 100 feet.

**DISADVANTAGES:** Requires specialized equipment. Nozzle pressures in excess of 700 psi may damage brick, especially sand-finished material, and erode mortar joints. May not remove certain stains as effectively as brush cleaning by hand. Disposal of water run-off may be a problem. Excess water can bring soluble salts from within the masonry to the surface. Cannot be used during periods of freezing weather. Steam cleaning with or without chemicals may be useful in removing paint and embedded grime, but requires careful analysis, testing, and experienced professionals. Can be costly.

## **3. CLEAN BY ABRASIVE-BLASTING.**

Abrasive-blasting, usually with sand, is often considered a means of last resort, and in many cases is prohibited because it can erode ornamental details and destroy or scar brick and stone faces. Less abrasive and softer aggregates than sand, such as glass and plastic beads, and organic matter such as finely ground nut shells, wheat starch, peach and apricot pits, and cherrystones, are sometimes used on small sections of decorative brick, stone or metal elements.

**ADVANTAGES:** Will clean when other techniques will not.

**DISADVANTAGES:** Potentially destructive; use only after careful analysis and testing. May be prohibited.

## **FURTHER READING**

“The Cleaning and Waterproof Coating of Masonry Buildings,” *Preservation Briefs*, No. 1, Robert C. Mark, National Park Service, Washington, D.C., 1975.

“Cleaning Brick Masonry,” Brick Industries Association Technical Note #20, Rev. 11, November 1990.

“Gentle Blasting—New Methods of Abrasive Cleaning,” Valerie Sivinski, *Old House Journal*, July/Aug. 1996.

“Moisture Resistance of Brick Masonry,” BIA Technical Note #7E, January 1987.



# APPLY COLORLESS PROTECTIVE COATINGS

## ESSENTIAL KNOWLEDGE

Colorless coatings are sometimes considered for masonry walls in order to enhance water resistance or to repel graffiti. The chemicals used fall within two classifications: films and penetrates. These two have significantly different physical properties and performance. Whereas these coatings may have some limited usefulness, in many cases they provide little or no advantages, require frequent replacement, and can have adverse effects. Brick manufacturers should be contacted for recommendations on the use of colorless coatings.

## TECHNIQUES, MATERIALS, TOOLS

### 1. APPLY FILM COATING TO MASONRY WALL.

Products include acrylics, stearates, mineral gum waxes, urethane, and silicone resins. The large molecular size of these materials prevents them from penetrating into the masonry.

**ADVANTAGES:** Can reduce the absorption of some bricks and can bridge hairline cracks. Can keep surfaces clean and help prevent graffiti from penetration into the masonry surface.

**DISADVANTAGES:** Can inhibit evaporation of water within the masonry through the exterior face, which can cause the coating to cloud or spall under some freeze/thaw conditions. Generally not recommended in such environments. Sheen or gloss may darken material. Vulnerable to cracking due to thermal fluctuations. Urethane often breaks down under Ultraviolet light. Silicones do not chemically bond with substrate, and as a result have a short life.

### 2. APPLY PENETRATING COATING TO MASONRY WALL.

These coatings typically penetrate into the masonry to depths up to  $\frac{3}{8}$  inch, due to their small molecular structure. Materials include silane and siloxanes that chemically bond with silica- or aluminum-content materials to make them water repellent. These coatings are not generally necessary on new walls or brick veneer walls with drainage cavities.

**ADVANTAGES:** Coatings can last up to 10 years, decrease absorption, and increase water repellence. Unlike film coatings, penetrating coatings allow wall to breathe. Siloxanes have been shown to be effective on some multi-wythe brick barrier walls where water penetration is a problem.

**DISADVANTAGES:** May have limited lifetime; cannot be applied over film coatings. May react with other building materials. Can kill vegetation and emit harmful vapors. Will not seal cracks in mortar joints.

## FURTHER READING

“Colorless Coatings for Brick Masonry,” BIA Technical Note #6A April 1995.

## 3.3

# REPOINT EXISTING WALLS

### ESSENTIAL KNOWLEDGE

While the service life of many types of brick can exceed 100 years, the longevity of mortar joints, depending on the exposure, is closer to 25 years, according to the Brick Industries Association (BIA). At some point the mortar joint will fail, allowing water to enter the wall cavity. Conditions that require repointing may include: mortar erosion more than 1/4 inch, crumbling mortar, and hairline cracks in the mortar and between the mortar and brick.

### TECHNIQUES, MATERIALS, TOOLS

#### REPOINT EXISTING WALL.

Visual observation in combination with a light scraping with a metal tool can detect most deficiencies. Other conditions requiring repairs beyond repointing are discussed in section 3.4. Where repointing work is undertaken on houses of special architectural or historical significance, advice should be sought from a preservation specialist. Portland cement mortar was not used before the beginning of the 20th century. To avoid serious brick damage the compressive strength of the repointing mortar should be similar to or weaker than that of the original mortar. If it is not, dead loads and stresses from the expansion and contraction of the brick can transfer loads through the new mortar into the brick and can spall and crack the brick face. Mortars used in more recent construction include types N and O (Table 1).

TABLE 1

MORTAR TYPES AND INGREDIENTS BY VOLUME

| Type | Cement | Hydrated Lime | Sand |
|------|--------|---------------|------|
| N    | 1      | 1             | 6    |
| O    | 1      | 2             | 9    |
| K    | 1      | 4             | 15   |

ADVANTAGES: Repointing walls can stabilize deterioration, strengthen walls, and provide weathertightness.

DISADVANTAGES: Costly, may require scaffolding. Requires skilled and thorough mechanics.

### FURTHER READING

“Mortars for Brick Masonry,” BIA Technical Note #8, revised Aug. 1995.

“Repointing (Tuckpointing) Brick Masonry,” BIA Engineering and Research Document #622.

## 3.4

# REPAIR EXISTING MASONRY WALLS

### ESSENTIAL KNOWLEDGE

There are certain conditions where repointing alone is not effective and replacement of a portion of a wall may be required. Some of these include:

■ Wall cracking associated with thermal movement: Such cracks are cyclical and will open and close with thermal swings. These cracks may gradually expand as dislodged mortar accumulates in the crack after

each cycle. The cracks should be cleaned and protected with flexible sealants. Remortaring cyclical cracks will prevent them from closing and may lead to further cracking. In some instances, the masonry may need to be cut and expansion joints installed.

■ Wall cracking associated with moisture penetration and caused by freeze/thaw cycles and corrosion: Examples include cracking around sills, cornices, eaves, parapets, joints between dissimilar materials, and other elements subject to water penetration and freezing; cracking around clogged or non-functioning weep holes at lintels and at the base of brick veneer cavity walls. A number of companies, including Mortar Net™ and Heckman Building Products, Inc., make plastic mesh products for cavity wall construction that suspend mortar droppings above the weep holes, thereby reducing the chance of blocking them with mortar debris (Fig. 1). Mortar Net™ also makes a vertical insert between bricks that acts as a continuous weep (Fig. 2).

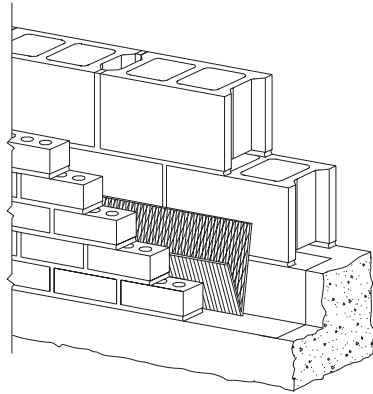

NO. 365 TRASH MORTAR DIVERTER

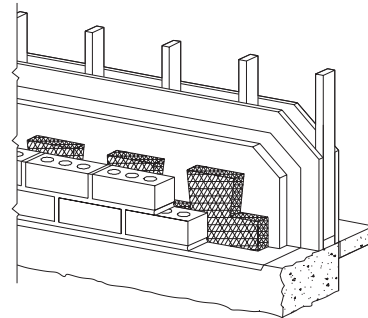

CAVITY DRAINAGE SYSTEM

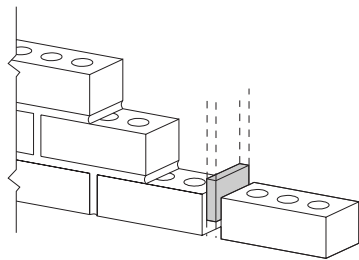

WEEP VENT

FIGURE 1

FIGURE 2

■ Wall cracking associated with failure of structural elements. Above-ground examples include cracking or displacement of brick over openings resulting from deflection or failure of lintels or the deterioration of mortar joints in masonry arches; cracking from outward displacement of sloped roofs due to lack or failure of collar ties; bulging and cracking of walls caused by deteriorated or inadequate wall ties; cracking due to inadequately supported point loads; cracking due to ground tremors, nearby construction, or heavy traffic. Light gauge (22 or 24 ga.) corrugated wall ties typically used in residential construction are not recommended, according to the BIA, for three reasons: the tie shape allows water to flow more freely to the interior of the wall; they are susceptible to corrosion; they have poor strength to transfer loads between the brick wythes and the building structure. Adjustable ties, similar to those recommended for use with metal studs, (Fig. 3) are preferred. Serious structural problems require a professional engineer's assistance in determining appropriate corrective measures.

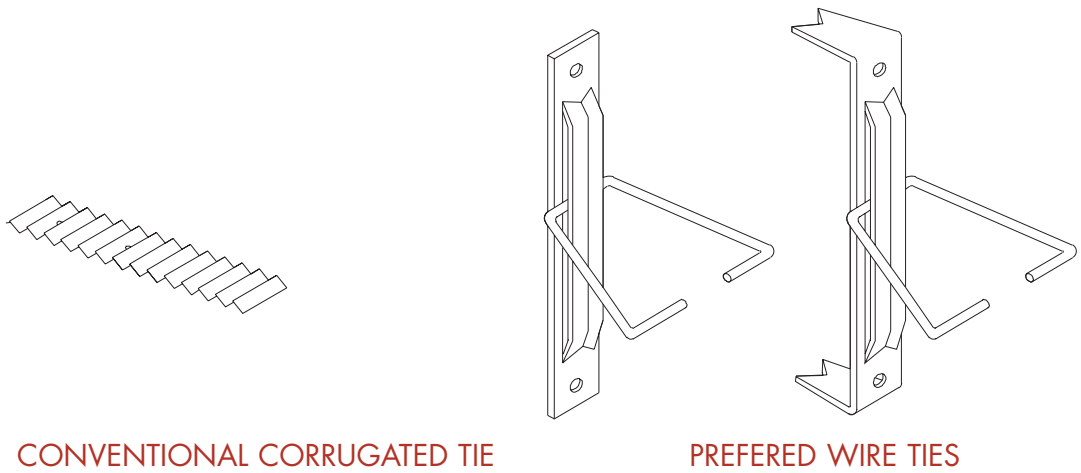

FIGURE 3

CONVENTIONAL CORRUGATED TIE

PREFERED WIRE TIES

■ **Deteriorated masonry:** A number of factors, in addition to structural distress, can contribute to the deterioration of a masonry wall, including weathering effects of rain, UV, temperature changes, as well as the effects of chemicals in the air or ground, inappropriate cleaning or coatings, and erosion from faulty leaders and down spouts.

## TECHNIQUES, MATERIALS, TOOLS

### REPAIR MASONRY WALL.

If individual bricks or masonry units, or sections of the masonry wall, require replacement, they may be removed relatively easily by cutting out the units to be replaced and replacing with new material. The arch action of masonry walls can often prevent adjacent sections from collapsing if the area to be removed is small. Alternatively, in the event that the masonry ties are missing or deteriorated, a number of companies make stabilization systems that connect exterior brick wythes with backup walls (Fig. 4). These are either mechanically-attached pins or ties that are drilled directly through the veneer into its substrate, or ties that are anchored to the substrate with epoxy cements (see Product Information). Consultation with a professional engineer is advised if the affected area of wall is significantly large, or if the brick failure is due to underlying structural problem.

**ADVANTAGES:** The repair or replacement of brick on low structures is relatively simple and cost-effective.  
**DISADVANTAGES:** Replaced brick and mortar will not match color of existing wall. The replacement of brick on high walls will require scaffolding and is costly.

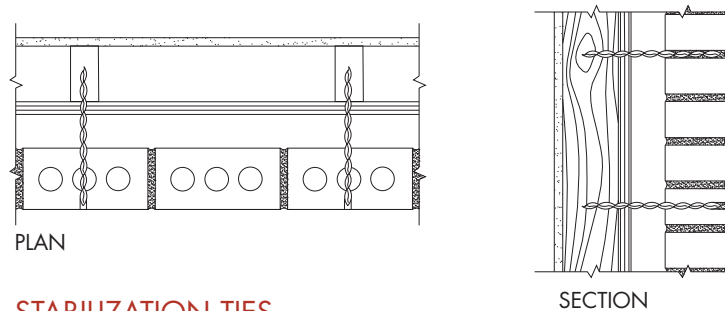

FIGURE 4

STABILIZATION TIES

## FURTHER READING

“Anchored Brick Veneer Wood Frame Construction,” BIA Technical Note #28, revised Aug. 1991.

“Brick Masonry Cavity Walls—Detailing,” BIA Technical Note #21B, Jan. 1987.

“Brick Veneer Basics,” Rob Swanson, *Journal of Light Construction*, June 1994.

“Brick Veneer Existing Construction,” BIA Technical Note #28A, Sept. 1988.

“Getting Started with Brick Veneer,” Steve Thomas, *Journal of Light Construction*, Nov. 1997.

“Guideline on the Rehabilitation of Walls, Windows, and Roofs,” U.S. Department of Housing and Urban Development, 1986.

“Guidelines for Residential Building Systems Inspection,” U.S. Department of Housing and Urban Development, 1986.

*Preservation Briefs 1: The Cleaning and Waterproof Coating of Masonry Buildings*, Robert C. Mark, U.S. National Park Service, Nov. 1975.

*Preservation Briefs 2: Repoint Mortar Joints in Historic Buildings*, Robert C. Mark, Patterson Tiller, and James S. Askins, U.S. National Park Service, Sept. 1980.

## PRODUCT INFORMATION

### DRAINAGE MESH

Mortar Net™ USA Ltd., 3641 Ridge Road, Highland, IN 46322; 800-664-6638; [www.mortarnet.com](http://www.mortarnet.com).

### BRICK TIES, ACCESSORIES, AND STABILIZATION SYSTEMS

Dur-o-Wal®, Inc., 3115 North Wilke Road, Suite A, Arlington Heights, IL 60004; 800-323-0090; [www.dur-o-wal.com](http://www.dur-o-wal.com)

Heckman Building Products, Inc., 4015 West Carroll Avenue, Chicago, IL 60674; 800-621-4140.

Helifix®, 30 Millwick Drive, Weston, Ontario, Canada M9L 1Y3; 800-561-3026.

Hohman and Bainard, Inc. 30 Rasons Court, P.O. Box 5270, Hauppauge, NY 11788-0270; 800-645-0616; [www.H-B.com](http://www.H-B.com).

**ESSENTIAL KNOWLEDGE**

Exterior wall sheathing serves a number of functions. It provides rigidity and shear resistance to the main framing elements; it is part of the barrier system that keeps out the destructive effects of moisture; it provides varying degrees of insulation; and it can serve as the nail base for exterior siding.

Until the mid-1960s, when plywood was introduced, the dominant sheathing material was 1-by-3-inch and 1-by-4-inch wood boards, typically nailed diagonally to the stud frame. Today the most common wall sheathing materials are oriented strand board and plywood, which together account for approximately 55 percent of the sheathing market, with slightly more plywood sold than OSB (other siding products are described below). It is important to recognize that APA - The Engineered Wood Association (APA) does not differentiate between plywood and oriented strand board (OSB) under its APA Rated Sheathing program. OSB prices have dropped by half over the past several years, and in some areas of the country it is about half the price of comparable plywood. OSB is expected to be the most common sheathing material by 2002.

If the finished siding has been well maintained, the wall sheathing should not have deteriorated. Exceptions to this would be deterioration from moisture trapped behind the finished siding. Moisture entry is due to improperly flashed or caulked joints between the siding and openings such as doors and windows; inadequate or poorly fabricated flashing at the wall/roof juncture; water driven by high winds between siding material during rain storms; moisture penetration through mortar joints in brick veneer walls; and the lack of, or improperly lapped, moisture retarder such as building paper or housewrap behind the siding. Much of the research into sheathing failure suggests that, particularly in the case of Exterior Insulation and Finish Systems (EIFS), it should be assumed that moisture will penetrate the finished siding and that provisions should be made to allow the system to be self-draining between the finish material and the sheathing by means of furring strips, drainage channels, plastic matting, or other devices.

**TECHNIQUES, MATERIALS, TOOLS****1. REPAIR EXISTING WALL SHEATHING.**

The specific sheathing repair will depend on the location and extent of damage and the type of sheathing encountered. There is very little possibility of consolidating existing sheathing material. Replacement is necessary if the material is unsound and can no longer function as intended. Replacement of sheathing will require removal and replacement of siding as well.

**ADVANTAGES:** Localized repairs of sheathing are cost-effective if the damage is limited.

**DISADVANTAGES:** Localized repairs will only mask the problems if they are widespread and result in a patchwork of new siding. If the problems are widespread the affected sheathing should be replaced in its entirety and new siding installed.

**2. REPLACE EXISTING SHEATHING WITH ORIENTED STRAND BOARD.**

Introduced in the early 1980s, OSB (made with rectangular-shaped wood strands cross-oriented in layers for better structural performance) has replaced particleboard, "flakeboard," "chipboard," and "waferboard" as the most popular alternative to plywood sheathing. OSB utilizes a variety of fast-growing wood species, including aspen, southern yellow pine, poplar, birch, and mixed hardwoods, with waterproof phenolic resin or polyisocyanate binders. Available in varying thicknesses, it typically comes in 4-by-8-foot sheets, but can also be custom ordered in lengths up to 24 feet and in widths up to 12 feet.

**ADVANTAGES:** Excellent shear resistance, dimensional stability, and bond durability under normal conditions.

Increasingly popular and readily available nationally. Economical (significantly less expensive than plywood). Recognized by all three model code agencies. Can serve as a nail base for a variety of siding material. DISADVANTAGES: Edges can swell if subject to continuous wetting. Has a relatively low R-factor of 1.25/inch.

### **3. REPLACE EXISTING SHEATHING WITH PLYWOOD.**

Structural plywood is generally identified in terms of the veneer grades (A-B, B-C, C-D) used on the face and back of the panels or sheets, or by a term suggesting the panel's intended use (APA Rated Sheathing). Veneer grades define appearance in terms of natural unrepaired growth characteristics and allowable number and size of repairs that may be made during manufacture. According to the APA-Engineered Wood Association, the minimum face veneer grade permitted in exterior plywood is C. D-grade veneer is used in panels intended for interior use or in applications protected from the weather. CDX (exterior adhesive) panels should not be used in applications where the plywood is permanently exposed to weather or moisture. According to APA, the "CDX" plywood is not a recognized grade designation. A better designation is (DOC) PS1-95 (a prescriptive standard that references plywood only). (DOC) PS2-92 is a performance standard that allows the supplier to submit either plywood or OSB. Plywood sheathing also comes in a structural - 1 grade, a higher performing grade than normal sheathing, which is used for shear walls in seismic areas.

ADVANTAGES: Long considered the highest-performing sheathing. Has excellent structural and weathering characteristics. Can be used as a nail base for virtually any type of siding, including both cements and synthetic stuccos, and brick veneer applications.

DISADVANTAGES: Considerably more expensive than similar structural sheathing such as OSB, thus losing market share. Has relatively low R-factor of 1.25/inch.

### **4. REPLACE EXISTING SHEATHING WITH FIBERBOARD SHEATHING.**

Fiberboard sheathing has a 40-year track record in the construction industry, and is in wide use throughout the country. Known under a variety of names, such as "blackboard," "grayboard," and "buffalo board," the material is made from recycled newspaper, wood fiber, and other cellulose products, held together with a binder. It is available in regular density, which requires additional corner bracing, and high density with sufficient racking strength to be used without additional bracing (unless required by local code officials).

ADVANTAGES: Historically less expensive than most other sheathing material. Has higher R-value (approx. 2.4/inch) than OSB, gypsum sheathing, and paper board sheathing. Is vapor-permeable. Can be used as a substrate for a variety of finish materials including stucco and wood.

DISADVANTAGES: Has a lower R-value than insulated sheathings. Cannot be used as a nail base for aluminum and vinyl clapboard siding (siding must be nailed to studs or furring strips). Becoming less cost-competitive with OSB in some areas.

### **5. REPLACE EXISTING SHEATHING WITH GYPSUM SHEATHING.**

In use for many years as a substrate for stucco, brick veneer, and a variety of other siding materials where fire-rated assemblies are required by code officials. There is a variety of different types of gypsum sheathing available as both nonfire-rated and fire-rated.

#### **5.1. PAPER-FACED GYPSUM SHEATHING.**

In use for over 30 years, combines a wax-treated water resistant gypsum core with a water repellent paper facing.

ADVANTAGES: Economical, widely available in 4-by-8-foot and 2 by 8 feet sheets of varying thickness. Relatively inexpensive sheathing for brick veneer, stucco, and EIFS. Provides fire ratings for a variety of assemblies.

DISADVANTAGES: Standard paper-faced gypsum cannot be left exposed for more than four weeks before applications of finish material. There have been problems with delamination of the paper face when used under exterior insulation finish systems (EIFS). Requires careful handling, as edges are subject to breakage.



### **5.2. GLASS MAT-FACED GYPSUM SHEATHING.**

A product recently developed by Georgia Pacific, Dens-Glass Gold™ combines inorganic glass mats embedded with a water resistant and silicone-treated gypsum core and an alkali-resistant surface treatment. The product is more water resistant and generally performs better than paper-faced gypsum sheathing, particularly as a substrate to EIFS and brick veneer. Available in 1/2- and 5/8-inch thicknesses and lengths of 8 to 10 feet, and greater on special order.

**ADVANTAGES:** Resistant to wicking, moisture penetration, and delamination. Can be installed and exposed up to six months before application of finish siding. Superior performance compared to paper-faced gypsum. Can be used as a substrate for a wide variety of siding applications, but not as a nail-base. Does not require additional bracing for normal applications. As light-weight and easy to handle as paper-faced sheathing.

**DISADVANTAGES:** Costs up to 50 percent more than paper-faced gypsum sheathing. R-value for 1/2-inch thickness is 0.56; 5/8-inch thickness is 0.67, which is considerably less than for insulative sheathing. Cannot be used as a nail base for siding.

### **5.3. GYPSUM SHEATHING MADE WITH A NON-PAPER-FACED BLEND OF CELLULOSE FIBER AND GYPSUM.**

Developed recently as a high-performing alternative to paper-faced boards by Louisiana Pacific, FiberBond™ fiber-reinforced wall sheathings are made from recycled newsprint, perlite, and gypsum, with a special water-resistant face treatment.

**ADVANTAGES:** Stronger and more moisture resistant than paper-faced boards. Structural wall bracing; superior resistance to screw withdrawal. Can be used as a substrate for EIFS, brick veneer, and a variety of other claddings. Higher impact strength than other gypsum sheathings; harder edges and ends. Available in up to 12-foot lengths. Uses recycled materials.

**DISADVANTAGES:** Somewhat heavier than other 4 x 8 sheets of gypsum sheathing (paper-faced: 56 pounds, Dens-Glass: 64 pounds, FiberBond: 72 pounds). Priced comparable to Dens-Glass; significantly more expensive than paper-faced. Unfinished exposure limited to 60 days. Cannot be used as a nail base for sidings.

### **6. REPLACE EXISTING SHEATHING WITH PAPERBOARD SHEATHING.**

In use for over 60 years, paperboard sheathing is a code- approved, low-cost alternative to the other structural sheathings, and has found a considerable following among large home builders for new construction. Available from Simplex Products Division (Thermo-Ply™) and other manufacturers, in thicknesses from 0.078 to 0.137 inch, it can be obtained in sheets up to 80 inches wide and 16 feet long, with both reflective foil surfaces and non-reflective. Vapor-permeable sheathing is under development. It is often available to builders with their own private label.

**ADVANTAGES:** Does not require additional shear bracing. Recognized as structural sheathing by national model codes. Less expensive than other sheathing alternatives. Excellent air infiltration resistance due to overlapping joints.

**DISADVANTAGES:** Thinness of the material makes it difficult to use in small-scale rehab projects as infill for thicker sheathing products. Not as strong as OSB or plywood. Sheathing material has R-value of 0.2, but is claimed to be greater with reflective surface and air space, but less than other insulating sheathing. May require adjustments to wood window trim detailing due to thinness of material. Cannot be used as a nail-base for siding products.

### **7. REPLACE EXISTING SHEATHING WITH FIBER-CEMENT SHEATHING.**

A number of fiber-cement sheathing products are available as structural sheathing underlayments. These products range from 30-year-old cement and wood fiber products such as Wonderboard, to high-tech fiber-cement products such as Hardiboard™ and Eternit™, which perform well in high-moisture locations. As such, they are frequently used as underlayments for thin brick, tile, and EIFS.

**ADVANTAGES:** Good performance in high-moisture locations. Resistant to face delamination. Noncombustible, strong, and rigid.

**DISADVANTAGES:** More costly than gypsum board and other types of sheathing. Not typically used for siding systems other than for EIFS.



## 8. REPLACE EXISTING SHEATHING WITH FOAM INSULATING SHEATHING.

With increased energy conservation mandated by state and model energy codes, and an increased awareness by the public of possible cost savings and environmental benefits, the use of insulating sheathings including polyisocyanurate (ISO), extruded polystyrene (XPS), and molded expanded polystyrene (EPS) has grown steadily. This is especially true with steel construction, which has potentially large heat losses through thermal bridging. Foam insulating sheathings generally are not structural and require structural sheathing underlayment, such as OSB, or other approved form of shear bracing; they require a 15-minute fire-rated barrier (usually gypsum) when used on the interior of habitable residential spaces. Foam insulating sheathings are discussed in Chapter 6, *Insulation*. See Product Information for a list of suppliers.

**ADVANTAGES:** Foam insulating sheathing provides the most energy-saving method of providing insulation on the outside of walls with R-values up to 7.7/inch for ISO insulation material. Provides a thermal break. Can also be used in cavity wall construction and as a substrate to stucco and EIFS systems.

**DISADVANTAGES:** Most foam sheathings are not structural sheathings. Applications of many siding products over foam sheathings require special nailing provisions (see individual siding manufacturers' specifications). Thicknesses of 1 inch and over present attachment problems to existing or new framing if not adequately addressed.

## FURTHER READING

*House Building Basics*, APA-Engineered Wood Association, APA Form X461, 1997.

*Oriented Strand Board*, APA-Engineered Wood Association, APA Form W410, April 1996.

*OSB Performance by Design*, Structural Board Association, 1997–98.

*Residential & Commercial Design/Construction Guide*, APA-Engineered Wood Association, APA Form E30, April 1996.

## PRODUCT INFORMATION

### PLYWOOD AND OSB

APA—The Engineered Wood Association, P.O. Box 11700, Tacoma, WA 98411–0700; 253–565–6600; [www.apawood.org](http://www.apawood.org).

### OSB

Structural Board Association, 45 Sheppard Avenue East, Suite 412, Willowdale, Ontario, Canada M2N 5W9; 416–730–9090; [www.sba-osb.com](http://www.sba-osb.com).

### RIGID FOAM INSULATION

Celotex Building Products, P.O. Box 31602, Tampa, FL 33631–3602; 813–873–4230.

Dow Chemical Company, Styrofoam Brand Products, 2020 Willard H. Dow Center, Midland, MI 48674; 800–258–2436.

Owens Corning, One Owens Corning Parkway, Toledo, OH 43659; 800–354–PINK or 800–GET–PINK.

Tenneco Building Products, 2907 Log Cabin Drive, Smyrna, GA 30080; 800–241–4402.

### RADIANT BARRIER/PAPER BOARD PRODUCTS

Energy-Brace™ reflective sheathing; Fiber-Lam, Inc., P.O. Box 2002, Doswell, VA 23047; 804–876–3135.

Thermo-ply™ reflective sheathing; Simplex Products Division, P.O. Box 10, Adrian, MI 49221; 517–263–8881.

# 5

# VAPOR RETARDERS & AIR INFILTRATION BARRIERS

## 5.1

## VAPOR RETARDER

### ESSENTIAL KNOWLEDGE

Vapor retarders first appeared in building construction in the 1920s. Early theories held that moisture vapor will migrate from a region of high concentration towards a region of low concentration along a linear path. The amount of moisture transfer is dependent on the differences in concentration and the vapor permeability of the membrane separating the two regions. This is the theory of vapor diffusion, which viewed the flow of moisture vapor directly analogous to the conductive flow of thermal energy. In this theory, air movement, and the moisture propelled by it, were not considered to be major factors. In the early 1950s, Canadian research found that air movement was the primary mechanism of moisture vapor migration. Without active air infiltration control, vapor retarder barriers become ineffective.

Current theory on vapor retarders indicates that both air infiltration and direct diffusion play significant roles in the transfer of moisture vapor and, therefore, both must be accounted for. Effective vapor retarders must have a water vapor permeability not exceeding 1.0 grains per hour per square foot per inch of mercury vapor pressure difference (referred to as 1.0 perms), and must be installed in such a manner as to prevent air leaks at joints and laps.

Although the issue of what makes a vapor retarder effective is generally settled, controversy still remains as to where to install it, if at all. From this standpoint, the authority on the subject is the 1997 *ASHRAE Handbook of Fundamentals*, which has more to say on the topic than any of the model codes. In what is defined as heating climates (4,000 heating degree days, base 65°F, or more), vapor retarders belong on the interior side of the insulation. In warm, humid, cooling climates (Florida and Gulf Coast) where moisture vapor transfer conditions are effectively reversed, vapor retarders are best placed close to the exterior.

In mixed climates (not fitting either of the above definitions), the vapor retarder should be placed to protect against the more serious condensation condition, summer or winter. If in a mixed climate the winter indoor relative humidity is kept below 35 percent, a vapor retarder at the interior side of the insulation is usually not required, and an exterior vapor retarder strategy is most effective. Where winter interior humidity is not controlled or if a humidifier is used, an interior vapor retarder is most useful.

Vapor retarders should never be placed on both sides of a wall. Where a vapor retarder is employed, the opposite wall surface must provide a permeable surface to allow drying to occur. Thus, in hot, humid, cooling climates, where a vapor retarder is employed at the exterior, the interior wall surfaces should be permeable. No vapor retarder paints, kraft-faced insulation, or vinyl wall coverings should be used. Conversely, in northern heating climates, with interior vapor retarders, the exterior wall coverings should be vapor permeable.

The primary purpose for installing a vapor retarder in residential rehabilitation is to minimize

moisture vapor migration into a wall or roof assembly where it has the potential to deposit condensate when the dew point is reached. The resulting water in liquid form may cause decay in structural wood framing, wood-based sheathing materials, and interior gypsum board or plaster wall coverings. The prolonged presence of moisture will also encourage and facilitate mold and mildew growth, raising potential serious health concerns for the homes' occupants.

## **TECHNIQUES, MATERIALS, TOOLS**

Vapor retarders can be classified into two major groups: flexible or coatings. Metal foils, laminated foils, treated paper, and plastic films are flexible sheet goods, while paint, semi-fluid mastic, and hot melt are coatings. In typical residential construction and rehabilitation, the commonly used materials are exterior- or interior-applied plastic films, interior-applied foil-faced products, interior treated paper-faced products, and interior paint coatings.

### **1. APPLY A VAPOR RETARDER PAINT COATING.**

A relatively new product on the market suitable for interior applications is vapor retarder paint. Produced by several manufacturers, including Sherwin-Williams and Glidden, vapor retarder paints are available as interior latex primers, typically with a perm rating of approximately 0.7. These primers are formulated to behave much like standard latex interior primers, in terms of consistency, coverage, and application. They are tintable and suitable for use over new gypsum board or previously painted surfaces. As with standard interior primers, normal prep work is needed, and stained areas will require a stain-hiding primer prior to application. The cost per gallon of the vapor barrier primers is generally competitive with standard interior primers.

**ADVANTAGES:** Vapor retarder primers are the simplest application in situations where existing wallboard or plaster surfaces are not to be significantly disturbed. Where interior primers are used, the vapor retarder function comes at virtually no additional cost. Can effectively upgrade the vapor transmission performance of an exterior frame wall with no more effort and cost than a new primer and finish coat paint application.

**DISADVANTAGES:** Appropriate for interior wall surface applications only. With the vapor retarder at the inside surface of the wall assembly, damage to the paint can compromise retarding ability. If required prepriming prep work is inadequate, the primer coat vapor retarder effectiveness will be diminished. To be fully effective, all penetrations and material intersections at the interior surface of the wall must be caulked or otherwise sealed.

### **2. INSTALL TREATED PAPER OR FOIL VAPOR RETARDERS.**

For residential rehabilitation purposes, treated paper and foil vapor barriers usually take the form of kraft and foil-faced batt installation. In a situation where interior wall finish has been removed and new exterior wall insulation is to be installed, kraft or foil-faced batts are cost-effective and do provide an adequate to marginal vapor barrier. The amount of unsealed edge is significant and does provide a path for moisture vapor migration. To improve effectiveness, the kraft or foil flanges can be installed over the face of the studs and lapped instead of stapled to the inner stud faces (Fig. 1). Convenient and cost-effective, kraft and foil batt insulation facings do have limitations and their use as a primary vapor barrier should be limited to applications where vapor barrier performance is not critical, such as in mixed, non-humid climates. In heating climates with 4,000 degree days or more, a more continuous vapor barrier surface should be considered.

**ADVANTAGES:** The most cost-effective interior vapor retarder strategy where exterior wall framing is exposed and new insulation is to be installed. Saves labor costs as fiberglass batt insulation and vapor retarder are installed in one step.

**DISADVANTAGES:** Installation requires that walls are stripped to rough framing and that fiberglass batt insulation be installed. The number of joints and edges inherent in this system make for a functionally marginal vapor retarder, but sufficient for mixed climates or where indoor humidity is controlled in heating climates. Performance can be improved by installing faced batts with flanges attached to narrow face of studs and lapped.

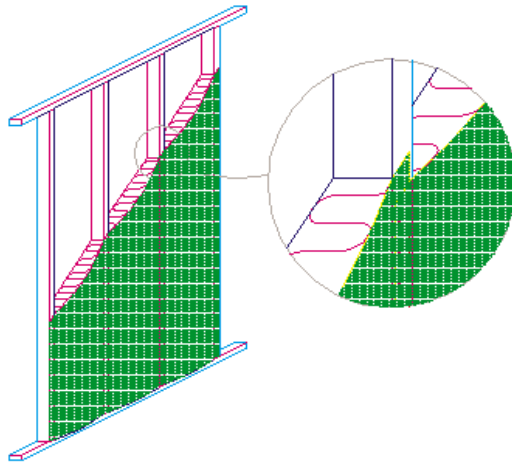

FIGURE 1

LAPPED FLANGE

### 3. INSTALL A CLEAR POLYETHYLENE VAPOR RETARDER.

Most plastic barrier films are either clear polyethylene, black polyethylene, cross-laminated polyethylene, or reinforced polyethylene. The most basic of these materials, clear polyethylene, is also the most economical. Available in 4-, 6-, and 10-mil thicknesses, it is best suited for interior wall applications over framing and insulation. As clear poly's content is up to 80 percent "reprocessed" material, it is also an environmentally sustainable choice. The high recycled content comes at a cost: its quality can be uneven and it generally has poor tear and puncture resistance. Clear poly should never be used for exterior applications or applications with more than limited exposure to sunlight. Clear poly is available in widths of 4 to 32 feet in 100-foot long rolls. As with all polyethylene vapor retarders, for horizontal application over wood framing, staples are most often used. For maximum effectiveness, joints should be kept to a minimum and seams should be lapped and taped. **ADVANTAGES:** Relatively inexpensive and easy to install. In more severe heating climates, the use of interior polyethylene films is most effective and is practical where interior finish surfaces are removed. Being transparent, attachments to framing members are simplified, as is the installation of wallboard material over the polyethylene, because the studs are visible.

**DISADVANTAGES:** Limited tear and puncture resistance. Clear poly must be installed with care to avoid damage. All penetrations such as electrical junction boxes must be taped and sealed to ensure effectiveness. Clear poly can be used only in instances where wall finishes and surfaces have been removed, fully exposing wall framing.

### 4. INSTALL A BLACK POLYETHYLENE VAPOR RETARDER.

Black polyethylene is nearly identical to clear poly, except for the addition of carbon black to the composition as a Ultraviolet inhibitor. This permits the use of the polyethylene where some limited exposure to sunlight is required, such as at exterior wall surfaces. Black polyethylene strength characteristics are similar to clear poly, with low tear and puncture resistance.

**ADVANTAGES:** For exterior wall surface applications in hot, humid, cooling climates, black UV protected poly films can provide superior vapor retarder performance.

**DISADVANTAGES:** Limited tear and puncture resistance. Unreinforced black poly must be installed with care to avoid damage. Its opaque nature makes installation more difficult by obscuring underlying framing, sheathing, and other components. Joints and seams must be lapped and taped for full effectiveness. Installation is limited to conditions where siding has been fully removed and attachment directly to exterior sheathing can be made.

### 5. INSTALL A CROSS-LAMINATED POLYETHYLENE OR FIBER-REINFORCED POLYETHYLENE VAPOR BARRIER.

Compared with standard polyethylene, high-density cross-laminated poly and fiber-reinforced poly are both specialty products manufactured for applications where higher strength is required. For retrofitting

over rough, irregular surfaces, such as solid board sheathing, both products would be less susceptible to tearing or puncture by lifted nail heads, splinters, or exposed sharp corner edges. Either product would also be appropriate where rough handling and adverse site conditions are expected.

**ADVANTAGES:** Stronger than standard poly, reinforced and laminated material can withstand more adverse site conditions and rough handling. The reinforced and laminated products are typically rated for limited UV exposure for exterior use and situations where the installation of siding and coverings is delayed. Black reinforced and laminated poly can be used as the required weather barrier under exterior siding and cladding.

**DISADVANTAGES:** Higher initial cost compared to standard black poly. Application is limited to conditions where siding and exterior wall coverings have been removed. Seams must be lapped and sealed for full effectiveness.

## **FURTHER READING**

*ASHRAE Handbook of Fundamentals*, Chapters 22–24. Atlanta: American Society of Heating, Refrigeration and Air Conditioning Engineers, 1997.

## **PRODUCT INFORMATION**

Sto-Cote Products, Inc., 218 South Road, Genoa City, WI 53128; 800–435–2621 (Tu-Tuf products).

Raven Industries, P.O. Box 5107, Sioux Falls, SD 57117–5107; 800–635–3456 (Rufco Moisture/Vapor Barriers).

Owens Corning, Fiberglass Tower, Toledo, OH 43659; 800–GET–PINK (kraft and foil-faced batt insulation).

Reef Industries, Inc., P.O. Box 750250, Houston, TX 77275–0250; 800–23–6074 (Griffolyn Reinforced Vapor Barriers).

# 5.2

# AIR INFILTRATION BARRIERS

## **ESSENTIAL KNOWLEDGE**

Air infiltration barriers, or “housewraps,” as they are known in the industry, have grown in popularity since their appearance in the 1970s in the wake of the energy crisis. DuPont, one of the first companies to introduce such a product, came out with Tyvek™ in the late 1970s. Today there is a variety of similar products that reduce air infiltration and improve energy performance.

The primary attribute of housewraps is their ability to operate as air infiltration barriers while not forming an impervious vapor barrier. When placed over the exterior surface of the wall sheathing, the material allows moisture vapor to escape from the frame wall cavity while reducing convective air movement in the insulation, thereby helping to maintain the composite R-value of the wall. The greater the exterior air movement, the greater the benefit.

The ten biggest selling housewrap products fall into one of two basic categories: perforated and non-perforated. Perforated products are either woven polyethylene, woven polypropylene, spun bonded polypropylene, or laminated polypropylene film. These materials are more impervious to moisture vapor migration than nonperforated wraps, thus are provided with “micro-perforations” to allow vapor migration and diminish their vapor retarding properties. With the exception of the polyethylene films, all the perforated housewraps are further coated with either polyethylene or polypropylene for added air infiltration resistance. In contrast, nonperforated housewraps are either spun bonded polyethylene or fiber-mesh-reinforced polyolefin. The structure of these materials allows water vapor to pass through, while inhibiting air infiltration.



In addition to their primary functions as air infiltration barriers and water vapor transmitters, some (but not all) of the major housewrap brands are code approved as substitutes for required moisture protection barriers. To gain national code approval as a substitute for No. 15 felt, the product manufacturer must apply to each of the three major model building codes, or CABO, and supply specific testing data on water penetration resistance. With code recognition, the product can be used under all siding applications, including stucco and masonry veneer. Currently, at least four products are listed by all three model codes as acceptable moisture protection barriers: Amowrap, Pinkwrap, R-Wrap, and Tyvek. Tyvek also produces a product, StuccoWrap™, that is specifically intended for use with traditional and synthetic stucco, and is code listed for that application. Other housewraps are acceptable to some codes as weather resistant barriers. Before using a particular product as a weather barrier, its approval should be verified with the governing code.

In addition to air leakage resistance, permeance, and moisture resistance, two other material characteristics are worth considering: UV sunlight resistance, and strength. All major housewrap brands have a manufacturer's rated UV exposure time ranging from 120 days to more than 1 year. Some products are manufactured with antioxidants and UV stabilizers, while others are naturally more resistant by their composition. In the field, however, covering the housewrap as quickly as practicable is recommended, as some UV degradation will occur even over a short period, and other unrelated damage to the membrane can be avoided.

Strength of the housewrap can be critical, as wind conditions or adverse job site handling can tear or puncture the material during and after installation. Even small holes can negatively affect overall performance. The inherent strengths of housewrap can be judged on three levels: tensile strength, tear strength, and burst strength. Respectively, these are the material's ability to withstand damage from pulling and stretching; withstand tearing at nail and staple locations; and to withstand separation of material fibers, fabrics, or films. Unfortunately, testing procedures and standards vary between manufacturers, so product comparison is difficult. Generally, the spun bonded products have good tensile and burst strength but tear easily; woven and fiber-reinforced have good tear and burst strength, but are susceptible to diagonal tensile loading; laminated film products tend to be weakest of all and can lose strength significantly, making a tight installation more difficult.

Although the wide variety of housewrap products with varying performance characteristics may appear confusing, they offer a wide selection for any particular job. In northern heating climates, where interior vapor barriers are the norm, a highly moisture vapor permeable housewrap may be required. In hot, humid, cooling climates, where an interior vapor barrier is not required, a housewrap with a low air leakage rate may be preferred. In low-wind environments, a low-strength material may be selected. A particularly cost-conscious choice would be laminated film.

## **TECHNIQUES, MATERIALS, TOOLS**

### **INSTALL HOUSEWRAP OVER NEW OR EXISTING SHEATHING.**

For rehab applications, housewraps will generally be placed over existing solid board sheathing, plywood, or OSB, or over new plywood or OSB where the existing sheathing needs replacement. Housewraps come in rolls of varying widths, with 9 feet being the standard. Other widths are available, depending on the manufacturer, including 1 foot 6 inches, 3 feet, and 4 feet 6 inches. Roll lengths vary from 60 to 200 feet. Some custom sizes and lengths are available. Material thickness varies somewhat, but is irrelevant in terms of application. Beginning at an outside corner, hold the roll of housewrap vertically and unroll the material across the face of the sheathing for a short distance. Make sure the roll remains plumb and that the bottom edge of the housewrap extends over the foundation by two inches. The application should start at an outside corner extending around the starting point corner by six inches (Fig. 2).

Manufacturers specify acceptable fasteners, typically large head nails, nails with plastic washers, or large crown staples. Fastener edge and field spacing patterns are also specified. Housewrap sheets are installed shingle-style, from the bottom up. Horizontal laps should be a minimum of 2 inches; vertical laps of 6 inches are acceptable (Fig. 3). To be fully effective in their primary role as air infiltration barriers, all

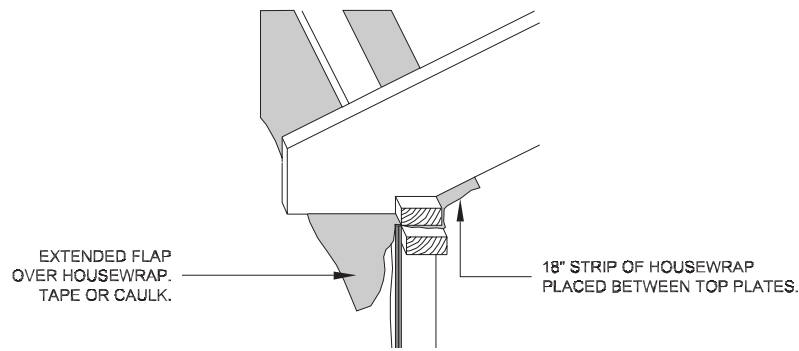

FIGURE 2

### HEAD LAP

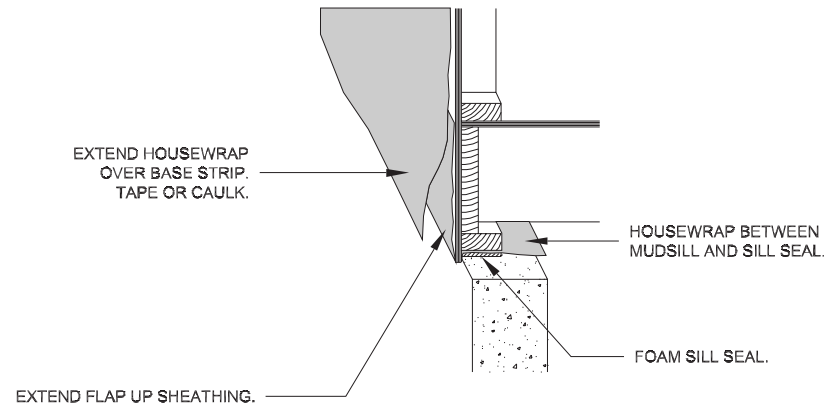

FIGURE 3

### SILL LAP

seams and edges must be taped or caulked. While some manufacturers market products for this purpose, others provide information outlining the performance requirements for approved products.

**ADVANTAGES:** Relatively low cost, lightweight, easily installed energy conservation and moisture control product. Especially effective in mixed and northern heating climates where unchecked air infiltration can significantly degrade house energy performance and occupant comfort. Beneficial in limiting airborne moisture vapor transmission into the wall cavity by limiting air movement, while allowing moisture in the cavity to be expelled. Some products can be used as a code-approved substitute for building felt.

**DISADVANTAGES:** Slightly more in initial cost than building felt. Availability of some products may be limited. Inferior performance as a weather barrier compared with building felt. Nail penetrations in housewrap are not self-sealing, as they tend to be in felts. Housewraps are not selective vapor permeable membranes: moisture vapor will pass through in both directions. As water-absorptive siding materials such as wood and brick veneer dry, moisture in vapor form can be forced through housewrap into sheathing and insulation. Less vapor-permeable building felt can better withstand reverse vapor migration. Some recent studies appear to indicate that surfactants, a class of substances found in wood, stucco, soap and detergents, can decrease the natural surface tension of water and allow it to pass through housewraps wetting the underlying materials. According to anecdotal field observations, this process is most likely to occur in regions with heavy rainfall and when unprimed wood siding is placed in direct contact with the housewrap.

## FURTHER READING

“Can Moisture Beat Housewrap?”, Ted Cushman, Ed., *Journal of Light Construction*, June 1997, p. 9.

“Sizing Up Housewraps,” Bruce Greenlaw, *Fine Homebuilding*, October/November 1994, No. 91, p. 42.

“Housewrap Manufacturers Prescribe New Details for Windows and Doors,” *Energy Design Update*, August 1998.

“Housewraps or Building Paper? No Perfect Answer,” *Energy Design Update*, July 1998.

“Housewrap vs. Felt,” Paul Fishett, *Journal of Light Construction*, November 1998.

## **PRODUCT INFORMATION**

The Celotex Corp., P.O. Box 31602, Tampa, FL 33631; 800–CELOFAX (Tuff Wrap).

DuPont, P.O. Box 80705, Wilmington, DE 19880–0705; 800–44–TYVEK (Tyvek Homewrap).

Owens Corning, Fiberglass Tower, Toledo, OH 43659; 800–GET–PINK (Pinkwrap).

Raven Industries, P.O. Box 5107, Sioux Falls, SD 57117–5107; 800–635–3456 (Rufco Wrap).

Simplex Products Division, P.O. Box 10, Adrian, MI 49221-0010; 517–263–8881 (R-Wrap, Barricade Building Paper).



# 6

# INSULATION

## ESSENTIAL KNOWLEDGE

Insulation is one element in a tightly knit construction system intended to improve indoor comfort and reduce energy consumption. In rehab work, installing insulation or improving existing insulation levels will be critical in providing comfort. Insulation should never be applied without considering its effect on other aspects of construction. Some factors to consider when evaluating wall insulation are density and compressibility, air leakage, moisture control, fire safety, and wall construction in existing homes.

Each type of insulation has a density at which its R-value per inch is greatest, but reaching this density is not always cost-effective. For 3½-inch thick fiberglass batts, an R-13 batt contains 40 percent

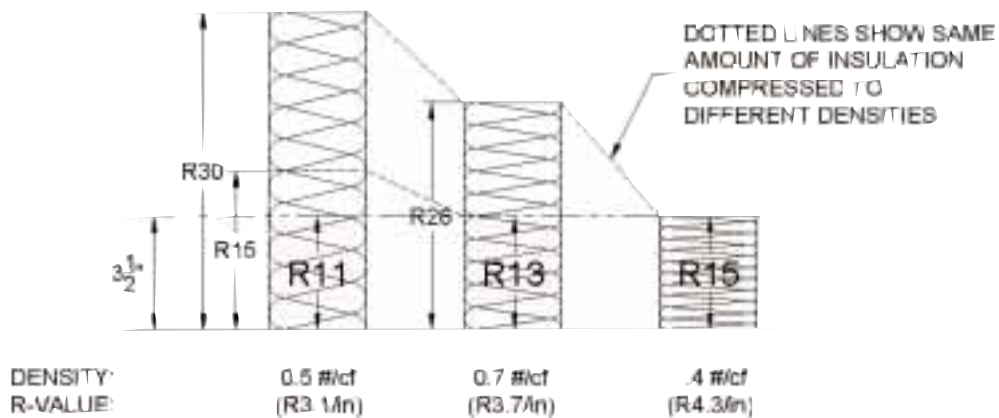

FIGURE 1

## TYPICAL FIBERGLASS BATT DENSITIES AND VALUES

more material, and an R-15 batt 180 percent more material, than an R-11 batt (Fig. 1).

To achieve a desired overall R-value for dry blown-in insulation, and to prevent settlement, the installed density must be above a recommended minimum. For convenience in comparing estimates or monitoring the installation, have the bidder or installer calculate the number of bags required to achieve the required density.

Unless insulation completely fills all the wall cavities, air leakage can bypass the insulation and create a risk of condensation. Reducing air leakage is an inseparable part of insulating; you should not do one without doing the other. Typical locations for air leakage through walls are at the sill, the wall plates, vertical corners, around openings, and at electrical devices.

Before filling stud cavities of older homes with blown-in or foamed-in-place retrofit insulation, explore the construction. Stud cavities are often interrupted by blocking half-way up the wall, or in girt-frame construction, by full-depth diagonal corner braces. The outside walls may be “back-plastered,” where a hidden layer of plaster creates two parallel cavities within each stud space, neither deep enough to receive loose-fill insulation. After insulating, an infrared camera scan of the wall will show cavities that have not been fully insulated.

Avoid deliberately ventilating walls, since any convective airflow within an outside wall risks condensation within the wall and compromises its R-value. Ventilation passages behind the exterior finish are called for when extreme interior humidity is expected and no vapor retarder can be applied, or where wood siding is applied directly over exterior foam insulation.

## TECHNIQUES, MATERIALS, TOOLS

Of the innumerable possible combinations of insulating materials and wall configuration, the following list covers those in common use and uncommon systems that are recommended.

### 1. INSTALL BATT INSULATION.

Fiberglass insulation is available in batt form, typically sized 93 inches long to fit within the stud-space of an 8-foot wall, or in continuous rolls. Both forms are here referred to as “batt insulation.” It is available in many thicknesses, densities and in widths to fit framing at 16-inch and 24-inch centers. Unfaced batts can easily be cut to fit into odd-sized spaces, and are preferred where a continuous membrane vapor retarder is installed. Residential batts are available faced with kraft-paper and aluminum foil, and commercial batts with a flame-resistant foil facing are available. All have extended tabs on the facings to secure them in place. When properly applied, the facings create a partial vapor retarder. Only unfaced or fire-retardant-faced batts can be left exposed in attics or occupied spaces. If not accurately cut around wiring and other obstacles, faced batts create large air cavities that compromise their effectiveness. Tabs can be “inset stapled” to the sides of the studs, or “face stapled” to the inner face (Fig. 2). Face stapling is preferred because it creates a better vapor retarder and avoids the air cavity left between the facing and the wall finish when inset stapling. Unless this cavity is carefully sealed at the top and bottom, it can compromise the wall’s air-tightness and R-value. Staples into stud faces must be fully set to avoid interfering with drywall installation. In a three-sided wall cavity, friction-fit unfaced batts, covered with a separate vapor retarder, will typically result in a more effective installation than will stapled faced batts. In an open wall, the facings are usually necessary for attachment.

**ADVANTAGES:** An economical, flexible, and well-known product. Provides a dependable thickness of uniform density and does not settle, if properly installed. Faced batts can insulate an open stud wall.

**DISADVANTAGES:** Effectiveness requires careful installation to avoid gaps and consequent convective losses. Glass fibers can be irritating if touched or inhaled.

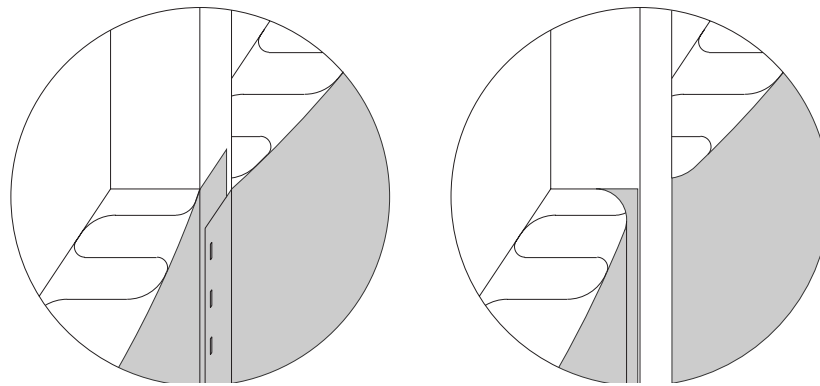

FIGURE 2

FACE STAPLED

INSET STAPLED

### 2. INSTALL ENCAPSULATED FIBERGLASS INSULATION.

Fiberglass insulation is available in rolls or batts, encapsulated with kraft paper or plastic to reduce mechanical irritation to installers. These can be used in any installation where batts are appropriate. One face is extended to form attachment tabs. The faces on sound control batts do not have a vapor retarder; and some exterior wall batts have a polyethylene vapor retarder on the flange side. Some encapsulated batts have a Class A fire-rating and can be left exposed if allowed by local codes. Owens Corning markets Miraflex, made from loose, virtually itch-free glass fibers with no binder, contained in a plastic sleeve. Cutting encapsulated batts around obstructions is possible, but exposes the fiberglass. Cutting Miraflex releases the fibers; the product

is therefore intended primarily as attic floor insulation.

**ADVANTAGES:** deal for rehab contractors. Can be left exposed (check local codes). Flange-attached with or without a vapor retarder on some products.

**DISADVANTAGES:** More costly than regular batt insulation. Cutting encapsulated batts exposes the fiberglass, and cutting Miraflex releases the fibers.

### **3. INSTALL BLOWN-IN LOOSE-FILL INSULATION INTO CLOSED STUD SPACES.**

Loose-fill insulation (fiberglass, cellulose, or mineral wool) can be blown into closed stud spaces through openings formed by drilling holes through the interior or exterior finish, or by removing strips of interior or exterior finish, at the top and bottom of each rafter space. Careful installation is required because material can bridge over electric lines and other obstructions, causing voids and later settlement. Beware of blocking; blow into cavities above and below it. At least a moderate amount of pressure is required to produce sufficient density to inhibit settlement. Fiberglass blown into a 2 by 4 stud cavity at a density of about 1.5 pcf produces R-13 without excess pressure on finishes. In a “dense-pack” installation of cellulose, dry material is applied at high velocity through a narrow tube inserted through a single hole at the top and extended to the bottom of the cavity. The tube is gradually withdrawn, compacting the material to a density of 3 to 3½ pcf. “Stabilized” cellulose includes an adhesive, and “Fiberized™” cellulose is made in strands instead of chunks; both processes are claimed to inhibit or prevent settlement. Insulation packed into and filling wall cavities suppresses air movement within the cavity, does not create a vapor retarder, but may substantially improve fire safety.

**ADVANTAGES:** If the cavities are completely filled under sufficient pressure, provides superior insulating performance without settlement, greatly reducing air circulation within the walls, and may improve fire safety.

**DISADVANTAGES:** Some types of installation may leave voids and/or settle after installation. Blown-in materials do not form a vapor retarder, and form only a partial air barrier.

### **4. INSTALL BLOWN-IN OR SPRAYED-ON INSULATION INTO OPEN STUD SPACES.**

An inexpensive material can be applied as a membrane over open studs to form “see-through” cavities, within which any blown-in insulation can be applied under moderate pressure. In Ark-Seal’s Blown-in-Blanket® (BIBS) system, fiberglass mixed with some water and adhesive is blown through slits cut in a tightly stretched nylon netting. In Par-Pac’s Dry-Pac Wall System™, dry cellulose is blown at 3 pcf density into a cavity closed by a reinforced polyethylene vapor retarder (Fig. 3). The material is installed from the



FIGURE 3

#### **BIBS SYSTEM**

bottom up to minimize voids and settlement. All such installations will cause the membrane to bulge out; make sure this bellying does not interfere with drywall installation. Various types of polyurethane- and polyisocyanurate-based insulations, such as Icynene, can also be spray-applied into stud cavities. A thin layer of such material can form an air-barrier skin, over which cheaper material can be placed. Excess

material must be scraped off, and windows and electrical devices protected or cleaned. Water is mixed with cellulose in a “wet-spray” application. The water combines with the starch in the cellulose to form a natural adhesive, which holds the material in place. Excess material must be scraped off, but can be reused. The material must dry out before a finish is applied; excessive water can prevent drying and generate rot or mildew. High-density insulation filling cavities may improve fire safety.

**ADVANTAGES:** Fills the cavities without settling. Visual inspection is possible to insure filled cavities. Greatly reduces air circulation within walls. May improve fire safety.

**DISADVANTAGES:** Bellying of the interior membrane may interfere with drywall installation. Sprayed-on foam products are more expensive than batt or loose-fill installations, and are messy processes, requiring cleanup and protection. Excess water in wet-spray applications may lead to rot and mildew.

## **5. INSTALL RIGID WALL INSULATION.**

A 3/4-inch to 1-inch layer of rigid insulation, typically polyisocyanurate (ISO), molded expanded polystyrene (EPS), or extruded polystyrene (EPS), is a widely used adjunct to cavity insulation. Where cavity insulation cannot be installed, rigid foam may be the only way to insulate a wall. It is preferably applied on the outside of the framing, keeping the framing warm enough in cold weather to prevent condensation within the walls, and inhibiting thermal short-circuits through the studs. It is also useful on the outside as a base for cement stucco or exterior insulation and finish systems (EIFS), although the latter should be part of an engineered system that provides interior drainage. A layer of foam is essential in conjunction with conventional steel framing to prevent surface condensation. In Gulf-coast climates, a layer of foam behind the interior finish is preferred over an exterior layer or a layer on both sides of the studs, especially with steel framing. Since foam cannot be relied upon to resist racking, it must be applied over structural sheathing or in parallel with a system of wall shear bracing. Structural sheathing separated from the framing by an outside layer of foam may not meet code racking requirements (consult with a structural engineer). Celotex makes a structural polyisocyanurate foam sheathing that, when glued and nailed to the framing, acts as racking bracing. Wood siding should not be applied directly to foam insulation.

**ADVANTAGES:** Isolates framing to minimize or eliminate internal condensation and reduce cold bridging through framing. Can add more than its rated R-value to a wall assembly.

**DISADVANTAGES:** More costly per R than fiberglass insulation. If substituted for exterior sheathing, requires other measures to create racking resistance in the structure. Should not be used with EIFS except as part of an engineered system with interior drainage. EPS cannot support one-coat cement stucco over more than 16" stud spacing.

## **6. INSTALL A RADIANT BARRIER.**

While radiant barriers and coatings are commonplace in high-temperature industrial applications (typically 500° F or more), they are marginally effective at ordinary temperatures. To be cost-effective in building applications, they must have a very low incremental cost (from 2 to 10 cents/sf, depending on the application). Clean, shiny aluminum foil facing a 3/4 inch or deeper air space can create a radiant barrier. Foil-faced insulation held back and inset-stapled creates only a marginally effective radiant barrier because the insulation bulges into the air space, and because the cavity can create heat loss through convection: it is always more effective to fill the cavity with insulation. If an air space is present for other reasons (for example, the cavity between sheathing and brick veneer), facing the air space with foil-faced sheathing will add thermal resistance if the material remains clean. A new form of radiant barrier is Radiance™ paint, which contains aluminum dust.

**ADVANTAGES:** An easy way to add insulating value at brick cavity walls.

**DISADVANTAGES:** Marginally cost-effective; unlikely to be effective if exposed to dirt or condensation. Not cost-effective in cold climates, except possibly Radiance™ paint. Seldom or never cost-effective if the air space is deliberately “stolen” from conventional insulation. Foil may create a vapor barrier where one is not desired.

## **7. INSTALL A STRUCTURAL INSULATED PANEL WALL.**

Rigid foam insulation adhered to structural skins can create a structural insulated panel (SIP). SIPs provide a combination of structure and insulation. Depending upon the design, the panels may be

self-supporting or may be a non-load-bearing exterior skin applied over a post and beam frame. Very tight joints are crucial, since a small amount of air leakage through a joint is guaranteed to create destructive condensation at the most critical structural point. Panels are typically fabricated to order and delivered to the site for quick erection. Acoustical tightness is readily noticeable.

**ADVANTAGES:** A high-R wall that can be load bearing and resists racking. Provides excellent acoustical resistance. Allows a high level of prefabrication and fast on-site erection.

**DISADVANTAGES:** Not yet in common use, and therefore more expensive than ordinary framing. Requires careful air-sealing at all joints.

## FURTHER READING

*ASHRAE, 1997 Handbook of Fundamentals*, Inch-Pound Edition, Chapter 22: Thermal and Moisture Control in Insulated Assemblies—Fundamentals; Chapter 23: Thermal and Moisture Control in Insulated Assemblies—Applications; Chapter 24: Thermal and Water Vapor Transmission Data, American Society of Heating, Refrigerating and Air-Conditioning Engineers, Inc., Atlanta, GA; 404-636-8400; [www.ashrae.org](http://www.ashrae.org).

“Fiberglass vs. Cellulose: Making the Choice,” Ted Cushman, *Journal of Light Construction*, Sept. 1995, pp 27–31.

Energy Source® Catalog; Iris Communications, Inc.; 800-346-0104.

Energy Star Fact Sheets; Builder Guides; U.S. Environmental Protection Agency (EPA), Atmospheric Pollution Prevention Division; 888-STAR-YES.

Home Energy’s Consumer Guide to Insulation; [www.homeenergy.org/eehem/96/9609insulation.html](http://www.homeenergy.org/eehem/96/9609insulation.html).

Residential Energy Efficiency Database (REED); <http://139.142.36.88/reed/index.htm>.

Sawnee Energy Library; [/www.energydepot.com/sawnee/library/library.cfm](http://www.energydepot.com/sawnee/library/library.cfm).

U.S. Department of Energy (DOE) Energy Efficiency and Renewable Energy Clearing House (EREC); 800-363-3732; e-mail: [doe.erec@nclinc.com](mailto:doe.erec@nclinc.com); <http://erecbbs.nclinc.com>.

“Insulation Fact Sheet,” August 1997, Document DOE/CE-0180.

“Loose-Fill Insulations,” May, 1995, Document DOE/GO-10095-060.

“Insulation Materials: Environmental Comparisons,” Alex Wilson, *Environmental Building News*, Volume 4, Number 1, January/February 1995.

“Insulation Comes of Age,” Alex Wilson, *Fine Homebuilding*, February/March 1996, No. 100.

## PRODUCT INFORMATION

### BATT, SPRAY-ON, AND LOOSE-FILL INSULATION

Cellulose Insulation Manufacturers Association, 136 South Keowee Street, Dayton, OH 45402; 937-222-2462; [www.cellulose.org](http://www.cellulose.org).

American Rockwool, Inc., P.O. Box 880, Spring Hope, NC 27882; 919-478-5111.

Ark-Seal International, 2190 South Kalamath, Denver, CO 80223; 800-525-8992.

Building Products Division, The Celotex Corporation, P.O. Box 31602, Tampa, FL 33631; 813-873-4000.

CertainTeed Corporation, 750 East Swedesford Road, Valley Forge, PA 19482; 800-523-7844.

GreenStone Industries Inc., 6500 Rock Spring Drive, Suite 400, Bethesda, MD 20817; 888-592-7684.

Icynene Inc., 376 Watline Avenue, Mississauga, ON L4Z 1X2, Canada; 800-946-7325.

International Cellulose Corp., 12315 Robin Boulevard, Houston, TX 77245-0006; 800-444-1252.

Johns Manville Corporation (formerly Schuller International Inc.), 717 17th Street, Denver, CO 80202; or P.O. Box 5108, Denver, CO 80217-5108; 800-654-3103.

Knauf Fiber Glass, 240 Elizabeth Street, Shelbyville, IN 46176; 800-200-0802.

Owens Corning, One Owens Corning Parkway, Toledo, OH 43659; 800-354-PINK or 800-GET-PINK.

Par-Pac™, 4545 East 52nd Avenue, Commerce City, CO 80022; 800-850-8505.

Rock Wool Manufacturing Co., 203 North Seventh Street, Leeds, AL 35094; 205-699-6121.

Sloss Industries Corporation, 3500 35th Avenue North, Birmingham, AL 35207; 205-808-7803.

U.S. Fiber, Inc., 905 East Martin Luther King Dr., Suite 400, Tarpon Springs, FL 34689; 800-666-4824.

Western Fiberglass Group, 6955 Union Park Center, Suite 580, Midvale, UT 84047; 801-562-9558.

## STRUCTURAL INSULATED PANELS

Structural Insulated Panel Association, 1331 H Street NW, Suite 1000, Washington D.C. 20005; 202-347-7800; e-mail: sipadc@aol.com.

## RIGID FOAM INSULATION

Expanded Polystyrene Molders Association (EPSMA), 1926 Waukegan Road, Suite 1, Glenview, IL 60025-1770; 800-607-3772.

Polyisocyanurate Insulation Manufacturer's Association (PIMA), 1001 Pennsylvania Avenue, N.W., 5th Floor, Washington, DC 20004; 202-624-2709; www.pima.org.

Celotex Building Products, P.O. Box 31602, Tampa, FL 33631-3602; 813-873-4230.

Dow Chemical Company, Styrofoam Brand Products, 2020 Willard H. Dow Center, Midland, MI 48674; 800-258-2436.

Johns Manville Corporation (formerly Schuller International Inc.), 717 17th Street, Denver, CO 80202; or P.O. Box 5108, Denver, CO 80217-5108; 800-654-3103.

Owens Corning, One Owens Corning Parkway, Toledo, OH 43659; 800-354-PINK or 800-GET-PINK.

Tenneco Building Products, 2907 Log Cabin Dr., Smyrna, GA 30080; 800-241-4402.

## RADIANT BARRIER PRODUCTS

Energy-Brace™ reflective sheathing, Fiber-Lam, Inc., P.O. Box 2002, Doswell, VA 23047; 804-876-3135.

Radiance™ Low-e interior paint, ChemRex, 889 Valley Park Drive, Shakopee, MN 55379; 800-433-9517.

Thermo-ply™ reflective sheathing, Simplex Products Division, P.O. Box 10, Adrian, MI 49221; 517-263-8881.



## ESSENTIAL KNOWLEDGE

Introduced in the 1960s, vinyl siding has become the leading wall cladding material for siding (60 to 70 percent of the national residing market, and 40 to 50 percent of the national new siding market). Regionally, its most prevalent use is east of the Mississippi. Originally considered a relatively low-performing product that had fading and cold-weather cracking problems, vinyl siding has evolved into a high performing product with good weatherability and a level of detailing and finish that, in the most sophisticated and innovative examples, comes fairly close in appearance to the wood siding products that it emulates. It is essential, however, that vinyl siding be allowed to expand and contract freely. It is estimated that over 90 percent of the problems with vinyl siding are caused by a lack of sufficient clearance between the nail head and the nailing slot or between the siding and trim.

Vinyl siding is made of polyvinyl chloride (PVC) resins with inorganic color pigments, Ultraviolet (UV) stabilizers, and various plasticizers. It has a typical exposure of 8 or 10 inches plus a fastening tab (hem), and is commonly available in 12 foot lengths, although longer lengths are available from some manufacturers. Physical characteristics are established by American Society for Testing Materials (ASTM) D3679, which sets minimum thickness at 0.035-inch. Thickness is not the only indicator of performance. The specific PVC formulation, siding profile, and attachment details are also important characteristics. The industry is reviewing ways to set multiple performance requirements, but at this time siding thickness is the primary means of differentiating products.

There are three general classifications for vinyl siding based on thickness, with sub-classifications for low and high-end products:

TABLE 1

| <b>Super Economy</b>  | <b>Economy</b>        | <b>Standard</b>       | <b>Premium</b>        | <b>Super Premium</b> |
|-----------------------|-----------------------|-----------------------|-----------------------|----------------------|
| 0.035" to<br>< 0.040" | 0.040" to<br>< 0.042" | 0.042" to<br>< 0.044" | 0.044" to<br>< 0.048" | 0.048" +             |

Prices vary accordingly, with some super premium products costing up to twice the cost of super economy. Most of the material sold is in the economy range. Industry consensus holds that material below 0.040 inch may be too thin to conceal uneven substrates. The super premium products, at 40 percent thicker, will not necessarily last 40 percent longer than standard products, although they will be straighter, less wavy, more resistant to impact damage, and may be architecturally more distinctive. Most vinyl siding is sold as a "commodity" product, in standard economy styles and finishes. However, some fairly recent evolutions/innovations in vinyl siding have been introduced largely in higher-end products. Many of these reflect small niche markets today, but the market is becoming more selective and quality conscious:

■ **Product formulations:** Most manufacturers have continued to refine existing formulas to develop better weathering and non-fading characteristics. Non-fading warranties have been introduced that extend the warranty period. New premium resins are being developed that will allow darker colored panels to perform as well as lighter ones.

■ **Finishes:** A number of manufacturers have developed low gloss finishes that replicate sanded, sealed, and painted cedar. Some closely resemble the texture of cedar clapboard and the color of stained siding. Simulated plain and scalloped cedar shingles and decorative cedar panels, such as Certainteed's Cedar Impressions™, made from polypropylene, are also available. Extended warranties are available against peeling, blistering, rotting, flaking, chipping, cracking, corroding, and excessive fading.



■ Profiles and reinforcements: High-end products, such as Wolverine's Super Premium Portfolio HP™, provide thicknesses up to 0.055 inch, deeper reveals, reinforced nailing hems, and stronger locking profiles. Wolverine offers a fiberglass reinforcement bar in its Benchmark™ series that overlaps adjacent panels and provides increased rigidity. Wolverine has recently developed a flexible nail hem on its Millennium™ series that eliminates the conventional slotted hem, making fastening faster and simpler, reducing expansion and contraction problems, and allowing the use of stapling as well as nailing. Certainteed, Heartland, and Alside also have developed reinforced interlocks (Fig. 1).

■ Insulated siding products: Progressive Foam Products manufactures an insulated contoured underlayment, ThermoWall®, that is designed to go over existing siding products, provide a rigid base for new vinyl siding and add an R-value of up to 4.2 to the existing wall. The underlayment panels (Fig. 2), 20 inches high, 48 inches long, and minimum 1/2 inch thick, are profile-specific and have been developed for over



WOLVERINE® MILLENNIUM™ SIDING

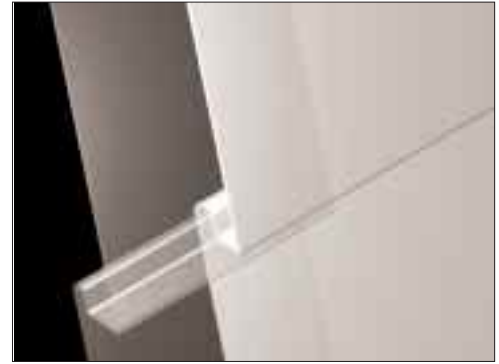

ALSIDE CENTERLOCK™



BENCHMARK™ LAPLOCK™

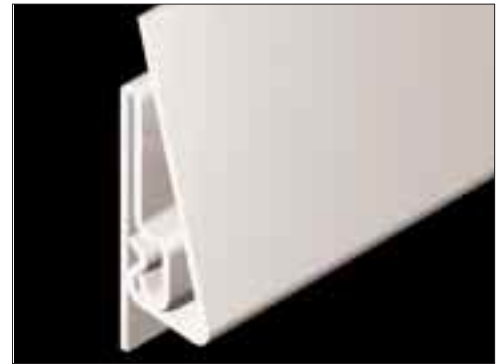

CERTAINTEED CERTILOCK™

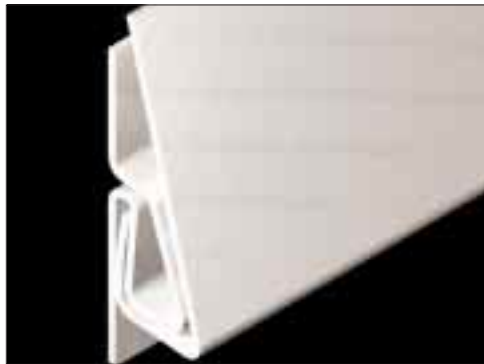

WOLVERINE® GRIPLOCK™

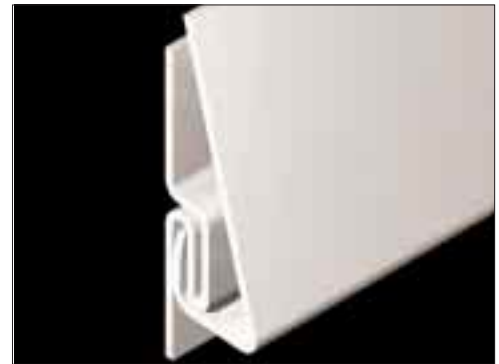

STANDARD VINYL SIDINGS

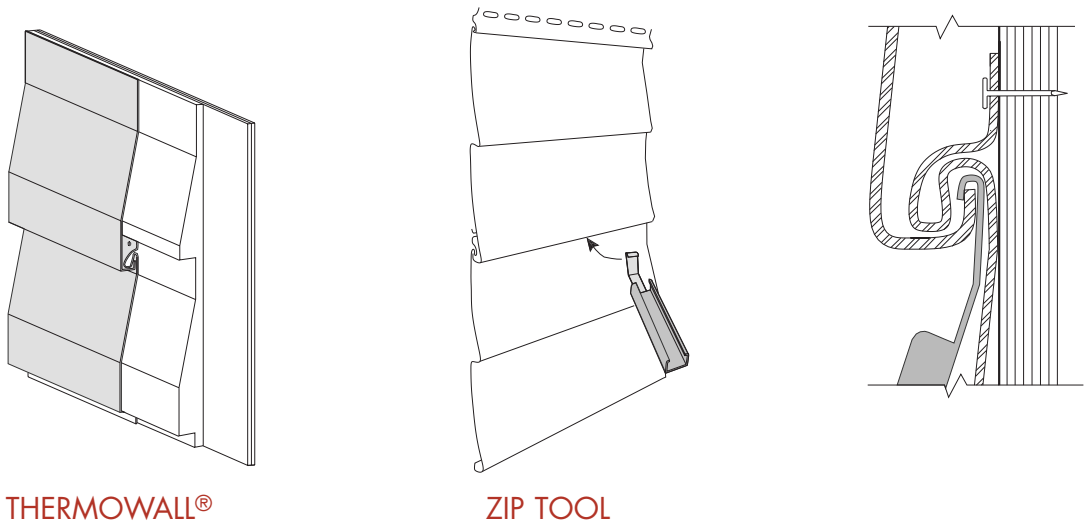

FIGURE 2, 3

THERMOWALL®

ZIP TOOL

750 existing vinyl siding products from different manufacturers. Progressive has helped develop a four-course profile for VIPCO (a division of Crane Plastics) that is laminated to a vinyl siding panel approximately 12 feet long by 16 inches high, sold under the name of TechWall™.

■ Trim and accessory panels: A number of manufacturers produce wide window, door, and corner trim with reveals that eliminate the standard J channel and make the joining of material appear closer to that of wood siding. Note that siding cannot be butted directly against wood trim without use of a J channel. Vinyl siding requires trim on outside and inside corners.

## TECHNIQUES, MATERIALS, TOOLS

### 1. REMOVE STAINS FROM EXISTING VINYL SIDING.

Some vinyl siding, which might appear to need replacement, can be rehabilitated by careful cleaning. Vinyl siding will fade over time, but maintenance and cleaning will prolong the service life and appearance of the material. Vinyl siding is easily cleaned with a variety of approved cleaners that are formulated for specific staining problems. The Vinyl Siding Institute has prepared a comprehensive list of those cleaners that will remove most stains (see Further Reading).

ADVANTAGES: A low-cost approach to vinyl siding rehab.

DISADVANTAGES: Cleaning might not eliminate all staining and will not eliminate fading.

### 2. REPAIR EXISTING VINYL SIDING.

Sections of vinyl siding that are buckled, dented, cracked, stained, or otherwise damaged can be easily replaced by means of a “Zip” tool that slips behind the bottom of the siding panel above the damaged panel, allowing access to the damaged panel for replacement (Fig. 3). Instructions are provided by the Vinyl Siding Institute and individual manufacturers (see Further Reading).

ADVANTAGES: Allows portions of vinyl siding to be replaced without complete residing.

DISADVANTAGES: New vinyl replacement siding will not match weathered vinyl siding. Small discolored sections can be painted with an all-acrylic paint, although the Vinyl Siding Institute does not specifically endorse painting.

### 3. REPLACE/COVER EXISTING SIDING WITH NEW VINYL SIDING.

Existing siding can be prepared in three ways:

1. Strip off existing siding that has deteriorated to the point where it cannot be used as a substrate. This will assure the straightest and flattest application and will allow inspection of the sheathing and

insulation, which can be replaced if necessary. Install new vinyl siding as per manufacturer's installation requirements. Note that vinyl siding requires a smooth, even, rigid substrate such as plywood, wood composition, rigid foam insulation, or fiber sheathing. It cannot be installed directly to structural framing or it will sag and deflect between framing members. (Failure to establish a smooth solid substrate may constitute a misapplication under the terms of the warranty.)

2. Apply rigid or semi-rigid (e.g. FoamCore™ by International Paper) sheathing to existing siding to provide a smooth substrate. Nail securely through old siding and into framing members. Flash as necessary around projections and openings.

3. Apply vertical furring strips to old siding to strengthen and straighten uneven surfaces. Then apply rigid sheathing as described in example 1 above. Vinyl siding cannot be applied directly over furring. Residing over existing material will require jamb and trim extensions.

Vinyl siding should be applied with corrosion resistant nails (aluminum or galvanized) with a minimum  $\frac{3}{4}$  inch penetration into wood or wood composition substrate. When foam sheathing is used directly over studs, nails must penetrate studs by at least  $\frac{3}{4}$  inch. Nails should be driven so that the heads are  $\frac{1}{16}$  to  $\frac{1}{8}$  inch away from the slotted nailing tab to allow for shingle movement. Pneumatic staplers or nailers can be used but can bind siding more easily (especially staples) than hand nailing, unless used by an experienced installer. Individual manufacturers' installation guidelines should be followed carefully.

**ADVANTAGES:** Better quality vinyl siding replicates wood siding appearance. New formulations, textures, colors, and details are now available that allow more choice and improve the appearance of most architectural styles. A relatively low maintenance product.

**DISADVANTAGES:** Vinyl siding, especially the thinner products, might appear wavy and will reflect the irregularity of some substrates. Expands and contracts more than other siding materials. Thinner gages are susceptible to "oil canning" and may become brittle over time. Overdriven or improperly placed fasteners can resist siding movement and cause buckling. Colors, especially dark ones, will fade over extended periods. Vinyl siding is not weatherproof and requires a weather barrier.

## **FURTHER READING**

"Application Instructions," Vinyl Siding Institute, the Society of Plastics Industry Inc., 1994.

"Cleaning of Vinyl Siding," Vinyl Siding Institute, the Society of Plastics Industry Inc., 1994.

"Fire Properties," Vinyl Siding Institute, the Society of Plastics Industry Inc., 1994.

"Installation Guide for Vinyl Siding and Accessories," Wolverine/Certainteed, 1998; 888-838-8100; [www.vinylsiding.com](http://www.vinylsiding.com).

"Vinyl Siding," George Schamback, *The Journal of Light Construction*, June 1997, pp. 27-31.

## **PRODUCT INFORMATION**

Vinyl Siding Institute, 1801 K Street, Suite 600K, Washington, DC 20006; 888-FORVSI-1; [www.vinylsiding.org](http://www.vinylsiding.org). (A complete list of member companies, their web sites and products, can be obtained from the Vinyl Siding Institute.)

Progressive Foam Products, Beach City, Ohio; 800-860-3636; [www.progressivefoam.com](http://www.progressivefoam.com).

TechWall™-VIPCO, 1441 Universal Drive, Columbus, OH 43216; 800-366-8472; [www.crane-plastics.com](http://www.crane-plastics.com).

Foam-Core™-International Paper, P.O. Box 1839, Statesville, NC 08687-1839; 800-438-1701; [www.ipaper.com](http://www.ipaper.com).

# 8

# METAL SIDING

## ESSENTIAL KNOWLEDGE

Aluminum and steel siding gained great popularity in the 1950s and 1960s as the most durable and cost-effective materials for replacing or covering up old, deteriorating siding. It frequently contained thin foam inserts which, manufacturers claimed, greatly enhanced the insulating qualities of the material. While the new siding may have been effective in reducing air infiltration, the thinness of the insulation and the great thermal conductivity of metal made this siding a poor performer in terms of energy.

The use of aluminum and steel siding has drastically declined in recent years with the emergence and popularity of vinyl and fiber cement siding products, to the point where metal siding now accounts for only about 1 percent of the new siding market. Primary markets include the Midwest (particularly for steel siding) where cladding must resist hailstorms and temperature extremes. In metropolitan areas where local codes require noncombustible building materials, metal siding is an obvious choice. The plethora of existing metal siding makes it a prime candidate for repair or replacement in rehab work.

## TECHNIQUES, MATERIALS, TOOLS

### 1. MAINTAIN METAL SIDING.

Under normal conditions, metal siding will require only occasional washdown with a garden hose and a soft bristle brush. If the siding is moderately dirty, use a solution of  $\frac{1}{3}$  cup of a mild clothwashing detergent to a gallon of water. For heavier dirt and stains the non-abrasive detergent can be mixed with  $\frac{2}{3}$  cup trisodium phosphate (Soilax, or Spic-N-Span for example) to a gallon of water. Use mineral spirits to remove caulking compounds, tar and similar substances. Clean from bottom to the top. Rinse thoroughly. Avoid abrasive cleaners and strong solvents.

ADVANTAGES: Maintenance is simple and effective.

DISADVANTAGES: Will not remove fading and severe caulking.

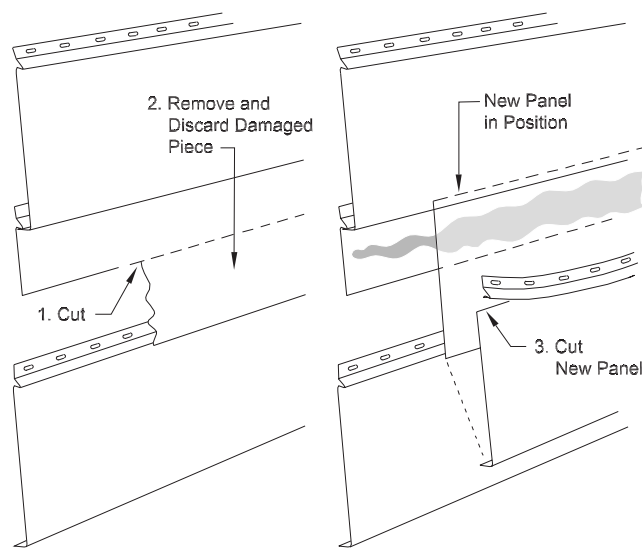

FIGURE 1

REPLACEMENT OF SIDING



FIGURE 2

## ON-SITE ROLL FORMING

### 2. REPAIR METAL SIDING.

The replacement of metal panels is relatively simple: 1. Cut the damaged panel along its center with a utility knife or metal shears. Remove and discard the bottom section; 2. Cut and remove the top lock or a new panel; 3. Apply a heavy bead of Gutterseal (Alcoa or other brand) the full length of the defective panel; 4. Install the new panel over the Gutterseal. Apply pressure with the palm of the hand. Do not nail the panel. (Fig. 1)

ADVANTAGES: Repair is relatively simple procedure.

DISADVANTAGES: Color of replacement will not match original.

### 3. REPLACE EXISTING SIDING WITH STEEL SIDING.

Considered by some in the industry to be one of the highest performing siding products on the market because of its resistance to cracking, bending, high winds, and high temperatures, steel continues to have a strong niche market. Steel can be placed directly over existing siding materials, over insulated sheathing on top of existing material, or attached to furring strips placed on masonry or uneven walls. It typically comes in 12-foot lengths and panel widths of double 4 or 5-inch exposures, with a PVC or acrylic finish. A number of companies, such as ABC Seamless, provide seamless steel siding through franchised installers. It is roll-formed on site to eliminate vertical joints (Fig. 2).

ADVANTAGES: One of the strongest and most damage-resistant siding products available; lays flat and straight against most substrates; color finishes warranted against fading and peeling; noncombustible; can be touched up with paint.

DISADVANTAGES: Approximately double the cost of standard vinyl siding; 30 percent more expensive than aluminum siding. Fewer profiles, styles, colors, trim, and accessories than vinyl siding.

### 4. REPLACE EXISTING SIDING WITH ALUMINUM SIDING.

Aluminum continues to have some niche market appeal, although its use is diminishing. Aluminum siding is typically available in 12-foot lengths and panel widths of double 4 or 5-inch exposures, with a PVC or acrylic finish. The most popular color is white, but a limited color palette is available. Like steel siding, aluminum can be applied directly over wood-sided walls that are sound and straight, over insulated siding, and over furring strips.

ADVANTAGES: Lays straight over most substrates; less likely to show waviness than vinyl siding; lightweight, noncombustible, durable, and easy to clean.

DISADVANTAGES: More costly than vinyl; dents relatively easily; comes in limited styles and colors.

## **PRODUCT INFORMATION**

ABC Seamless, 3001 Feichner Drive, Fargo, ND 58103; 701-293-5952.

Alcoa Building Products, P.O. Box 57, 1501 Michigan St., Sidney, OH 45365-0057; 800-962-6973;  
[www.alcoahomes.com](http://www.alcoahomes.com).

Alside, 373 State Road, P.O. Box 2010, Akron, OH 44309; 800-257-4335.

EDCO, 8700 Excelsior Boulevard, Hopkins, MN 55343; 800-333-2580.

Norandex/Reynolds Distribution Co., 8450 South Bedford Road, Macedonia, OH 44056; 330-468-2200;  
[www.norandex.com](http://www.norandex.com); [www.reynoldsbp.com](http://www.reynoldsbp.com).

Reynolds Building Products, One Norandex Place, Macedonia, OH 44056; 330-468-2200.

United States Seamless, Inc., 2001 First Ave. N., P.O. Box 2426, Fargo, ND 58108-2426; 701-241-8888;  
[www.usseamless.com](http://www.usseamless.com).

# WOOD SHINGLES & SHAKES

## ESSENTIAL KNOWLEDGE

Wood shingles and shakes (thicker versions of shingles) have been used for siding for more than 300 years. Today, most of this material is milled in Canada and is made of Western red cedar, Eastern white cedar, or Alaskan yellow cedar. Pressure-preservative-treated Southern yellow pine is also used for shakes on a limited, regional basis. Western red cedar weathers a darker gray than the other two materials. A few mills make redwood shingles, but they are not as popular as cedar because they weather considerably darker. Cedar shingles and shakes are warranted against material defects for a minimum of 20 years (30 if pressure-treated with CCA) by members of the Cedar Shake and Shingle Bureau (CSSB).

Western red cedar shingles are available in a variety of grades, including No. 1 BLUE LABEL (100 percent heartwood, 100 percent clear, 100 percent end grain) and No. 2 RED LABEL with some flat grain and limited sapwood. Other grades are available for secondary structures, economy installations, and undercoursing. No. 1 is the preferred grade for both roofing and siding, but No. 2 grade is also used for siding because the weathering conditions are not as extreme as roofing.

Eastern white cedar shingles (increasingly coming from small, second growth trees) are not available in 100 percent edge grain, and are graded by knot content. Grade "A" BLUE LABEL is all heartwood with no imperfections; Grade "B" RED LABEL allows imperfection such as knots on non-exposed parts and has a recommended maximum exposure of 6 inches. Grades "A" and "B" are recommended for siding. Grade "C" BLACK LABEL is an economy grade that allows sound knots on exposed portions, and has a rustic appearance. Grade "D" is a utility grade for underlayment. Eastern white cedar shingles are available prefinished from Sovebec, Inc. (Eastern Canada's largest consortium of white cedar mills) in a tailored rebuted and squared configuration with a peroxide bleaching agent and latex stain called "Ultra Bleach," which accentuates and accelerates the silver gray weathered appearance (see Product Information).

Western red cedar shakes are available in a variety of textures and finishes including: machine grooved; handsplit face and resawn back; taper sawn on both sides (resembling an extra-thick shingle); taper split by hand both sides and straight-split by machine both sides. See the *Cedar Shake and Shingle Bureau Design and Application Manual* for detailed specifications on cedar siding.

## TECHNIQUES, MATERIALS, TOOLS

### 1. REPLACE INDIVIDUAL CEDAR SHINGLES.

If a small number of individual shingles are badly curled, cracked, or missing, they can be removed and replaced relatively easily: Cut nails holding damaged shingles with a hack saw blade. Split shingles with a chisel and remove pieces. Cut a new shingle to fit with a 1/8 to 1/4 inch clearance each side.

ADVANTAGES: An inexpensive way to repair existing siding.

DISADVANTAGES: Will not work with a large area of defective shingles.

### 2. RESIDE WITH NEW CEDAR SHAKES AND SHINGLES.

Certain types of existing siding including vertical wood siding or paneling, and existing wood clapboard that are flat and in sound condition, can be left in place and new shingles applied over them. Shingles can be applied over beveled siding by filling in the low points of the wall with low grade timber strips (called



“horse feathers”) and thereby increasing the potential nailing surface, or by nailing the shingles or shakes to the high points of the bevels of each course of the old wall (Fig. 1). However, many shingle manufacturers recommend the use of furring strips or a plastic mesh product such as Cedar Breather™ be used to allow for air circulation and to reduce the potential of excessive moisture build-up behind the shingle (Fig. 2). If the existing siding is stucco or masonry, or if the surface is uneven, horizontal, or a combination of horizontal and vertical, furring is necessary to flush out the wall, allow for air circulation, and to provide a nailing surface for the new siding (Fig. 3). If the existing siding is substantially deteriorated, removal of the shingles allows for the inspection, removal, and reinstallation of existing insulation, sheathing, flashing, caulking, building paper, or housewrap as necessary. If the sheathing is nonstructural or foam, new shingles should be fastened to furring that is laid over the sheathing. Furring is typically 1 by 3 or 1 by 4 material (Fig. 4). Wherever possible, butt lines should align with tops or bottoms of windows or other openings for appearance. Shingle exposure should be consistent. Corners can be butted against corner boards or laced together on outside and inside corners, or mitered on outside corners (Fig. 5).

**ADVANTAGES:** An attractive, natural material for both traditional and contemporary buildings. Can be treated with a variety of coatings and preservatives or left to weather naturally. A sustainable material that comes from renewable sources. Residing over existing wall eliminates the time and expense of removing existing siding.

**DISADVANTAGES:** More costly than other siding material. Can weather unevenly in certain conditions. Combustible unless pressure-treated with fire retardants. Some warping and cupping will occur.

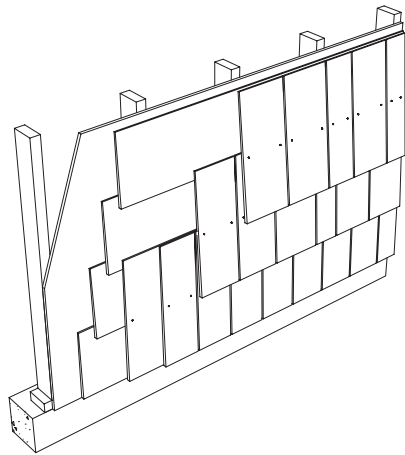

BEVELED SIDING DETAIL

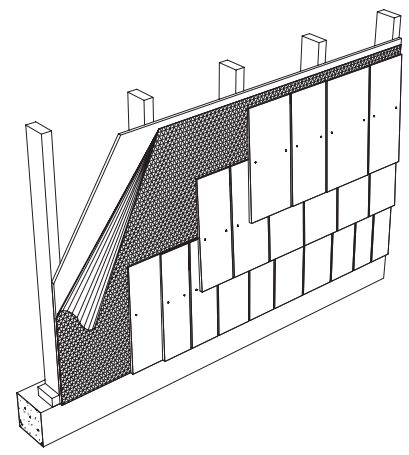

CEDAR BREATHER

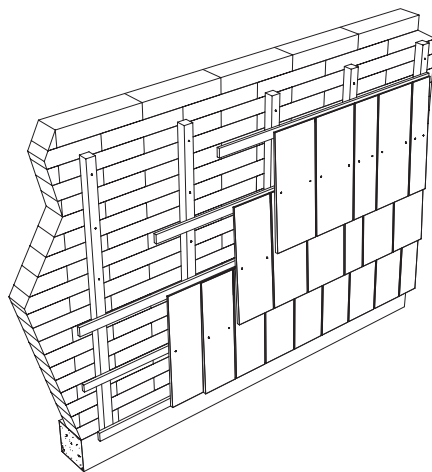

MASONRY DETAIL

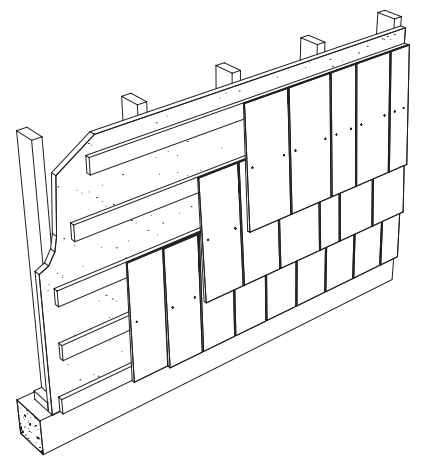

STUCCO DETAIL

FIGURE 1, 2

FIGURE 3, 4

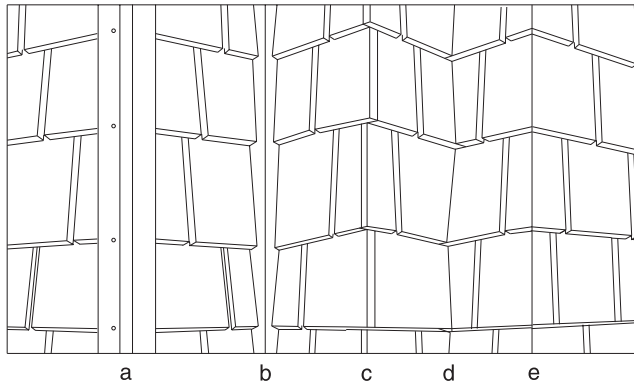

- a. Shingles butted against corner boards
- b. Shingles butted against square wood strip on inside corner, flashing behind
- c. Laced outside corner
- d. Laced inside corner with flashing behind
- e. Mitered corner

FIGURE 5

### CORNER DETAILS

### FURTHER READING

*Cedar Shake and Shingle Bureau Design and Application Manual for Exterior and Interior Walls*, Cedar Shake and Shingle Bureau, 1991.

*Cedar Shake and Shingle Bureau Membership Directory and Buyers Guide*, Cedar Shake and Shingle Bureau, Jan. 1998.

*A Guide to Southern Pine Shakes*, Southern Forest Products Association, Kenner, L.A., 1994.

*The Sovebec Guide to Installing Eastern White Cedar Shingles*, Charney, Canada: Sovebec, Inc.

### PRODUCT INFORMATION

Cedar Breather™, Benjamin Opdyke, Inc., 65 Steamboat Drive, John Fitch Industrial Park, Warminster, PA 18974-4889; 800-346-7655.

Cedar Shake & Shingle Bureau, P.O. Box 1178, Sumas, WA 98295; 604-462-8961; [www.cedarbureau.org](http://www.cedarbureau.org).

Sovebec Eastern White Cedar, Sovebec, Inc., 9201 Centre Hospitalier Blvd., Charney, Quebec, Canada G6x 1L5; 418-832-1456.

# SOLID WOOD SIDING

## ESSENTIAL KNOWLEDGE

Solid wood siding (particularly beveled siding such as clapboard) has been popular in the U.S. for the past 300 years. The use of wood siding has increased somewhat recently, according to the Western Red Cedar Lumber Association. However, its use is expected to decline as lumber becomes more costly, as quality materials become harder to obtain, and as other similar looking and less expensive materials become more popular (such as vinyl and fiber-cement siding).

The large majority of solid wood siding comes from the Western United States and Canada and is made of Western red cedar. A small portion is also made from Western redwood, and is available from individual mills. Solid wood siding from other softwoods such as vertical grain Western Douglas Fir is occasionally available, but in decreasing amounts. Some Eastern mills produce siding from softwoods such as white pine and spruce. Wood siding is usually treated with a protective coating such as a semi-transparent or opaque stain or paint. Individual industry associations have their own finishing recommendations (see Further Reading).

Most bevel siding (the most popular form of solid wood siding) is made from resawn lumber (1 inch thick boards that are sawn from logs and then cut diagonally on a band saw. Depending on where the 1 inch boards are cut, resawn lumber can be vertical grain, curved grain, or flat grain. Quartersawn (also known as “radial sawn”) siding is made from cuts radiating out from the center of a log, with the result that each piece is vertical grain (Fig. 1). Vertical grain siding is better at resisting warping and twisting. Curved and flat grain siding tends to twist opposite to the curve of the growth ring. Vertical grain siding also takes and holds paint better than flat grain because the maximum number of grain surfaces is exposed and acts as capillaries absorbing paint or stain for better adhesion. Since vertical grain is more stable than flat grain, the paint is also less stressed by twisting.

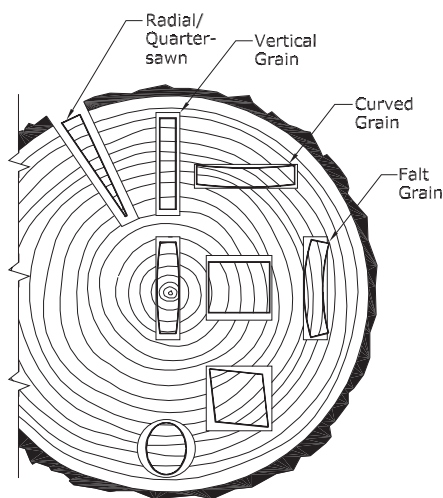

FIGURE 1

GRAIN CONFIGURATION AND SHRINKAGE CHARACTERISTICS

## TECHNIQUES, MATERIALS, TOOLS

### 1. REPAIR/REPLACE DAMAGED PIECES OF EXISTING BEVEL WOOD SIDING.

Individual pieces of bevel wood siding can easily be removed and replaced by cutting the nails holding the damaged sections with a hacksaw blade, and then by wedging and sawing the damaged sections out. New material can then be installed to butt existing material and fastened into place.

**ADVANTAGES:** Most economical repair.

**DISADVANTAGES:** Will not work with large areas of deteriorated material, which will have to be stripped down to the sheathing or structure.

### 2. REPLACE DETERIORATED OR DAMAGED SIDING WITH NEW WESTERN RED CEDAR BEVEL SIDING.

Resawn Western red cedar bevel siding has either two textured sides, or one textured and one smooth sanded side, depending on grade. Clear bevel siding results in the highest quality appearance with no visible knots. Bevel siding is available in plain bevel and rabbeted bevel (Fig. 2). Plain bevel is the most popular. Rabbeted bevel lays flatter on the wall and is somewhat easier to nail, but it has a less pronounced shadow line. Bevel siding ranges in exposure from 4 to 12 inches; with a butt thickness ranging from  $\frac{1}{2}$  to  $\frac{7}{8}$  inch. Red cedar bevel siding is available in six traditional grades: Clear V.G. Heart (smooth face, all vertical grain); A Clear (mixed grain); Rustic (some knots, sawn texture); B Clear (more knots and other growth characteristics); Select Knotty (significant sound and tight knots); Quality Knotty (considerable knots); and Architect Knotty Bevel Siding (comes with a variety of knots and other growth characteristics and is factory primed). Bevel siding is also available finger-jointed in lengths up to 16 feet in clear and knotty grades and in smooth, resawn, and combed (multiple grooved) textures.

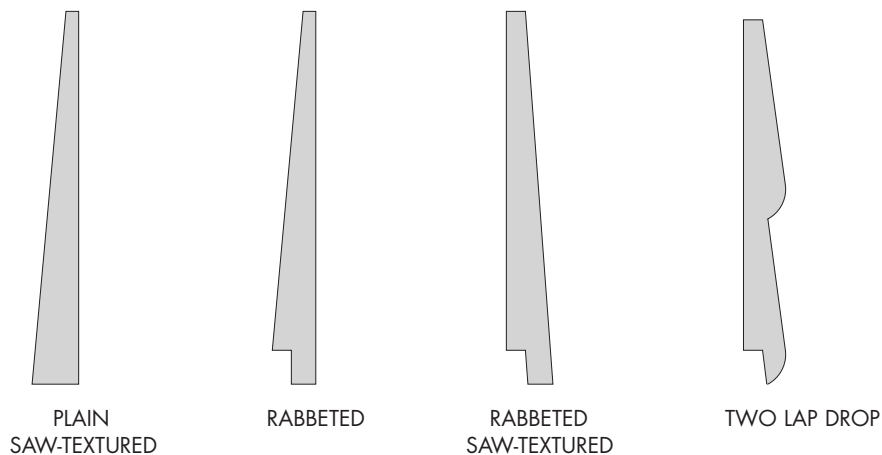

FIGURE 2

### BEVEL SIDING

A number of mills have arrangements with paint/stain companies, including Olympic, Cabot, and Sherwin Williams, which will provide 5-year warranties for factory-applied primer coat, increased to 15 years after the field application of an approved topcoat. If the siding is recoated before the 15-year warranty is over, it can be extended another 15 years for up to 30 years. Although some lower grades are used in conjunction with some extended warranty painting programs, vertical grain cedar will perform the best over an extended period (see Product Information).

Bevel siding can be applied directly, over building paper or house wrap to solid siding or sheathing, or to insulating sheathing if special application requirements for the insulating sheathing are adhered to (see Further Reading). It can also be applied to furring over masonry (on uneven walls or to allow for

the ventilation of the inside face of the cedar). Face nailing of bevel siding is recommended as blind nailing will split the thin, feathered portion of the shingle (Fig. 3). Stainless steel nails are recommended, especially in areas near the ocean. Hot-dipped galvanized or aluminum nails are acceptable in less corrosive environments. A variety of inside and outside corner details is possible (Fig. 4). Mitered corners are usually caulked and can separate if the wood is not properly seasoned and knots have been allowed to get wet prior to application. Corner boards are a good alternative. Non-hardening caulks are recommended, including polyurethane, polysulfide, or latex-silicone. For more information on installation refer to *Installing Cedar Siding* (see Further Reading).

**ADVANTAGES:** Western red cedar bevel siding has natural decay resistance, dimensional stability, workability, and paintability. Up to 30-year warranties available from paint companies make painted bevel siding competitive with other siding products. Available in vertical grain and in a variety of sizes, lengths (up to 16 feet), and finishes.

**DISADVANTAGES:** Will deteriorate and discolor over time if not maintained properly. Expands and contracts with changes in humidity and will shrink over time, causing vertical joints (which should be beveled) to open. May cup and twist, especially if flat grain is used instead of vertical grain. Combustible material; more costly than other siding products.

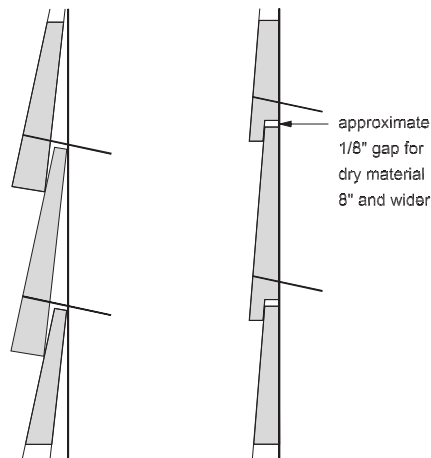

FIGURE 3

### FACE NAILING OF BEVEL SIDING

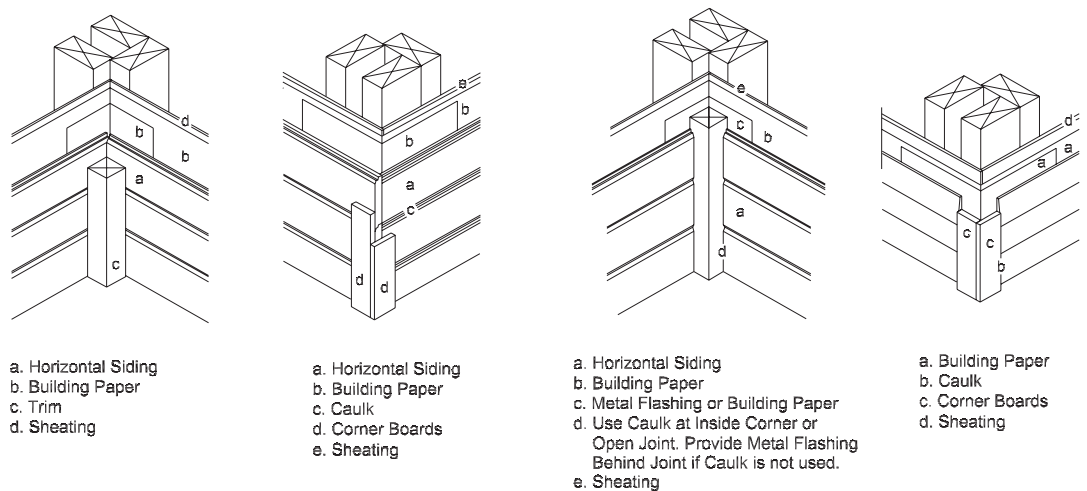

FIGURE 4

### 3. REPLACE DETERIORATED OR DAMAGED SIDING WITH NEW WESTERN REDWOOD BEVEL SIDING.

Redwood bevel siding has all of the favorable attributes of cedar bevel siding, but it is less available nationally and usually more costly than cedar. It comes in a variety of grades including Clear All Heart (all heartwood and free of knots); Clear (some sapwood and some small, tight knots); B Heart (a limited number of tight knots and other characteristics); B Grade (similar to B Heart except that it permits sapwood as well as heartwood). All these grades are available “certified kiln dried,” recommended for top performance and minimal shrinkage. Clear or Clear All Heart may be ordered either flat grain or vertical grain (recommended for best performance). Rustic grades are also available. Redwood bevel siding comes plain and rabbeted, smooth and rough sawn, and in a full range of sizes from 1/2 by 3 1/2 inches to 3/4 by 10 inches. Thinner widths are less likely to shrink and split than the wider widths. Redwood takes paint well, but individual mills haven’t been as aggressive as the cedar mills in developing warranty programs with the leading paint companies. Redwood bevel siding is applied and finished in the same manner as cedar. **ADVANTAGES:** Natural decay resistance, dimensional stability, paintability, and workability. Available in a variety of finishes, grains, sizes, and styles.

**DISADVANTAGES:** Will deteriorate and discolor over time if not maintained properly. Expands and contracts with changes in humidity and will shrink over time, causing vertical joints (which should be beveled) to open. May cup and twist, especially if flat grain is used instead of vertical grain. Combustible material; more costly than other siding products.

### 4. REPLACE DETERIORATED OR DAMAGED SIDING WITH NEW QUARTERSAWN SPRUCE OR PINE BEVEL SIDING.

Quartersawn Eastern spruce or pine bevel siding is available from the Granville Mfg. Co. The bevel siding comes in 1x Clear (clear, unmarked, or exposed section of siding); 2x Clear (up to one knot or blemish per piece); Cottage (not more than three knots or blemishes, no loose knots). Available in sizes from 7/16

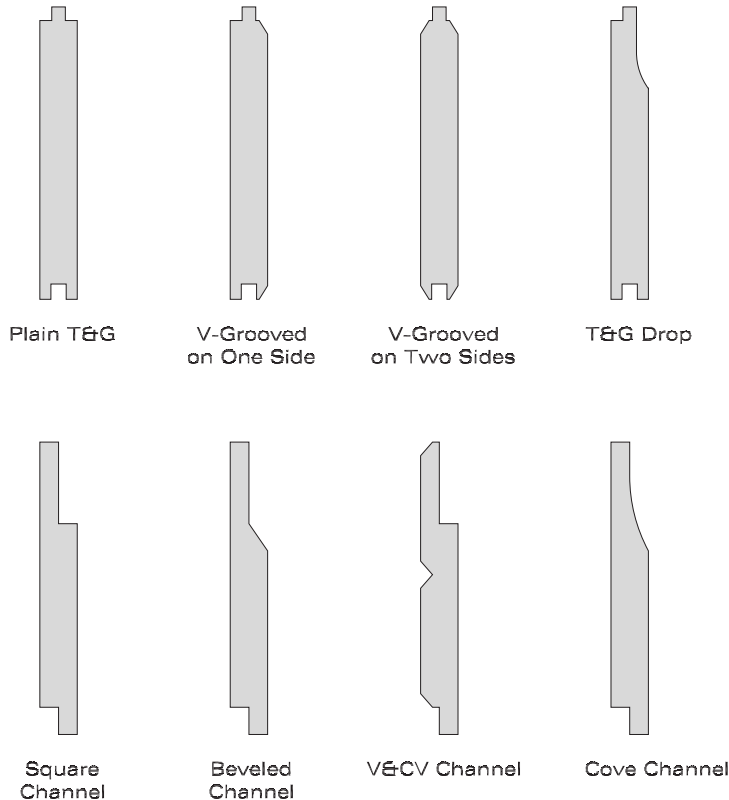

FIGURE. 5

NON-BEVEL WOOD SIDING

by 4 to 6 inches and up to 6 feet long. The material comes unpainted, primed, or painted.

**ADVANTAGES:** Vertical grain resists twisting and warping and accepts paint well. Authentic manufacturing meets all colonial reproduction specifications. Less costly than Western red cedar or redwood; long lifespan.

**DISADVANTAGES:** Requires maintenance and repainting. Available only in relatively short lengths (which shrink less). Will not match resawn siding. Available only in 2½ to 4-inch exposures. Combustible material.

## **5. REPLACE DETERIORATED OR DAMAGED SIDING WITH NON-BEVEL SOLID WOOD SIDING.**

Non-bevel wood siding types include board and batten, drop siding, shiplap, tongue-and-groove, and variations of these types (Fig. 5). Many, including tongue-and-groove and shiplap, can be installed horizontally in the same manner as bevel siding, and vertically with blocking between studs, or over horizontal furring strips. The grades of the siding products are similar to those for bevel siding. For detailed sizes and specifications (see Further Reading and Product Information).

**ADVANTAGES:** A wide variety of distinctive, historically correct products for both traditional and contemporary use. Available from individual suppliers with vertical grain and extended painting warranties.

**DISADVANTAGES:** Requires periodic maintenance; more costly than other siding products; combustible.

## **FURTHER READING**

*Certified Kiln Dried Siding Applications*, Novato, CA: California Redwood Association, 1995; 888-225-7339; [www.calredwood.org](http://www.calredwood.org).

*Designer's Handbook*, Vancouver, BC: Western Red Cedar Lumber Association, Nov. 1997; 604-684-0266; [www.wrcla.org](http://www.wrcla.org).

*Guidelines for Installing and Finishing Wood and Hardboard Siding Over Foam Sheathing*, American Forest and Paper Association; 202-463-2700; [www.afandpa.org](http://www.afandpa.org).

*Installing Cedar Siding*, Western Red Cedar Lumber Association; 604-684-0266; [www.wrcla.org](http://www.wrcla.org).

*Natural Wood Siding—Technical Guide*, Portland, OR: Western Wood Products Association, May 1998; 503-224-3930; [www.wvpa.org](http://www.wvpa.org).

*Redwood Architectural Guide*, Novato, CA: California Redwood Association, 1998; 888-225-7339; [www.calredwood.org](http://www.calredwood.org).

*Redwood Lumber Grades and Uses*, Novato, CA: California Redwood Association, Dec. 1995; 888-225-7339; [www.calredwood.org](http://www.calredwood.org).

*Specifying Cedar Siding*, Vancouver, BC: Western Red Cedar Lumber Association, May 1998; 604-684-0266; [www.wrcla.org](http://www.wrcla.org).

*Using Redwood Siding Over Rigid Foam Insulation*, Novato, CA: California Redwood Association, Sept. 1994; 888-225-7339; [www.calredwood.org](http://www.calredwood.org).

## **PRODUCT INFORMATION**

Granville Manufacturing Co., Granville, VT 05747; 802-767-4747; quartersawn spruce and pine clapboard siding.

Siding 2000, pre-finished cedar siding: Coastal Forest Products, 451 South River Road, P.O. Box 10898, Bedford, NH 03110; 800-932-WOOD.

Skookum Lumber Co., Box 1398, Olympia, WA 98507-1398; 360-352-7633 (cedar siding).

Step Saver Siding: Factory Primed Western Red Cedar; PPG Industries, Inc., 1 PPG Place, Pittsburgh, PA 15272; 800-441-9695; [www.ppgaf.com](http://www.ppgaf.com).



# HARDBOARD SIDING

## ESSENTIAL KNOWLEDGE

Hardboard siding was first developed by William Mason in 1922. The product is made of wood chips converted into fibers, combined with natural and synthetic binders, bonded under heat and pressure. The early success of this material led to a proliferation of hardboard manufacturers in the early 1950s when the original patents expired. More than a score of companies were producing hardboard siding by the 1970s when the EPA's newly declared environmental restrictions on the dumping of waste water from hardboard's wet manufacturing process led to the closing of a number of plants that did not have the space or resources to make required changes. By the mid-1980s hardboard siding accounted for about 30 percent of the United States residential siding market. Today, hardboard siding's market share has declined to approximately 15 percent. The number of current manufacturers has been reduced to six. The constricted market is due to the growth in use of other materials such as vinyl siding, exterior insulation and finish systems (EIFS), and fiber-cement siding.

There has been considerable publicity about class action lawsuits against certain manufacturers regarding the material's performance when exposed to moisture. Manufacturers have countered that, while lapses in quality control may have occurred, hardboard has a long history of good performance and that the majority of problems is due to inadequate field supervision (particularly regarding incorrect flashing, caulking, nailings, and painting) by installers around windows, doors, deck terminations, and other potential moisture entry points, and the lack of sufficient maintenance on the part of homeowners.

The majority of the class action lawsuits has been settled, and the major manufacturers continue to produce and sell hardboard siding with limited 25- to 30-year warranties. Some products are undergoing continued design improvements, others have changed relatively little over the years. Masonite Corp., for example, has developed a new lap siding product called HiddenRIDGE™ with concealed fasteners and interlocking design that speeds installation and provides level alignment (Fig. 2).

## TECHNIQUES, MATERIALS, TOOLS

### 1. REPAIR EXISTING HARDBOARD LAP SIDING.

Small sections of damaged or deteriorated lap siding can be cut out and replaced with matching profiles relatively easily with conventional carpentry tools, including handsaws and power saws. Deteriorated sheathing should be replaced as required. Panel siding sections can be repaired as well, but with greater difficulty.

ADVANTAGES: Most economical repair.

DISADVANTAGES: Large areas of damaged material have to be stripped down to sheathing or structure. Repaired sections may not exactly match existing siding.

### 2. REPLACE EXISTING SIDING WITH NEW HARDBOARD LAP SIDING.

Lap siding is available in  $\frac{7}{16}$  and  $\frac{1}{2}$  inch thicknesses and in a wide variety of configurations including shiplap siding 12 and 16 inches wide in lengths up to 16 feet with varying profiles, as well as conventional 6, 8, or 12 inches wide lap siding made to look like beveled siding (Fig. 2). Most products are pre-primed and require two coats (4 dry mils) of field painting. Masonite offers a completely pre-finished, "Colorlock" siding that comes with a 15-year limited warranty on the finish. Lap siding can be applied over

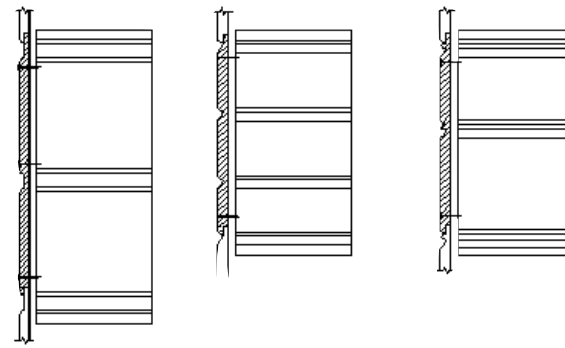

SHIPLAP SIDING

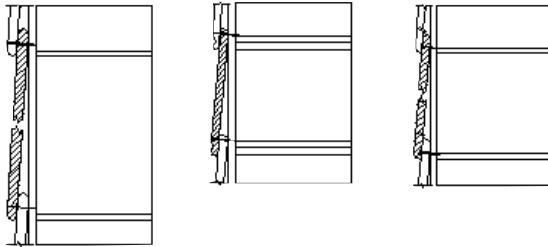

LAP SIDING

COLORLOK SIDING

FIGURE 1

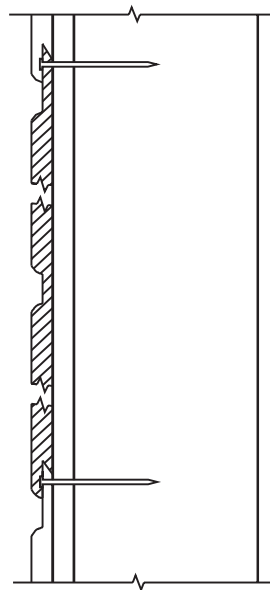

SHIPLAP SIDING  
HIDDEN RIDGE

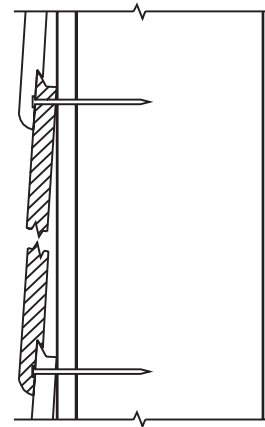

LAP SIDING

FIGURE 2

existing sound and level siding, over solid or insulating sheathing, directly over studs 16 inches o.c. with an approved water-resistant barrier, or over furring strips. Staples, t-nails, or bugle head nails are not recommended. Hardboard, as all materials, will expand and contract with temperature and humidity variations. A minimum  $\frac{3}{16}$  inch space is recommended between the siding and windows, door frames, and corner boards and  $\frac{1}{16}$  inch between vertical butt joints, which must fall on studs. All joints must be caulked with non-hardening, mildew-resistant exterior grade sealant.

**ADVANTAGES:** Hardboard lap siding has been used successfully for over 50 years and remains the preferred siding material in some markets. Available in a wide variety of profiles, textures, and styles that accurately simulate the appearance of wood products. Easily worked and handled. A consistent product with no surface defects. Available in lengths up to 16'. Less costly than solid wood siding products.

**DISADVANTAGES:** More susceptible to moisture-related problems than other siding materials. Requires careful storage and protection during construction. Should not be applied over wet sheathing. Requires careful attention to fastening, caulking, and painting recommendations. Long lengths of siding may buckle due to expansion. Requires periodic inspection and maintenance of caulking and painting.

### **3. REPLACE EXISTING SIDING WITH NEW HARDBOARD PANEL SIDING.**

Of the hardboard siding sold, panel siding represents about a third. It is available in 4x8 and 4x9 square-edge panels (for board and batten applications) and shiplap-edge panels. The panels come in a variety of textures and groove configurations that simulate vertically applied wood boards. The material is also available without grooves in a stucco appearance. Temple-Inland offers a 16 by 48-inch panel called "Shadowround" that simulates scalloped shingles. Hardboard panels may be applied to sheathed or unsheathed walls with studs no more than 24" o.c., or over sound flat existing siding. Panel edges must fall on and be nailed to framing members. Horizontal joints must have adequate blocking and be overlapped a minimum of 1" or be provided with Z-shaped preformed flashing. The material is available pre-primed for field painting.

**ADVANTAGES:** A consistent material without knots, raised grain, checks, or other surface defects. Takes paint well and has been used successfully for many years when properly installed and maintained. Can provide shear resistance when installed directly over studs. Available in a variety of attractive patterns and finishes. Easily worked and handled.

**DISADVANTAGES:** Requires careful storage and protection during construction. Requires careful attention to fastening, caulking, and painting requirements. Requires periodic inspection and maintenance of caulking and painting.

## **FURTHER READING**

*ANSI/AHA 135.6-1990 Hardboard Siding*, Palatine, IL: American Hardboard Association, 1998.

*Maintenance Tips for Hardboard Siding*, Palatine, IL: American Hardboard Association, 1997.

*Recommended Basic Application Instructions for Hardboard Siding*, Palatine, IL: American Hardboard Association, 1994.

*Today's Hardboard*, Palatine, IL: American Hardboard Association, February 1998.

## **PRODUCT INFORMATION**

American Hardboard Association, 1210 West Northwest Highway, Palatine, IL 60067; 847-934-8800.

Hardboard Manufacturers:

ABT Building Products Corp., 3250 West Big Beaver Road, Troy, MI 48084; 810-649-3300.

Collins Products, LLC, P.O. Box 16, Klamath Falls, OR 97601; 541-883-4853.

Forestex Co., P.O. Box 68, Forest Grove, OR 97116; 503-357-2131; [www.stimsonlumber.com](http://www.stimsonlumber.com).

Georgia Pacific Corp., 133 Peachtree St., NE, Atlanta, GA, 30303; 800-284-5347; [www.gp.com](http://www.gp.com).

Masonite Corp., 1 South Wacker Drive, Chicago, IL 60606; 312-750-0900.

Temple-Inland Forest Products Corp., P.O. Drawer N, Diboll, TX 75941; 409-829-5511.

# ENGINEERED WOOD SIDING

## ESSENTIAL KNOWLEDGE

Louisiana-Pacific (the largest producer of oriented strand board (OSB)) introduced Inner-Seal™ OSB siding in the mid-1980s as an economical alternative to conventional wood siding products that had become more costly due to rising lumber prices. While the material proved popular with builders, some performance problems arose, particularly in humid environments such as the Northwest and Southeast. Where nail holes, material surfaces, and edges were not adequately painted or sealed, water penetrated, causing the OSB siding to swell and expand. Some OSB siding deteriorated due to rot, fungus, and invasion by insects, in some cases causing damage to sheathing beneath. A number of class action lawsuits were brought against the manufacturer, and L-P has settled these claims.

Since then, L-P has re-engineered the material and has reintroduced it as a “treated engineered wood product” instead of an OSB product, offering bevel-edged siding in 16-foot lengths with 6, 8, 9 1/2, and 12 inch widths; and 4 by 8 to 4 by 16 panels. The composition and production process have been substantially revised. The binder has been changed from a phenolic to methylene diphenyl diisocyanate (MDI), which is more water resistant and provides a stronger bond to the wood flakes, therefore reducing the swelling and expansion. Powdered zinc borate has been included to prevent rot, fungal growth, and insect-caused deterioration. A prefinished resin-saturated paper embossed with a pronounced wood grain is thermal-fused to the wood substrate, and a proprietary sealant treatment is applied to ends and edges. The siding is prefinished with an all-acrylic primer. Fascia and trim products are also available.

## TECHNIQUES, MATERIALS, TOOLS

### 1. REPLACE DAMAGED OR DETERIORATED SIDING WITH NEW L-P SMART LAP™ SIDING.

Depending on the most cost-effective approach, engineered wood lap siding can be installed directly to studs with a weather barrier (Fig. 1); directly to nailable sheathing; over “fan-fold” insulating sheathing; or to furring strips over masonry or irregular surfaces (siding should not come in contact with masonry). If a rainscreen/drainage channel behind the siding is desired the siding can be installed over vertical furring strips at a maximum spacing of 24 inches o.c. Sections of existing Inner-Seal™ OSB siding that have swelled, edge cracked, or otherwise deteriorated, can be cut out and replaced with new sections of L-P engineered wood siding, which will closely match the appearance of the old OSB siding. For complete instructions refer to *Application Instructions for Smart Panel™ and Smart Lap™ Siding*.

**ADVANTAGES:** Lightweight, strong, easily worked with conventional tools; appearance of textured painted cedar siding; joints at trim similar to wood bevel siding; lays flat. Dimensionally stable; will not warp or cup; free from knot holes; resistant to end-checking and splitting, shrinkage, and buckling. Twenty-five-year prorated limited warranty against fungal degradation, and cracking, peeling, separating, chipping, flaking, or rupturing of the resin-impregnated surface overlay. Environmentally sound; made from a renewable resource.

**DISADVANTAGES:** Requires repainting and recaulking over time. New product with limited performance history. Combustible material. Currently not available in smooth patterns.

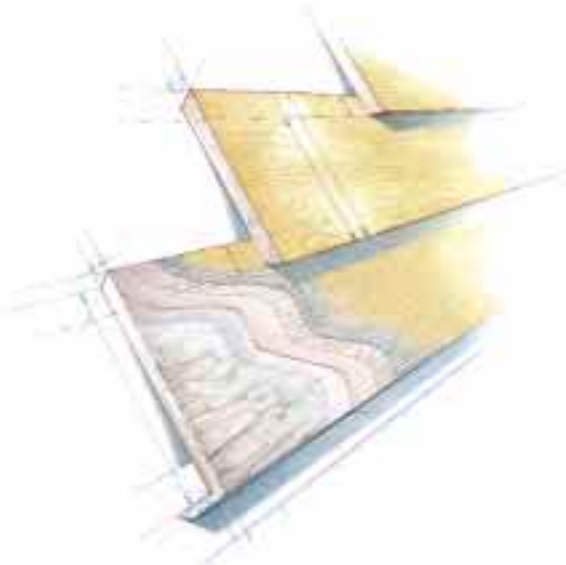

SMART LAP

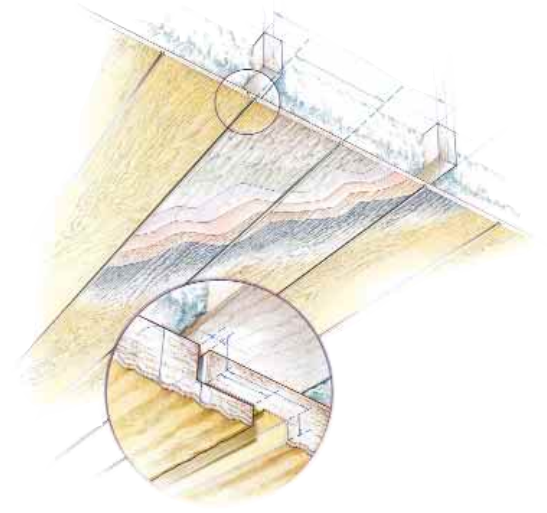

SMART PANEL

FIGURE 1, 2

**2. REPLACE DAMAGED OR DETERIORATED SIDING WITH NEW L-P SMART PANEL™ AND EZ PANEL™ ENGINEERED WOOD PANELS.**

Available in a variety of thicknesses and patterns simulating vertically grooved plywood siding (Fig. 2). Panels have shiplapped edges and may be used directly over studs, over structural or nonstructural sheathing, over existing sound wood siding, and on furring strips over masonry and uneven walls. Panels should not contact masonry surfaces and vertically grooved panels should not be applied horizontally. Nails must be stain and corrosion resistant and have a minimum 1/4 inch head. Nails driven below the surface must be sealed. All joints must be caulked with non-hardening paintable sealant with a service life of at least 25 years. Horizontal trim should not be placed over grooved siding without proper flashing. If flashing is not practicable, space trim away from siding so that moisture is not trapped between siding and trim. For detailed installation and painting requirements refer to *Application Instructions for Smart Panel™ & EZ Panel™ Siding*.

**ADVANTAGES:** Less costly than plywood. Smart Panel™ can act as a shear wall; does not require sheathing. Comes primed and can be painted any color. Natural looking wood grain texture. Easily handled and installed with conventional tools. Twenty-five-year prorated limited warranty against fungal degradation, cracking, peeling, separating, chipping, flaking, or rupturing of the resin-impregnated surface overlay. Comparable five-year warranty on EZ Panel™, which is a utility grade.

**DISADVANTAGES:** Engineered panels require regular repainting and recaulking. New product with limited performance history. Combustible material.

**FURTHER READING**

*Application Instructions for Smart Panel™ & Smart Lap™ Siding*, Louisiana-Pacific, March 1998.

**PRODUCT INFORMATION**

Louisiana-Pacific, 111 SW Fifth Avenue, Portland, OR 97204; 800-648-6893; www.LPcorp.com (Smart Lap™, Smart Panel™, and EZ Panel™ siding).

# PLYWOOD PANEL SIDING

## ESSENTIAL KNOWLEDGE

Plywood panel siding has been a popular material, especially in the Northwest, North Central, and Northeastern states, since the early 1950s. Its use has declined in the last decade, however. Further market erosion is expected in the next decade as other siding products, such as vinyl siding and fiber cement, continue to increase in popularity.

As a material, plywood panel siding has changed very little in terms of specifications or product configuration, except that a variety of special veneer facings is now available that increases paintability and extends the life of the siding. Some of these products include Simpson Forest Products' Guardian™ siding made with a medium density overlaid resin-impregnated craft paper; Roseburg Forest Products' Breckenridge Siding™ made with "okoume" hardwood surface overlay imported from New Zealand; and Stimson Lumber Company's Duratemp™ made with a hardboard surface overlay. As an alternative to special surface overlays, many manufacturers offer preprimed plywood siding, although the great majority of siding is still sold as unprimed.

## TECHNIQUES, MATERIALS, TOOLS

### 1. REPAIR EXISTING PLYWOOD SIDING.

Sections of damaged or deteriorated plywood panels can be cut out and repaired with conventional carpentry tools if there is sheathing below, but the most typical repair would be to replace the individual panel. **ADVANTAGES:** Most economical repair.

**DISADVANTAGES:** Repair of individual panels is often not practical, especially if panel is fastened directly to structure.

### 2. REPLACE EXISTING SIDING WITH NEW PLYWOOD PANEL SIDING.

Made from Douglas fir or (increasingly) Southern pine veneers, plywood siding is available in 4 by 8, 4 by 9, and 4 by 10 panels in varying thicknesses, including  $\frac{11}{32}$ ,  $\frac{15}{32}$ , and  $\frac{19}{32}$  inches. Panels are available smooth faced or textured, grooved or ungrooved, square or shiplap edged. Siding patterns include channel-grooved, brushed, overlaid, Texture 1-11, reverse board-and-batten, rough sawn, and kerfed rough sawn (Fig. 1). Battens can be applied for a board-and-batten appearance. Depending on the depth of the grooves, the panels are designed to be attached directly to framing members 16 or 24 inches o.c., or over existing flat siding, insulating or solid sheathing, or furring strips against masonry or uneven walls. Plywood siding must be primed and finish painted or stained within 30 days of installation. Unless properly maintained, the surface ply will degrade due to UV and weathering effects and will become brittle, cracked, and eroded.

**ADVANTAGES:** Long history of successful applications. Can be applied directly to studs without sheathing. Can provide shear resistance. Easily worked and erected with conventional tools. One panel covers a large surface area. Dimensionally stable. Available in a variety of textures and styles. Products with special overlaps have surfaces that, after painting, will not split, check, or crack. Limited 25-year warranties are available.

**DISADVANTAGES:** Vertical grooves impart a distinctive, "contemporary" appearance that may not be suitable given the existing design of the house to be rehabed. Use is generally confined to Northern regions



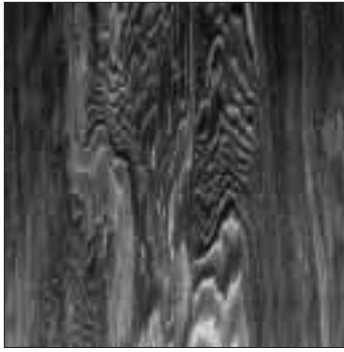

BRUSHED

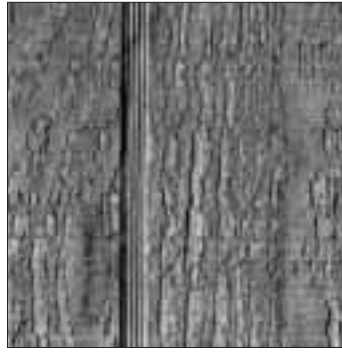

CHANNEL GROOVE

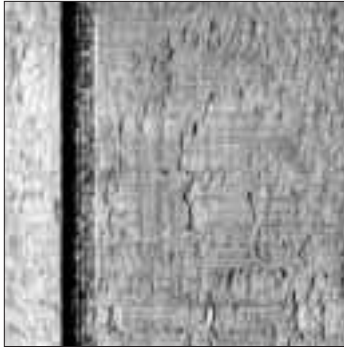

TEXTURE 1-11



LAP SIDING



SMOOTH OVERLAID T1-11

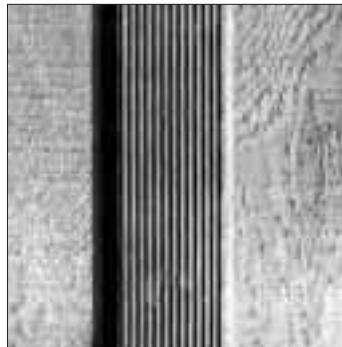

REVERSE BOARD-AND-BATTEN



KERFED



OVERLAID T1-11

PLYWOOD PANEL TEXTURES

FIGURE 1



of the U.S. Conventional plywood without overlays requires careful attention to initial painting/staining recommendations. Combustible. Requires on-going maintenance.

## **FURTHER READING**

*303 Siding Manufacturing Specifications*, APA Engineered Wood Association, March 1997.

*Performance Rated Siding*, APA Engineered Wood Association, April 1996.

*Residential Design and Construction Guide*, APA Engineered Wood Association, April 1996.

## **PRODUCT INFORMATION**

Breckenridge Siding™: Roseburg Forest Products, P.O. Box 1088, Roseburg, OR 97420; 800-859-6998.

Champion International Corporation, One Champion Plaza, Stamford, CT 06921; 800-874-3240.

Duratemp Plywood Siding™: Stimson Lumber Company, 520 Southwest Yamhill, Suite 325, Portland, OR 97204; 800-445-9758.

Georgia-Pacific Corporation, P.O. Box 105605, Atlanta, GA 30348-5605; 800-284-5347.

Guardian Siding™: Simpson Timber Company, Third and Frankline, Shelton, WA 98584; 800-782-9378.

Louisiana-Pacific, 111 Southwest Fifth Avenue, Portland, OR 97204; 800-231-1292.

U.S. Forest Industries, Inc., P.O. Box 820, Medford, OR 97501; 800-541-6906.

# FIBER-CEMENT SIDING

## ESSENTIAL KNOWLEDGE

Fiber-cement siding, in its present form, is a relative newcomer to the U.S. homebuilding market, having been introduced in the late 1980s. Asbestos-cement siding, an earlier incarnation of the material, had been used extensively in the U.S., as well as in Europe, throughout the 20th century. The use of asbestos in the U.S. was discontinued in the 1970s. Currently fiber-cement siding products are composed of Portland cement, sand, clay (in some products), and specially treated wood. Today's products are thicker, less brittle, and easier to cut and work with than asbestos materials. They are also available in a wider variety of products such as backer board, lap siding, panel siding, trim, soffits, and fascias.

Fiber-cement siding has generated a great deal of interest among builders and homeowners because of its strength and impact, rot, and fire resistance. Expectations are that the use of fiber-cement products and the development of new product types, such as fiber-cement shingle siding, will increase dramatically in the next several years.

Fiber-cement siding can be cut and drilled with conventional wood-working tools (although some installers use diamond-tipped masonry blades for cutting) or scored with special shearing tools and broken much like paper-faced drywall. Fiber-cement panels are available either preprimed or unpainted, depending on the individual manufacturer. Paint adheres very well to the material's slightly textured and porous surface. The material itself is not affected by intermittent wetting, but it will discolor and stain unless painted.

## TECHNIQUES, MATERIALS, TOOLS

### 1. REPAIR EXISTING FIBER-CEMENT SIDING.

Dented, cracked, or otherwise distressed siding can be repaired with the use of a latex-modified cementitious patching compound available from fiber-cement manufacturers or from specialty product manufacturers (see Product Information). Damaged sections can be cut out with hand or power saws and new sections installed as necessary. Joints between new and old materials should be primed and caulked.

**ADVANTAGES:** Can be repaired in much the same manner as solid wood siding.

**DISADVANTAGES:** Some of the wood grain and stucco patterns have changed somewhat. Adjoining new and old sections may not match exactly.

### 2. REPLACE EXISTING SIDING WITH FIBER-CEMENT LAP SIDING.

Fiber-cement lap siding is typically available in a variety of textures, widths from 6 to 12 inches, lengths up to 12 feet, and in thicknesses between  $\frac{5}{16}$  and  $\frac{7}{16}$  inches (Fig. 1). It can be installed directly to studs with a suitable weather barrier such as housewrap or building paper, or over solid or insulating sheathing, existing solid wood siding, or furring strips applied to uneven walls or existing masonry surfaces. Fiber-cement lap siding can be used with conventional wood, fiber-cement, hardboard, or vinyl trim. Lap siding is fastened by means of stainless or galvanized steel nails, or by means of screws with corrosion-resistant coatings. Staples are not recommended. Refer to individual manufacturer's installation manuals for specific recommendations.

**ADVANTAGES:** Smooth lap siding is close to wood in appearance when painted. Performs well in high-humidity environments; will not rot; termite resistant; non-combustible; good impact resistance; can be



SMOOTH FINISH



TEXTURED



SMOOTH BEADED LAP



TEXTURED BEADED LAP



COLONIAL SMOOTH



COLONIAL ROUGHSAWN

### LAP SIDING TEXTURES

FIGURE 1

painted or stained. Up to 50-year limited product warranty against manufacturing defects.

**DISADVANTAGES:** Wood grain is somewhat more pronounced than rough-sawn cedar. Surface texture can be distracting in appearance at joints where grain does not align. Requires periodic painting and caulking, although requires less frequent painting than wood. Variety of siding patterns is less than with other



SMOOTH FINISH

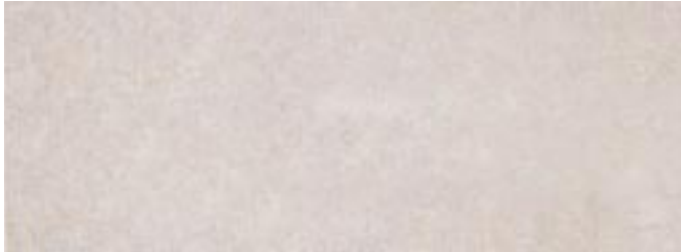

STUCCO FINISH



CEDAR TEXTURE WITH  $\frac{5}{8}$ - INCH GROOVES, 8-INCH ON-CENTER



CEDAR TEXTURE WITH MOLDED GROOVES AT 4-INCH INTERVALS

FIGURE 2

### PANEL SIDING TEXTURES

siding materials. Heavier than wood. Cutting of material with saws produces silica dust. Brittleness of material results in significant wear on tools.

#### **3. REPLACE EXISTING SIDING WITH FIBER-CEMENT PANEL SIDING.**

Fiber-cement panels are typically 4 by 8, 4 by 9, and 4 by 10, and typically in  $\frac{5}{16}$ -inch thickness. A variety of textures is available, depending on the manufacturer (Fig. 2). Installed vertically to studs directly, the panels can act as shear wall bracing. They can also be installed over solid sheathing, existing flush solid wood siding, or over furring strips against masonry or uneven walls. If required by code, a weather barrier must be installed. Corrosion-resistant nails or screws may be used. Staples are not recommended. Joints should fall on structural framing members and are typically caulked or covered with a batten strip. Horizontal joints are flashed with metal Z flashing.

Horizontal joints are flashed with metal Z flashing.

**ADVANTAGES:** Installs quickly, covering a large area; performs well in high-humidity environments. Can provide shear bracing. Termite resistant, noncombustible, good impact resistance. Can be painted or stained; up to 50-year limited product warranty against manufacturing defects.

**DISADVANTAGES:** Textures do not accurately reflect materials they simulate. Heavier and more brittle than most siding materials. Material requires special tools to cut and install; requires periodic painting and caulking. Cutting of material with saws produces silica dust. Variety of panel patterns and textures is less than other types of panel materials.

## **FURTHER READING**

“On Site with Fiber-Cement Siding,” David Frane, *Journal of Light Construction*, January 1998.

## **PRODUCT INFORMATION**

### **FIBER-CEMENT MANUFACTURERS**

ABTco., 10115 Kinsey Ave., Suite 150, Huntersville, NC 28075; 800-566-2282; www.abtco.com (lap and panel siding).

FCP™, Inc. (successor sales arm of Eternit, Inc.), Excelsior Industrial Park, P.O. Box 99, Blandon, PA 19510-0099; 888-327-0723 (Cemplank™ smooth, rough-sawn, and wood grain lap siding; Cempanel™ smooth, stucco, and wood grain vertical siding panel).

James Hardie Building Products, Inc., 26300 La Alameda, Suite 250, Mission Viejo, CA 92691; 800-9-HARDIE; www.jameshardie.com (Hardiplank™ smooth, rough sawn, and wood grain lap siding; Hardipanel™ smooth, stucco, wood grain vertical siding panels; Shingleside™ fiber-cement shingle; Hardisoffit™, Harditrim™).

Maxitile, Inc., 17141 S. Kingview Ave., Larson, CA 90746; 800-338-8453 (MaxiPlank™ smooth and wood grain lap siding; MaxiPanel™ smooth, wood grain, V-groove, stucco panels; MaxiTrim™).

Temple-Inland Forest Products Corp., Inc., P.O. Drawer N, 303 Temple Dr., Diboll, TX 75941; 800-231-6060.

### **CUTTING TOOLS**

Pacific International Tool & Shear, P.O. Box 1604, Kingston, WA 98346; 800-297-7487.

### **PATCHING PRODUCTS**

Macklanberg Duncan™, 4041 North Santa Fe, Oklahoma City, OK 73118; 800-654-8454.

### **VINYL TRIM AND VENT ACCESSORIES**

Tamlyn and Sons, 10406 Cash Road, Houston, TX 77477; 800-334-1676.

## EXTERIOR INSULATION AND FINISH SYSTEMS

## ESSENTIAL KNOWLEDGE

Developed in Europe in the 1950s, and introduced into the U.S. by Dryvit Systems, Inc. in the early 1970s, exterior insulation and finish systems (EIFS), which are sometimes called synthetic stucco systems, have largely replaced conventional three-coat Portland cements stucco systems. The industry's association, the EIFS Industry Members Association (EIMA) estimates that EIFS currently account for about 3.5 percent of the residential wall market in the U.S.

The system's attributes include the benefits of insulation outside the structure (a significant thermal break advantage); reduced air infiltration due to the monolithic nature of the finished membrane; and great design flexibility. While many of the thousands of buildings clad with EIFS have had few, if any, problems, poor EIFS performance has been documented on individual projects on an ongoing basis, particularly in climates with severe temperature swings and high moisture levels. Most recently, attention has focused on large-scale repairs to houses in Wilmington, N.C., following the discovery that moisture had entered the EIFS barrier cladding systems through the juncture between EIFS and windows or doors, at deck terminations, at roof/wall connections, and at window sills. In the absence of drainageways, moisture trapped behind the EIFS cladding caused deterioration of the substrate. The adverse publicity and class-action lawsuits that followed have led to a curtailment in the use of barrier EIFS systems in some states, although not nationally.

Concern about the use of EIFS among the public, the insurance industry, building officials, and manufacturers has also led to the development and promotion of new EIFS products that incorporate drainageways and moisture barrier membranes behind the insulation boards that allow infiltrating water to drain out (Fig. 1). The EIFS industry remains fragmented (EIMA represents only 8 of the 30 to 40 EIFS manufacturers, although its members produce an estimated 85 to 90 percent of the systems sold) and EIFS installation systems and details vary among manufacturers. However, American Society for Testing Materials (ASTM) has developed recommended installation details and specifications that are part of a new ASTM standard (ASTM C1397) for barrier type systems. Water managed systems have yet to be addressed by ASTM. EIMA is working with the National Association of Home Builders (NAHB) Research Center to develop a third-party applicator certification program.

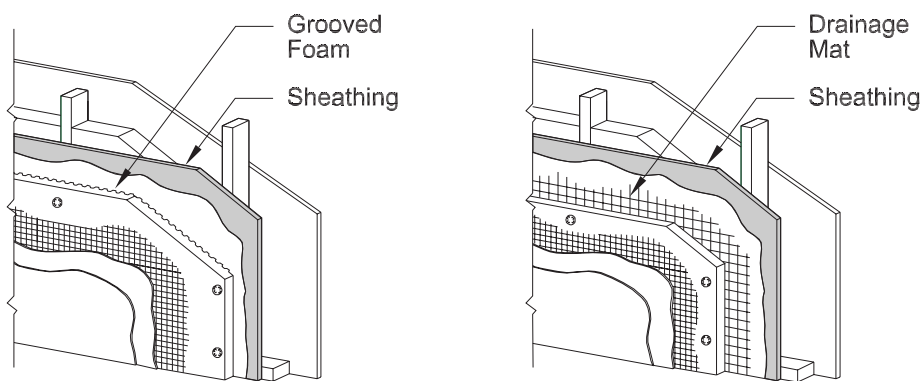

GROOVED INSULATION BOARD

DRAINAGE LATH/MAT

## TECHNIQUES, MATERIALS, TOOLS

There are two major classifications of EIFS: barrier systems (which depend on the integrity of the EIFS surface, flashing, and sealants to prevent entry of water), and drainage systems (which employ a variety of drainage techniques to allow moisture, that may have entered, to exit the system).

### 1. REPAIR EXISTING EIFS.

The repair of small damaged areas of EIFS, where the substrate is sound, is relatively simple. The affected area is cut out and the system is rebuilt in much the same way as it was originally installed. If the damage was caused by water infiltration from deficient flashing, the flashing should be repaired or replaced before corrective work begins. If the sealant has failed it should be removed and replaced or covered with caulking products designed for this remedial work. Dow Corning, among other manufacturers, has developed a variety of restoration recommendations and remedial products, including a preformed silicone extrusion (Dow Corning 123 silicone seal – Fig. 2) that is designed to span failed sealant joints and weatherseals at the perimeter of windows and other wall penetrations (see Further Reading). If the deterioration due to faulty installation or water entry is extensive, the EIFS may have to be removed in its entirety and, in some cases, the sheathing, trim, windows, and structure as well.

**ADVANTAGES:** Repairs are simple and work well on small damaged areas where significant water penetration and substrate deterioration has not occurred.

**DISADVANTAGES:** Serious water entry problems can require extensive removal and rebuilding work. Repaired areas will probably not match the color of adjacent existing areas and may require a new color coat.

### 2. INSTALL AN EIFS BARRIER SYSTEM.

Barrier systems have been the basic industry standard until recently, and EIMA and many manufacturers maintain that when properly detailed and installed they will perform satisfactorily. Some manufacturers, however, disagree. U.S. Gypsum offers only draining, water-managed systems and Senergy, Inc. will not authorize the installation of barrier systems on wood frame construction (all manufacturers agree that barrier systems work over masonry block or concrete substrates that are relatively unaffected by mois-

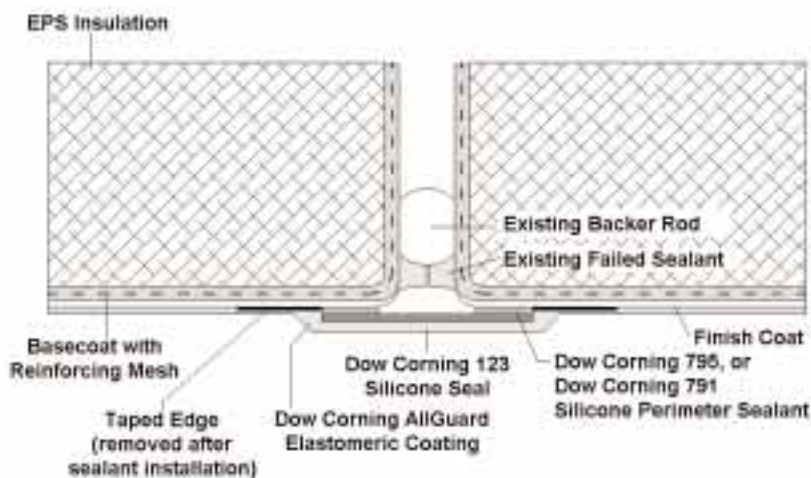

FIGURE 2

### SILICONE SEAL

ture). EIFS typically consist of insulation board made of polystyrene (usually expanded) or polyisocyanurate foam, which is secured to the exterior wall surface (usually DensGlass Gold<sup>®</sup>, plywood, OSB, or fiber-cement board) with a specially formulated adhesive or with mechanical fasteners. The foam provides insulation and allows the coating to flex during temperature swings. Some manufacturers provide EIFS without



the insulation for installation over masonry or directly to sheathing when insulation is not required (Fig. 3). A water-resistant base coat is applied to the top of the insulation and reinforced with glass-fiber mesh for added strength. A final coat, typically acrylic, similar to a thickened acrylic paint with a fine aggregate, is applied as the finish surface. Some manufacturers provide elastomeric coatings, which are softer and more flexible than the coatings typically used.

**ADVANTAGES:** More effective than (although often used in conjunction with) comparable between-the-studs insulation, especially over metal studs. Provides an important thermal break. Reduces air infiltration (EIMA claims up to a 55 percent reduction over standard masonry or wood construction). Provides attractive exteriors and design flexibility through a wide variety of colors and textures. Can be fashioned into a variety of shapes and sizes to produce decorative details such as cornices, quoins, keystones, arches, columns, reveals, shadow lines, special moldings, etc. Relatively easy to clean and repair small areas.

**DISADVANTAGES:** Proper detailing and choice of an experienced applicator is critical. Some manufacturers have significantly less experience than others and have more limited technical support staff. Some manufacturers have model code research reports, others do not. Many residential contractors do not have the skills and experience of commercial applicators. The specification control and inspection, typical with commercial work, is frequently absent on residential projects. Warranties vary considerably and should be studied and compared carefully. Insurance and code agencies may not allow barrier systems without certification by design professionals as to their proper detailing. Some states, such as North Carolina, and model codes (UBC) do not allow the use of barrier systems with wood-frame construction. The use of barrier systems should be carefully monitored on a case-by-case basis, as the codes are changing. Extreme heat, dryness, cold (especially freeze-thaw), and moisture conditions affect the system's performance. Proper flashing, high-performance sealants, and weather barriers are essential to good performance, but sealants should not be relied upon in the absence of other weather barriers. Requires careful selection of windows and flashing detailing to assure wall integrity is not compromised by water weeping into the wall cavity at sill and sill/jamb interface. Termites and carpenter ants can tunnel into foam plastic and use it as a habitat.

### 3. INSTALL AN EIFS MOISTURE DRAINAGE SYSTEM.

Moisture drainage systems, also called water-managed or rain-screen systems, have been used in commercial applications since the early 1990s, and are currently becoming the system of choice for housing among architects, designers, builders, and code officials. They are similar to barrier systems except that

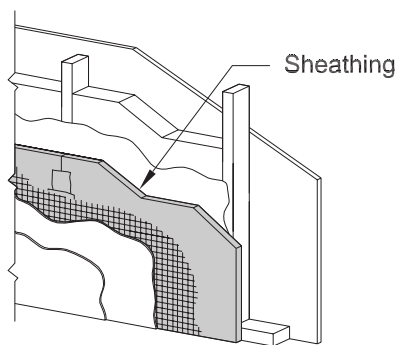

FIGURE 3

EIFS WITHOUT INSULATION

they employ a drainageway behind the insulation either in the form of vertical grooves cut in the insulation board, vertical furring strips, or a woven fabric drainage mat or other drainage system (Fig. 1). Proper flashings, weather barriers, and sealant details remain critical as water should still be kept out of the system. EIFS systems should stop well above grade to restrict insect access and allow for inspection.

**ADVANTAGES:** All the advantages of barrier EIFS with the additional protection of drainageways to evacuate

moisture from the system. Perceived by most builders, architects, and designers as an improved system. Recommended or required by increasing numbers of insurance companies and code agencies.

**DISADVANTAGES:** Generally require mechanical fastening of the foam insulation board, which is more labor intensive than adhesive applications. Require more attention and cost for secondary weather barriers and accessories. Require careful attention to system details, including housewrap overlaps to avoid the channeling of moisture behind these weather barriers, particularly at windows, doors, and other openings. Termites and carpenter ants can tunnel into foam plastic backing and use it as a habitat. There has been limited testing and performance data on the various drainage systems employed. Some building researchers and experts remain unconvinced that this system solves all the performance problems with barrier systems.

## FURTHER READING

*EIFS Design Handbook*, CMD Associates, 1800 Westlake Avenue North, Suite 203, Seattle, WA 98109; 206-285-6811; [www.eifs.com/aboutcmd.htm](http://www.eifs.com/aboutcmd.htm).

*EIFS New Construction Inspection Manual*, CMD Associates, 1800 Westlake Avenue North, Suite 203, Seattle, WA 98109; 206-285-6811; [www.eifs.com/aboutcmd.htm](http://www.eifs.com/aboutcmd.htm).

*EIFS Restoration Guide*, Dow Corning #62-510B096; 517-496-6000.

"EIFS Wall Weathers 75-mph Wet Spray Test with No Sealers," *Energy Design Update*, October 1998, pp. 10-12.

"Housewraps vs. Felt," Paul Fiset, *Journal of Light Construction*, November 1998.

*Installation Checklist*, Exterior Insulation Manufacturer's Association (EIMA), 3000 Corporate Center Drive, Suite 270, Morrow, GA 30260; 800-294-3462; [www.eifsfacts.com](http://www.eifsfacts.com).

"Installing Water-Managed Synthetic Stucco," Russ Minkovich, *Journal of Light Construction*, September 1998.

"Sill Sentry Designed to Treat Leaking Windows," *Energy Design Update*, June 1998, pp. 12-13.

"Synthetic Stucco," Steven Culpepper, *Fine Homebuilding*, October/November 1996.

## PRODUCT INFORMATION

EIFS Industry Members Association (EIMA), 3000 Corporate Center Drive, Suite 270, Morrow, GA 30260; 800-294-3462; [www.eifsfacts.com](http://www.eifsfacts.com).

Dow Corning Corporation, Midland, Michigan 48686-0994; 517-496-6000; [www.dowcorning.com](http://www.dowcorning.com).

Dryvit Energy Systems, Inc., One Energy Way, P.O. Box 1014, West Warwick, RI 02893; 800-556-7752; [www.dryvit.com](http://www.dryvit.com).

Finestone (Simplex Products Div.), 1149 Treat Street, Adrian, MI 49221-0010; 517-263-8881.

Omega Products Corp., P.O. Box 1889, Orange, CA 92668; 714-935-0900; [www.omega-products.com](http://www.omega-products.com).

Parex, Inc., P.O. Box 189, Redan, GA 30074; 800-537-2739; [www.parex.com](http://www.parex.com).

Pleko Systems International, Inc., P.O. Box 98360, Tacoma, WA 98498; 206-472-9637; [www.pleko.com](http://www.pleko.com).

Retro Tek, 4987 County Highway North, Sun Prairie, WI 53590; 800-225-9001.

Senergy Division of HSC, 10245 Centurion Parkway North, Jacksonville, FL 32256; 904-996-6000.

Stuc-o-Flex International, Inc., 17639 Northeast 67th Court, Redmond, WA 98052; 800-305-1045.

TEC Incorporated, 315 South Hicks Road, Palatine, IL 60067; 847-358-9500.

Universal Polymers, Inc., 319 North Main Street, Springfield, MO 65804; 800-752-5403.

US Gypsum Company, 125 South Franklin Street, Chicago, IL 60606; 800-USG-4YOU; www.usg.com.

W.R. Bonsal Co., 8201 Arrowridge Blvd., Charlotte, NC 28273; 800-334-0784; www.bonsal.com.

## 15.2 STUCCO

### ESSENTIAL KNOWLEDGE

Portland cement stucco is a traditional finish material that has been in use in North America for over 300 years. Currently installed as a three-coat system (scratch, brown, and color coat) it is sometimes abbreviated to a two-coat system, particularly over masonry.

### TECHNIQUES, MATERIALS, TOOLS

#### 1. PATCH EXISTING STUCCO.

Hairline cracks are very difficult to patch without making the repair more noticeable than the defect. Some installers recommend “dusting” with stucco. Cracks between  $\frac{1}{8}$  to  $\frac{1}{4}$  inch can be repaired by scraping out the topcoats to expose scratch coat. An acrylic bonding agent can be used to help bond the repair coats. On even larger cracks or holes, a self-adhesive fiberglass mesh can be used to strengthen the repair. Some large holes will require the repair of the building paper behind the wire mesh. For recoloring old stucco a “fog” coat of cement, color pigment, and lime, but no sand, is sometimes used. Acrylic additives increase ease of application and cover. Elastomeric coatings can also be used to seal and recolor old stucco.

ADVANTAGES: Stucco repair is relatively easy and cost-effective.

DISADVANTAGES: If large areas are affected, removal may be more practical.

#### 2. INSTALL A STUCCO EXTERIOR WALL FINISH.

Stucco is installed in the Northeastern and North Central states over gypsum sheathing using dimple or expanded metal diamond lath that holds the plaster away from the sheathing allowing for better cement bond, expansion and contraction with temperature changes, and for the creation of a drainageway. Over masonry substrates, stucco is typically applied directly to the substrate without lath. In hotter climates in the South and Southwest, stucco is often installed over paper-backed lath without sheathing material. This requires adequate bracing of the walls to prevent shear cracks. Stucco can be colored and scored to appear like brick, stone, and other materials.

ADVANTAGES: A proven material that stands up well to moisture in cold climates; can have integral color or can be coated with elastomeric coatings. Can have a variety of finishes. Easily repaired.

DISADVANTAGES: Requires experienced applicators. Requires fogging to prevent excessive fast curing and hairline cracking. Integral color can fade, especially if a dark color is chosen. Can be stained at grade by rain-splattered earth. Requires reinforcement at all openings and periodic expansion joints. Stucco is a poor insulator.

### FURTHER READING

*Oriental Stucco*, U.S. Gypsum Co., P682, April 1993.

*Portland Cement Plaster Stucco Manual*, Portland Cement Association, No. EB049, 1996.

“Patching Stucco,” Ron Webber, *Journal of Light Construction*, September 1997.

**ESSENTIAL KNOWLEDGE**

Trim has always been an important element in the appearance of houses, as well as a key weather and waterproofing component. As a finishing element around doors, windows, porches, roof edges, at corners, and at other building features, trim provides a decorative element and scale. There is a wide variety of material available for use as trim other than traditional solid wood, such as laminated wood lumber, engineered wood, wood/thermoplastic composites, fiber cement, and polymers. These new materials have the appearance of wood trim but promise longer service life. The major threats to trim are ultraviolet radiation, water damage, snow and ice, mold, rot, and insect infestation (all except ultraviolet (UV) related to moisture). Materials should be selected, detailed, and installed to limit the effects of exposure.

**TECHNIQUES, MATERIALS, TOOLS****1. REPAIR EXISTING WOOD TRIM WITH EPOXY FILLER.**

The decision whether to repair or replace the existing trim will depend on its condition, and whether the building is historically significant (if so, follow the U.S. National Park Services' *Guidelines for Rehabilitating Historic Buildings* referenced in Further Reading). Before repair or replacement, the conditions that caused damage to the trim should be corrected, if possible, and the decision to repair or replace can then be addressed. Most wood, even if it is seriously decayed, can be reconstituted by means of liquid epoxy consolidants that impregnate the wood fibers and harden into a mass that can be sawn, planed, drilled, nailed, sanded, glued, and painted. Most of these epoxy materials have weatherability as good as or better than wood, and work well at sills, thresholds, and other parts of the building that cannot be easily replaced. Epoxy putties are also available that work in conjunction with liquid epoxy to rebuild missing sections of decorative features and trim (Fig. 1).

**ADVANTAGES:** Restoration of damaged trim material may be less disruptive and less expensive than replacement. Helps maintain historical integrity of trim.

**DISADVANTAGES:** Requires careful application. May not be cost-effective for average rehabilitation project. May not be practicable if deterioration is extensive.



FIGURE 1

**USE OF EPOXY PUTTY TO REBUILD TRIM****2. INSTALL NEW TRIM.**

If a building's trim has deteriorated to the extent that it is unsightly or does not function as intended, and if epoxy consolidation is not cost-effective, the trim and any deteriorated substrate should be removed and replaced. If deterioration was caused by a lack of flashing (especially window or door heads), sealants or

poor detailing, those deficiencies should be corrected or the condition will be repeated. The choice of trim material has expanded considerably beyond that of solid wood. Trim options include:

■ **SOLID WOOD:**

For trim and fascias, solid wood is still the favorite material in many parts of the country due to its ease of application and general availability. Wood species include white and (to a lesser extent) southern yellow pine, imported pine species, and locally available fir including Douglas fir and Hem-fir. Heartwood grades of Western red cedar and redwood are more expensive, but considered more dimensionally stable and resistant to decay because of their natural extractives. Cedar often comes rough-sawn. Redwood is available in wide boards and is often used for fascias. Clear, vertical grain, all-heart wood material takes paint better, is more stable, and lasts longer than other grades. Finger-jointed trim is increasingly used and is available in larger sizes because it is comprised of glued sections of material. Back priming of all solid wood trim is recommended to protect it from moisture and to keep it from warping. Finished sides are best protected with two coats of paint or stain.

■ **LAMINATED VENEER LUMBER (LVL):**

At least one company, South Coast Lumber, makes LVL trim products. Its ClearLam™ product is made of Douglas fir core veneers and older face veneers glued together with phenolic adhesives and sprayed with a preservative to protect the trim in the field. The face is overlaid with a phenolic-based medium density overlay (MDO) sheet that eliminates face checking and serves as an excellent substrate for paint. All edges are fully coated with an elastomeric edge coating and primer. Easy to cut, nail, and install, ClearLam™ can be used for fascia, corner boards, and window and door trim, dimensionally stable without knots, checks, or cracks.

■ **ENGINEERED WOOD TRIM**

Engineered trim is a composite of wood fibers and resins. It resembles hardwood, but has added waxes, resins, and oils to give it better weather resistance. Engineered wood can be used for corner boards, fascias, rake boards, soffits, and door and window trim. A relatively inexpensive, uniform, consistent product, smoother and straighter than regular wood.

■ **WOOD/THERMOPLASTIC TRIM**

Wood/thermoplastic trim is a relatively new composite product made from thermoplastic resins and wood fiber. This material is exceptionally durable and is becoming popular for exterior decking applications and as window sills and door jambs. Several companies make limited sizes of flat stock for trim and extruded brickmold.

■ **FIBER-CEMENT TRIM**

Fiber-cement trim is available from manufacturers of fiber-cement siding products and is generally used in conjunction with those materials, although it need not be. Used as fascias, rake boards, corner boards, soffits, and window and door trim. Available in smooth and wood grain finishes, primed or unprimed. This material takes paint well and is available with a 50-year warranty against warping, cracking, and delamination.

■ **POLYMER TRIM**

Polymer trim, made from high density polyurethane, is cost effective in replicating the appearance of heavily decorative trim elements such as columns, railings, balusters, brackets, trellises, pediments, shutters, etc.

## **FURTHER READING**

“Alternatives to Solid Wood Exterior Trim,” Paul Fiset, Building Materials and Wood Technology Program, University of Massachusetts at Amherst, [www.umass.edu/bmatwt/index.html](http://www.umass.edu/bmatwt/index.html).

*The Secretary of the Interior's Standards for Rehabilitation and Guidelines for Rehabilitating Historic Buildings*, Washington: US Dept. of the Interior, National Park Service Preservation Assistance Division, 1990.

## PRODUCT INFORMATION

### RESTORATION PRODUCTS

Abatron, Inc., 5501 95th Avenue, Kenosha, WI 53144; 800-445-1754.

Conservation Services, 8 Lakeside Trail, Kinnelon, NJ 07045; 973-838-6412.

Gougeon Bros., Inc., P.O. Box 908, Bay City, MI 48707; 517-684-7286.

Preservation Resource Group, P.O. Box 1768, Rockville, MD 20849-1768; 301-309-2222; [www.prginc.com](http://www.prginc.com).

### LAMINATED VENEER LUMBER

South Coast Lumber Co., 815 Railroad Ave., P.O. Box 670, Brookings, OR 97415; 541-469-4177.

### ENGINEERED WOOD

SmartTrim™, Louisiana-Pacific Corp., 1 East First Street, Duluth, MN 55802; 800-648-6893; [www.lpcorp.com](http://www.lpcorp.com).

Prime Trim™, Georgia Pacific Corp., 133 Peachtree Street, NE, Atlanta, GA 30303; 404-652-4000.

Trim Craft™, Temple Inland Forest Products, P.O. Box N, Biboll, TX 75941; 800-231-6060; [www.temple.com/tpgl.html](http://www.temple.com/tpgl.html).

Protrim™, ABT Co., 10115 Kencei Avenue, Suite 150, Halesville, NC 28078; 800-927-3146; [www.altco.com/trim.htm](http://www.altco.com/trim.htm).

Forestrim™, Forestex, P.O. Box 68, Forest Grove, OR 97116; 503-357-2131.

American Hardboard Association, 520 North Hicks Rd., Palatine, IL 60067; 312-934-8800.

### WOOD/THERMOPLASTIC COMPOSITE

Durawood PE, The Eaglebrook Companies, 2600 West Roosevelt Rd., Chicago, IL 60608; 312-491-2500.

FrameSaver™, BMS, P.O. Box 631247, 1124 Bennet Clark Rd., Nacogdoches, TX 75963; 409-569-8211.

Crane Plastics Co., P.O. Box 1047, Columbus, OH 43216; 800-366-8472.

### FIBER CEMENT

Cem-Trim™, FLP Inc., Excelsior Industrial Park, P.O. Box 99, Blandon, PA 19510-0099; 888-327-0723; [www.flpinc.com](http://www.flpinc.com).

Harditrim™, James Hardie Building Products, 26300 Los Alameda, Suite 250, Mission Viejo, CA 92691; 888-J-HARDIE; [www.jameshardie.com](http://www.jameshardie.com).

Maxitrim™, Maxitile, Inc., 17141 South Kingview Avenue, Lason, CA 90746; 310-217-0316; [www.maxitile.com](http://www.maxitile.com).

Temple Inland Forest Products, P.O. Box N, Biboll, TX 75941; 800-231-6060; [www.temple.com](http://www.temple.com).

### POLYMER

Fypon, 22 West Pennsylvania Avenue, Stewartstown, PA 17363; 800-537-5349.

Outwater Plaster Industries, P.O. Box 347, Woodridge, NJ 07075; 800-835-4400; [www.outwater.com](http://www.outwater.com).

Style-Mark, Inc., 960 West Barre Road, Archibold, OH 43502; 800-446-3040; [www.style-mark.com](http://www.style-mark.com).



# SEALANTS & CAULKS

## ESSENTIAL KNOWLEDGE

Sealants and caulks are the first line of defense, serving as a barrier to both water and air infiltration. However, not all joints are meant to be caulked; some provide an exit for air or moisture trapped within the wall assembly. In low-rise residential structures sealants and (to a lesser extent) caulks are used as elements of a weather barrier system that includes the exterior finish material, drainage planes (building paper or housewrap), ice and weathershield membranes, and flashing. Sealants and caulks are typically used at expansion joints, joints between dissimilar materials, joints at window and door openings, at the juncture of siding and trim, and at flashing. Several factors should be considered in order to achieve satisfactory performance of both sealants and caulks.

■ **Material Selection:** Materials must have the proper physical characteristics for the specific application, including elasticity (the ability of a sealant to return to its original profile), elongation (the ability of a sealant to stretch, as expressed as a positive or negative percentage), adhesion (bonding between the sealant and adjacent materials), durability, paintability, and compatibility with substrate and adjacent materials.

■ **Weatherability:** Sealants vary with respect to weathering characteristics. Indications of weathering include hardening of the material, chalking or discoloration, alligatoring, wrinkling, bubbling, sagging, erosion, or softening of the sealant surface. Sealants and caulks showing these characteristics should be replaced.

■ **Joint Design:** Sealant manufacturers recommend that sealants should adhere to only two surfaces by use of polyethylene backer rods or bond breaker tape. Three-surface adhesion will lead to cohesive failure (tearing). Narrow (less than  $\frac{3}{8}$  inch) or excessively deep sealant joints, that exceed a depth to width ratio of 1 to 2, may not allow for the proper compression, elongation, or adhesion of sealants. Small joints prove to be the most difficult to seal because the smallest movement can represent a significant percentage of expansion. Interior applications typically do not require nearly the same degree of elongation because the temperature is maintained within a narrow range.

■ **Installation:** The leading cause of sealant failure is improper installation, elements of which include improper priming or cleaning of the substrate; installation over incompatible coatings, materials, or contaminants (including existing sealants and lubricants); installation during periods of excessive cold or heat, rain, or dampness. Such failures are prime reasons for replacement of sealants and caulks in rehab work.

The distinction between caulk and sealant, terms often used interchangeably, is essentially the ability to conform to movement. Caulk typically provides for less movement but is easier to work and is used for interior applications, while a sealant is used for exterior purposes. Caulking usually refers to latex sealing compounds that meet ASTM C 834 *Standard Specification for Latex Sealing Compounds* while sealants usually refer to ASTM C 920 *Standard Specifications for Elastomeric Joint Compounds*.



Manufacturers' instructions and technical assistance should be closely followed. The selection of caulk should be guided by knowledge of the materials that are to be adhered and the material properties that are most critical, such as elongation, durability or ease of installation.

Sealants are continuously evolving with new formulations for lower cost, ease of installation, adherence, flexibility, and durability. Newer formulations have allowed greater range of uses, but no one product is ideal in all these respects. It is estimated that there are over 300 sealant manufacturers. Some make their own sealants while others sell sealants manufactured by others under their "private label." Among the most common types are:

- Latex and oil-based sealants, generally referred to as caulks with low flexibility and relatively poor durability, are low cost and easy to work, suitable for interior applications not exposed to prolonged moisture.
- Acrylic latex, sometimes referred to as rubberized latex, is a more durable and elastic variation suitable for interior and exterior applications. Small amounts of silicone emulsions are frequently added to enhance performance somewhat.
- Butyl rubber is commonly employed in insulated window assemblies and between layers of metal flashings because of its good adhesion qualities, ability to resist water and temperature extremes, and because it remains tacky. It has only moderate flexibility and is difficult to install.
- Kraton, a primer-less, solvent-based, synthetic rubber that has become popular as a general purpose sealant that adheres to most common substrates. Because it is solvent-based, it may shrink slightly.
- Silicone, used extensively in curtain wall, exterior insulation and finish systems (EIFS), and glazing applications. It is the most elastic and durable sealant, but not generally paintable. It is difficult to remove, and not suitable for porous materials in some formulations. Minimal shrinkage.
- Polyurethanes have excellent movement and durability characteristics, but the flexibility degrades over time, particularly in direct sunlight, and they are difficult to apply and clean-up.

TABLE 1

**TYPES OF CAULKING MATERIALS**

| BASE TYPE         | RETAIL \$<br>(per 10 oz) | EST. LIFE<br>(years) | USES                                  | CLEAN UP                           |
|-------------------|--------------------------|----------------------|---------------------------------------|------------------------------------|
| Oil               | 1-2                      | 1-3                  | Most dry surfaces*                    | paint thinner                      |
| Polyvinyl acetate | 1.50-2                   | 1-3                  | Indoor surfaces only*                 | water                              |
| Styrene rubber    | 2-2.50                   | 3-10                 | Most dry surfaces*                    | paint thinner                      |
| Butyl             | 2.50-3                   | 4-10                 | Masonry and metal**                   | paint thinner                      |
| Acrylic latex     | 2-4                      | 5-20+                | Most dry surfaces*                    | water                              |
| Kraton            | 5-7.50                   | 10-15                | Most dry surfaces*                    | paint thinner                      |
| Polyurethane      | 4.50-10                  | 15-20+               | Masonry**                             | acetone, MEK                       |
| Silicone          | 4-7                      | 20+                  | Glass, Aluminum*<br>(not for masonry) | paint thinner,<br>naphtha, toluene |

\* wood, drywall, aluminum; e.g., gaps in wood frames around perimeter of house, plumbing penetrations, gaps in rough openings around windows and doors, boots around supply and return HVAC grills, seal between bottom plates and subfloor.

\*\* gaps in masonry construction.

All sealants require surface preparation and appropriate primers as directed by the manufacturer. Sealants are only able to provide for movement in two directions; if the sealant contacts a third surface it will detach from the surface with the least adhesion. Sealants typically are applied with half the width adhered to either side of the opening in an hour glass shape (Fig. 1). The width of the opening is exposed on one side and must be prevented from adhering to materials along its other side with a non-adhering surface referred to as a bond breaker or backer material. The bond breaker material also serves to shape and support the profile of the sealant and as a secondary barrier.

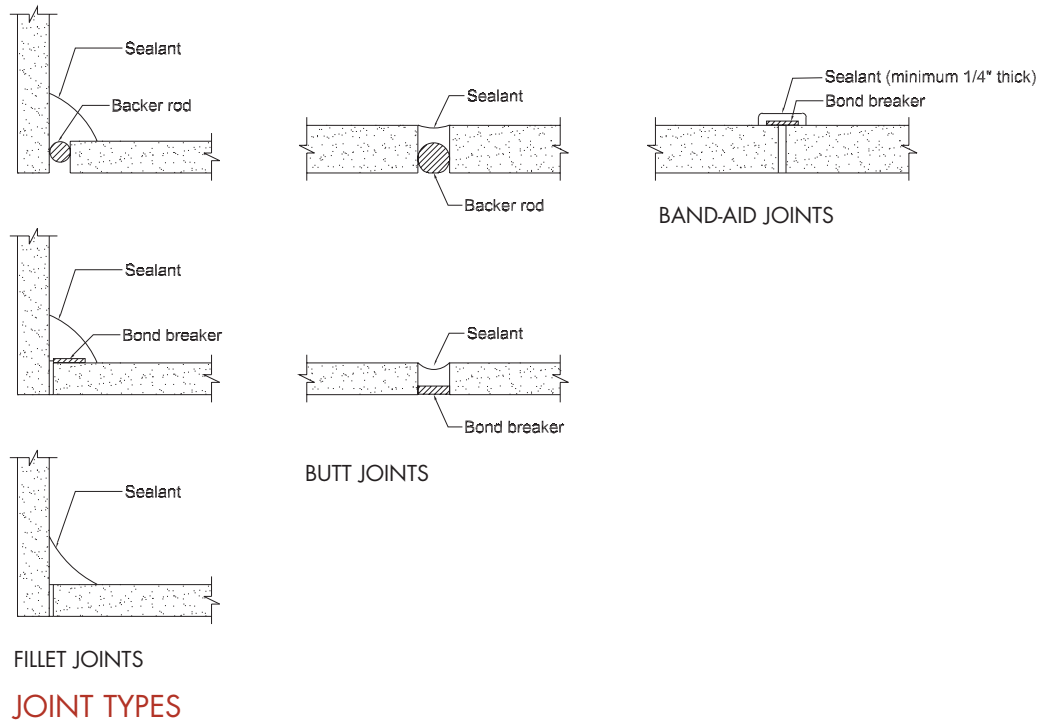

FIGURE 1

## TECHNIQUES, MATERIALS, TOOLS

### 1. PREPARE SURFACE, REMOVE EXISTING SEALANTS

All surfaces must be sound, clean, dry, and free of frost, dirt, oil release agents, loose particles, efflorescence, old sealants, and other foreign substances that impair adhesion bond. On impervious surfaces, such as glass, metals, or paints, sealant manufacturers may recommend a commercial grade solvent cleaner such as Xyol, toluene, or alcohol, or may produce one themselves. For porous surfaces such as cement board, concrete, concrete block, old brick, and stone, joints can be cleaned by cutting, scraping, sandblasting, saw cutting, or grinding. Remaining loose dust and particles should be removed by dusting with a stiff non-metallic brush, vacuuming, or blowing with oil-free compressed air. Some sealants require a primer prior to application, some do not. Follow manufacturers recommendations.

**ADVANTAGES:** Proper preparation will help ensure maximum life of sealant performance.

**DISADVANTAGES:** Removing contaminants and old sealants, especially silicones, is time consuming and expensive.

### 2. INSTALL SEALANT.

Proper installation of sealant is absolutely critical to performance. The methods of preparation and installation vary among manufacturers and it is best to consult their literature for instructions. Sealants are available in essentially four types: preformed, tube, cartridge, bulk. Typically, the easier the installation

method, the lower the anticipated performance. For this reason materials available in tubes tend to be water soluble caulk materials suitable for interior repairs. Materials designed for exterior purposes, specifically windows and doors, require higher performing materials and larger quantities. These materials generally require some form of mechanical means of applying the sealant. The traditional hand-operated gun provides a relatively simple device with convenient cartridges. Larger bulk-loading guns are also available to provide for economy in the packaging of materials or when two-part sealants are to be combined on site. Applications of large amounts of sealant are ideally suited for power-assisted equipment. Traditionally this was pneumatically driven, requiring an air compressor. New equipment developed specifically for this purpose is either electrically or battery driven. With the requirements of application being so specific, these power tools and preformed materials provide for consistency of application.

**ADVANTAGES:** New automated tools and new materials provide for greater ease of installation and performance than ever before. The wide variety of materials is suitable for virtually any condition.

**DISADVANTAGES:** The improper selection of sealants has the potential of damaging or discoloring adjacent materials.

## **FURTHER READING**

“Caulking,” Al Brendenberg, *Today's Homeowner*, [www.todayshomeowner.com/todayarticles/paint/04.97.62.html](http://www.todayshomeowner.com/todayarticles/paint/04.97.62.html).

“Caulking About the Weather,” Josh Garskof, *Old-House Journal*, November/December 1996.

“Caulks and Sealants,” *Fine Homebuilding*, Bruce Greenlaw, June/July 1990.

“Premature Sealant Failure,” *The Construction Specifier*, David H. Nicastro and Joseph P. Solinski, April 1997.

“Silicone Caulking Basics,” Brian Zavitz, *Fine Homebuilding*, August/September 1997.

## **PRODUCT INFORMATION**

AC Products, 172 East La Jolla Street, Placentia, CA 94870; 800-238-4204.

AEG, 3 Shaw's Cove, P.O. Box 6003, New London, CT 06320-1777.

ChemRex/PL Adhesives & Sealants, 889 Valley Park Drive, Shakopee, MN, 55379; 800-433-9517.

DAP, 2400 Boston Street, Suite 200, Baltimore, MD 21224; 800-543-3840; [www.dap.com](http://www.dap.com).

Dow Corning Corporation, Midland, MI 48606-0994; 517-496-6000; [www.dowcorning.com](http://www.dowcorning.com).

Franklin International, Construction Adhesives and Sealants, 2020 Brooks St., Columbus, OH 43207; 800-877-4583; [www.franklini.com](http://www.franklini.com).

GE Silicones, 260 Hudson River Road, Waterford, NY 12188; 800-255-8886; [www.ge.com](http://www.ge.com).

Insta-Foam Products, Inc., 1500 Cedarwood Drive, Joliet, IL 60435; 800-800-3626.

Macco Adhesives, 925 Euclid Avenue, Cleveland, OH 44115; 800-634-0015; [www.liquidnails.com](http://www.liquidnails.com).

Macklanburg-Duncan, 4041 North Santa Fe, Oklahoma City, OK 73118; 800-654-8454; [www.macdunc.com](http://www.macdunc.com).

Miracle Adhesives, TAC Intl, Air Station Industrial Park, Rockland, MA 02370; 800-503-6991.

NPC Sealants, 1208 South Eighth Avenue, P.O. 645, Maywood, IL 60153; 800-654-1042.

OSI Sealants, 7405 Production Drive, Mentor, OH, 44060; 800-321-3578; [www.osisealants.com](http://www.osisealants.com).

Polytite, 324 Ridge Avenue, Cambridge, MA 02140; 800-776-0930; [www.polytite.com](http://www.polytite.com).

Red Devil, 2400 Vaux Hall Road, Union, NJ 07083; 800-4-A-DEVIL; [www.reddevil.com](http://www.reddevil.com).

Resource Conservation Technology, 2633 North Calvert Street, Baltimore, MD 21218; 410-366-1146. 83

# PAINT & OTHER FINISHES

## ESSENTIAL KNOWLEDGE

Paints, stains, and other coatings protect wood from the deteriorating effects of moisture and ultraviolet radiation. Areas exposed to the greatest amount of sun and wind-driven rain deteriorate the fastest—typically the south and west exposures, and the higher portions of the building.

The performance of paints and stains on wood and wood-based composite products (plywood, oriented strand board, laminated beams, etc.) is affected by the wide range of properties between and within wood species. Understanding the physical characteristics of various wood species contributes to appropriate paint and stain selection. Varying properties affecting the performance of finishes include:

- **Density:** High density woods (southern pine, Douglas fir, oak) tend to swell, cup, and check more than low density, “light” woods (redwood, cypress, western red cedar) causing stresses in film coatings that can lead to cracking and flaking.
- **Grain characteristics:** Vertical grain woods (western red cedar, redwood) have excellent paint-holding characteristics because of their narrow bands. Flat grained woods (southern pine, Douglas fir) have dense, wide bands and hold paint less well, especially if smooth finished.
- **Texture:** Some hardwoods (oak, ash) have large pores that cause pin holes to form in the finish. Other hardwoods (yellow poplar, magnolia, and cottonwood) have smaller pores and good paintability. Paint and penetrating stains will last longer on rough-sawn lumber and plywood than on smooth surfaces because, in order to achieve the proper coverage, the paint buildup is necessarily greater. Smooth surfaces of some species, including western red cedar, may exhibit a condition known as “mill glaze” created during the planing or drying process. This condition can inhibit the adherence of solid body stains.
- **Knots, extractives, and other irregularities:** Knots absorb finish differently than the surrounding wood. Pitch (resin), oils, and other extractives can leach out of wood and cause staining. Better grades of wood have fewer defects and are preferable for painting.
- **Growth ring orientation:** Flat-grained, softwood lumber (typically used in most grades) shrinks and swells to a greater extent than vertical-grained lumber. Edge-grained softwoods (available at a premium price) cup less and hold paint better than flat-grained wood of the same species (Fig. 1).

Most residential paints and stains are classified as oil or alkyd-based or latex-based (which includes acrylic). Oil or alkyd-based paints contain inorganic pigments suspended in a natural oil such as linseed, or synthetic resin (alkyd), and usually a solvent such as mineral spirits (paint thinner), toluene, or xylol (all petroleum distillates). These paints cure by reacting with oxygen to form a polymeric film. Latex paints contain inorganic pigments, petroleum-based solvents, and various latex resins, but the solvent is mostly water. The curing of both paints releases volatile organic compounds (VOCs) but the amount is much less in latex paints (7 to 9 percent, compared to as much as 50 percent for alkyds). New paints on the market release very low or no VOCs.

Modern exterior latex paints, especially the all-acrylic, are generally considered to perform better than oil or alkyd-based coatings. Even though alkyd paints provide a more permeable barrier to moisture, acrylic paints are faster drying, more elastic, hold color better, tend not to crack as much, and are easier to work with and clean up. In general, latex paints and solid-color stains can be applied over either oil or latex-based finishes. Oil-based coatings should only be applied over oil-based finishes and not latex products. Better quality paints contain a greater amount of pigment by weight, cover better, last longer, and are more cost-effective than lower-quality paints.

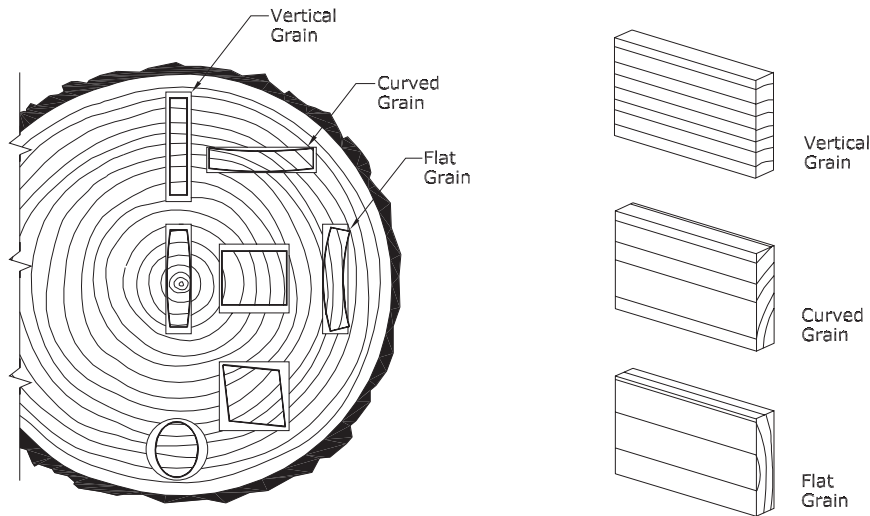

FIGURE 1

## GROWTH RING/GRAIN ORIENTATION

### TECHNIQUES, MATERIALS, TOOLS

#### 1. MAINTAIN EXISTING COATED SURFACES.

Painted, stained, or treated surfaces must be protected from UV radiation, rain, dirt, and mold and mildew to perform properly. Roof overhangs can help, however, soffits and sidewalls under wide overhangs will still collect dirt and water-soluble salts (which can interfere with the adhesion of new paints). Dirt, salts, and chalk (individual pigment particle from weathered paint) can be removed by scrubbing with non-metallic bristle brushes and water. For stubborn stains, a non-ammoniated detergent can be added. Mold and mildew can be removed by scrubbing with a mixture of one or two parts of bleach to a gallon of water. Surfaces should be rinsed thoroughly with clean water prior to refinishing. All landscaping should be protected.

ADVANTAGES: Cost-effective, will increase service life of coatings.

DISADVANTAGES: Surfaces will eventually need refinishing.

#### 2. PREPARE PREVIOUSLY COATED SURFACES.

Film-forming paints and solid color stains can fail by cracking, flaking or peeling. Such failures are typically caused by moisture penetration, painting over weathered wood, prolonged weathering, too much time between application of primer and top coat applications, and chalked, mildewed, or dirty surfaces that were insufficiently cleaned prior to coating. Blistering, another common failure mode, can be caused by high temperature or moisture. Temperature blisters are caused by rapid increases in temperature soon after painting or by poor quality paint. Moisture blisters can occur anytime excessive moisture penetrates the surface edges, or back side of the painted material. The source of the moisture should be eliminated prior to refinishing. Deteriorated coatings can be removed by scrubbing, scraping, sanding, heat, chemical

strippers, or pressure washing. Scrubbing is discussed in paragraph 1 above; scraping is best done with long handled professional scrapers; sanding is best done with orbital or siding sanders equipped with tungsten carbide abrasive disks (less likely to clog than conventional sandpaper); electrically heated paint removers can be used to soften and strip oil- or alkyd-based paints; chemical strippers such as lye and trisodium phosphate (TSP) contain caustic solutions and should be used with care. Naturalizing and sanding is essential. Refer to chemical manufacturers's recommendations and directions. Wet sand blasting and high-pressure water sprays are also used, but sand blasting can easily erode and destroy materials. Pressure washing can be effective for large areas, but should also be used carefully as it can also damage material. Dry sandblasting should never be used as it is too destructive. Paint can be removed with an open-flame blowtorch, but this should be left to professionals as the danger from fire is constant and lead paint can give off noxious fumes. National (Occupational Safety and Health Administration (OSHA) and HUD), state, and local health departments should be contacted for recommendations and requirements affecting the removal of lead paint (for houses built or painted prior to 1978).

ADVANTAGES: Proper preparation will make painting easier and enhance the coating performance.

DISADVANTAGES: Time-consuming and expensive.

### 3. APPLY PAINT TO NEW OR EXISTING WOOD OR WOOD-BASED COMPOSITE MATERIALS.

To achieve maximum paint life on new wood, the U.S. Forest Products Laboratory recommends that new wood be initially treated with a paintable water repellent preservative (especially at openings such as windows and doors where water can collect on horizontal surfaces such as sills, and at lap, butt, and end joints of siding where the edge grain is exposed). On existing painted surfaces, sanding is particularly important in order to feather the edges of the existing paint to allow for uniform coverage where new and old coatings abut. If the existing paint is not feathered, the new paint will fail first (Fig. 2). High-quality stain-blocking acrylic latex primers are recommended. Alkyd or oil-based primers are recommended for woods with water-soluble extractives such as redwood and western red cedar, and are still preferred by many professional painters for new wood. Raw wood should be primed within a few weeks of installation as a longer delay can cause loss of adhesion. Two coats of good-quality all-acrylic house paint over the primer are recommended, especially on south and west exposures. A one-coat acrylic house paint over a properly applied primer should last four to five years; two coats can last twice as long. As with all remedial work, the various product manufacturers' recommendations for paint selection, surface preparation, and paint application should be followed. Most paint failures occur when recommendations are not followed.

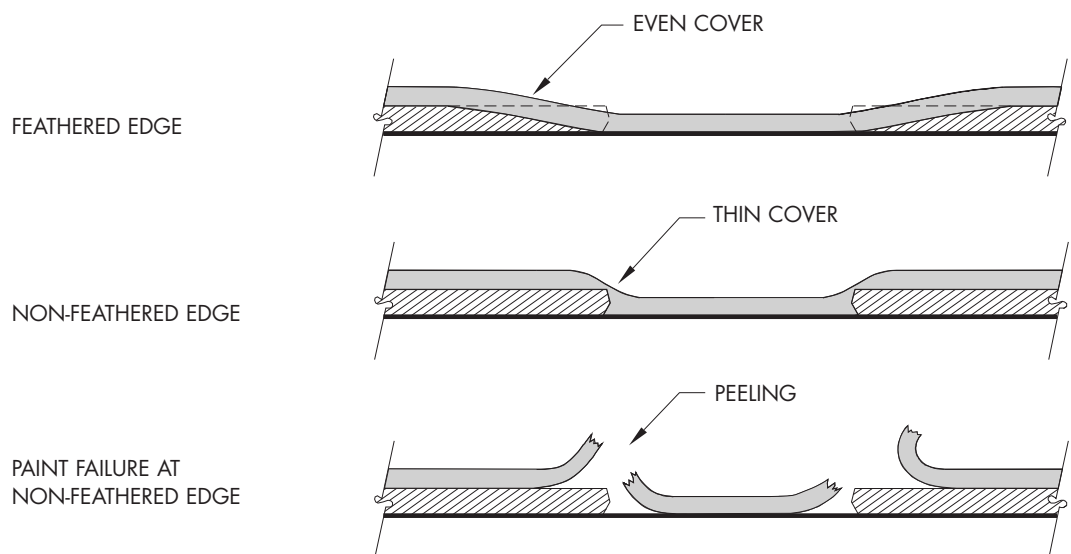



**ADVANTAGES:** Paint protects materials from weathering and deterioration due to the effect of rain and sun, and can dramatically alter the appearance of a house. Has the highest percentage of solids of conventional wood finishes, and can conceal surface defects and discolorations. New formulations of VOC-free paints are odorless, fast drying, and can be applied at lower temperatures than conventional latex paints, and adhere well, including over alkyd paints.

**DISADVANTAGES:** Paint is not a preservative and will not protect a substrate from decay if moisture penetrates the surface or is absorbed from behind. Will fail if applied incorrectly or without proper preparations. Not recommended for horizontal exposed surfaces such as wood decking, as water can get behind paint film and lead to decay. Requires periodic maintenance and repainting. Some new formulations dry so quickly that it is sometimes difficult to keep a wet paint edge. Alkyd paints are not recommended for use directly on masonry or other alkaline surfaces except over an alkali-resisting primer or sealer, not; or over a un-primed galvanized metal surface. Too frequent refinishing, especially with oil-based paints and solid-color stains, can lead to a thick coating buildup and subsequent cracking and peeling.

#### **4. APPLY OIL-BASED PENETRATING STAINS TO NEW OR EXISTING WOOD OR WOOD-BASED MATERIAL.**

Oil-based penetrating stains use linseed oil or alkyd formulas to seal and protect the wood substrate. Stains typically contain fungicides, water repellants, UV blockers, and other additives. These stains are available in varying degrees of pigment densities, from virtually clear and semi-transparent formulations designed to reveal and enhance the grain, to increasingly opaque coatings including semisolid and solid stains that hide the grain, but allow the substrate texture to be expressed. The greater the amount of pigment, the greater the hiding power and UV protection. Solid color stains are usually applied over primers, transparent stains are not.

**ADVANTAGES:** Time proven, popular coatings that protect and enhance the appearance of substrates. Resists blistering, cracking, and peeling better than paints (especially the more transparent formulations). Can be applied over a wide variety of new solid sidings, including shingles, shakes, plywoods, and trim. Can be used over some previously stained wood of an equal or less dense pigment formulation.

**DISADVANTAGES:** Not recommended for use over oriented strand board (OSB), cementitious or hardboard products (especially those with medium density overlay surfaces). May not penetrate and may cause unwanted gloss and blotchiness when used over existing unweathered penetrating stains. Not recommended for decking unless specially formulated for that use. Transparent and semi-transparent finishes require more frequent reapplication than more solid stains, especially for smooth-faced woods.

#### **5. APPLY SOLID COLOR ACRYLIC STAINS TO NEW OR EXISTING WOOD OR WOOD-BASED MATERIAL.**

The paint industry's interest in developing water-based low-VOC emitting stains has led a number of manufacturers to develop newly formulated, all-acrylic stains for siding products. These flat stains are not penetrating stains, but form protective films. They are thinner coatings than acrylic paints and are designed to resist cracking, blistering, and peeling while retaining the texture of the substrate materials. Used with primers, these stains are more flexible and have better color retention than oil-based stains. They can be used over previously treated oil-based penetrating stains, trim, and a variety of other materials, including primed metal, cured masonry, plywood, medium density overlaid plywood and hardboard, cementitious siding, and stucco.

**ADVANTAGES:** Protects and provides strong color accents to substrate materials. Less likely to peel than paints.

**DISADVANTAGES:** Not as long-lasting or easily cleaned as all-acrylic paints.

#### **6. APPLY SPECIALTY COATINGS.**

Many specialty coatings are available that compliment paint and stain products, including:

- Paints designed specifically for masonry.
- Tinted and untinted bleaching oils that contain oxides to accelerate the weathering process.
- Slightly tinted, clear, oil-based finishes that retard the normal gray weathering of wood and impart a slight reddish-brown tint.



■ Wood cleaners that are formulated to remove mildew, mold, algae, and dirt using chemicals such as sodium hydroxide.

■ Wood “brighteners” that are formulated to remove tannin bleed in extractive-prone woods, such as cedar and redwood.

ADVANTAGES: Unique and potentially useful products for special needs.

DISADVANTAGES: Difficult to anticipate the results of these products without careful research and inspection of their use on existing buildings, or examination of samples.

## FURTHER READING

“Finishes for Exterior Wood—Selection, Application, and Maintenance,” U.S. Department of Agriculture, Forest Service, Forest Products Laboratory, Forest Products Society, Madison, WI, 608–231–2152.

“Latex Enamel Problems and Solutions,” James Berney, Dan Greenough, and Doug Kelly, *Journal of Light Construction*, January 1997.

“The Art of Painting,” Brad Lemley, *This Old House*, June 1998.

# APPENDIX

## PROFESSIONAL ASSOCIATIONS & RESEARCH CENTERS

ADHESIVE AND SEALANT COUNCIL  
1627 K Street, NW, Suite 1000  
Washington, DC 20006-1707  
202-452-1500  
[www.ascouncil.org](http://www.ascouncil.org)

AMERICAN FIBERBOARD ASSOCIATION  
AMERICAN HARDBOARD ASSOCIATION  
1210 West Northwest Highway  
Palatine, IL 60067  
847-934-8800

AMERICAN FOREST & PAPER ASSOCIATION  
111 19th Street, NW, Suite 800  
Washington, DC 20036  
202-463-2700  
[www.afandpa.org](http://www.afandpa.org)

AMERICAN INSTITUTE OF TIMBER  
CONSTRUCTION  
7012 South Revere Parkway  
Suite 140  
Englewood, CO 80112  
303-792-9559  
[www.aitc-glulam.org](http://www.aitc-glulam.org)

AMERICAN NATIONAL STANDARDS INSTITUTE  
11 West 42nd Street, 13th Floor  
New York, NY 10036  
212-642-4900  
[www.ansi.org](http://www.ansi.org)

AMERICAN SOCIETY FOR TESTING AND  
MATERIALS  
100 Barr Harbor Drive  
West Conshohocken, PA 19428  
610-832-9500  
[www.astm.org](http://www.astm.org)

AMERICAN SOCIETY OF CIVIL ENGINEERS  
1801 Alexander Bell Drive  
Reston, VA 20191-4400  
800-548-2723  
[www.asce.org](http://www.asce.org)

AMERICAN WOOD COUNCIL  
P.O. Box 5364  
Madison, WI 53705-5364  
800-890-7732  
[www.awc.org](http://www.awc.org)

AMERICAN WOOD PRESERVERS ASSOCIATION  
P.O. Box 286  
Woodstock, MD 21163-0286

AMERICAN WOOD PRESERVERS INSTITUTE  
1945 Old Gallows Road, Suite 150  
Vienna, VA 22182  
703-893-4005

APA-THE ENGINEERED WOOD ASSOCIATION  
P.O. Box 11700  
Tacoma, WA 98411-0700  
253-565-6600  
[www.apawood.org](http://www.apawood.org)

ASSOCIATION OF THE WALL AND CEILING  
INDUSTRIES  
1600 Cameron Street  
Alexandria, VA 22314  
703-684-2924

BRICK INDUSTRIES ASSOCIATION  
11490 Commerce Park Drive  
Reston, VA 20191-1525  
703-620-0010  
[www.bia.org](http://www.bia.org)

BUILDING SEISMIC SAFETY COUNCIL  
NATIONAL INSTITUTE OF BUILDING SCIENCES  
1090 Vermont Avenue NW, Suite 700  
Washington, DC 20055  
202-289-7800  
[www@nibs.org](http://www@nibs.org)

BUILDING STONE INSTITUTE  
P.O. Box 5047  
White Plains, NY 10602-5047  
914-232-5725

CALIFORNIA REDWOOD ASSOCIATION  
405 Enfrente Drive, Suite 200  
Novato, CA 94949  
888-225-7339  
[www.calredwood.org](http://www.calredwood.org)

CANADA MORTGAGE AND HOUSING  
CORPORATION  
Housing Information Center  
700 Montreal Road  
Ottawa, ON, Canada K1A 0P7  
613-748-2367  
[www.cmhc-schl.gc.ca](http://www.cmhc-schl.gc.ca)

CANADIAN CONSTRUCTION MATERIALS  
CENTRE  
Institute for Research in Construction  
National Research Council  
Montreal Road, Bldg. M-24  
Ottawa, ON, Canada K1A 0R6  
613-993-6189  
[www.nrc.ca/ccmc](http://www.nrc.ca/ccmc)

CEDAR SHAKE AND SHINGLE BUREAU  
P.O. Box 1178  
Sumas, WA 98295  
604-462-8961  
[www.cedarbureau.org](http://www.cedarbureau.org)

CELLULOSE INSULATION MANUFACTURERS  
ASSOCIATION  
136 South Keowee Street  
Dayton, OH 45402  
937-222-2462  
[www.cellulose.org](http://www.cellulose.org)

CONSTRUCTION SPECIFICATIONS INSTITUTE  
601 Madison Street  
Alexandria, VA 22314  
703-684-0300  
[www.csinet.org](http://www.csinet.org)

COPPER DEVELOPMENT ASSOCIATION  
260 Madison Avenue  
New York, NY 10016  
800-232-3282  
[www.copper.org](http://www.copper.org)

COUNCIL OF AMERICAN BUILDING OFFICIALS  
5203 Leesburg Pike, Suite 708  
Falls Church, VA 22041  
703-931-4533  
[www.cabo.org](http://www.cabo.org)

THE ENGINEERED WOOD ASSOCIATION  
7011 South 19th Street  
P.O. Box 11700  
Tacoma, WA 98411  
253-565-6600  
[www.apawood.org](http://www.apawood.org)

EXPANDED POLYSTYRENE (EPMA)  
MOLDERS ASSOCIATION  
1926 Waukegan Road, Suite 1  
Glenview, IL 60025-1770  
800-607-3772

FOREST PRODUCTS LABORATORY  
US DEPARTMENT OF AGRICULTURE  
One Gifford Pinchot Drive  
Madison, WI 53705-2398  
608-231-9200  
[www.fpl.fs.fed.us/](http://www.fpl.fs.fed.us/)

GYPSUM ASSOCIATION  
810 1st Street, NE, Suite 510  
Washington, DC 20002  
202-289-5440  
[www.gypsum.org](http://www.gypsum.org)

HARDWOOD PLYWOOD & VENEER  
ASSOCIATION  
P.O. Box 2789  
Reston, VA 20195-0789  
703-435-2900  
[www.hpva.org](http://www.hpva.org)

INTERNATIONAL ASSOCIATION OF STONE  
RESTORATION AND CONSERVATION  
30 Eden Alley, Suite 301  
Columbus, OH 43215  
614-461-5852

INTERNATIONAL CONFERENCE OF BUILDING  
OFFICIALS  
5360 South Workman Mill Road  
Whittier, CA 90601  
800-336-1963  
[www.icbo.org](http://www.icbo.org)

INTERNATIONAL FIRESTOP COUNCIL  
25 North Broadway  
Tarrytown, NY 10591  
914-332-0040  
[www.firestop.org](http://www.firestop.org)

INTERNATIONAL INSTITUTE FOR LATH AND  
PLASTER  
820 Transfer Road  
St. Paul, MN 55114-1406  
612-645-0208

INTERNATIONAL REMODELING  
CONTRACTORS ASSOCIATION  
17 South Main Street  
East Granby, CT 06026  
800-937-4722  
[www.remodelingassociation.com](http://www.remodelingassociation.com)

INTERNATIONAL STAPLE AND TOOL  
ASSOCIATION (ISANTA)  
435 North Michigan Avenue  
Chicago, IL 60611  
312-644-0828

MASON CONTRACTORS ASSOCIATION OF  
AMERICA  
1910 South Highland Ave., Suite 101  
Lombard, IL 60148  
630-705-4200  
[www.masoncontractors.com](http://www.masoncontractors.com)

THE MASONRY SOCIETY  
2619 Spruce Street, Suite B  
Boulder, CO 80302-3808  
303-939-9700

NAHB REMODELERS COUNCIL  
1201 15th Street, NW  
Washington, DC 20005  
202-822-0212

NATIONAL ASSOCIATION OF THE  
REMODELING INDUSTRY  
3800 North Fairfax Drive, Suite 2  
Arlington, VA 22203-1627  
703-276-7600  
[www.ebtech.com](http://www.ebtech.com)

NATIONAL CONCRETE MASONRY ASSOCIATION  
2302 Horsepen Road  
Herndon, VA 20171-3499  
703-713-1900  
[www.ncma.org](http://www.ncma.org)

NATIONAL FRAME BUILDERS ASSOCIATION  
4840 West 15th Street, Suite 1000  
Lawrence, KS 66049-3876  
800-844-3781  
[www.knight.idir.net](http://www.knight.idir.net)

NATIONAL INSTITUTE OF BUILDING SCIENCES  
1090 Vermont Avenue, NW, Suite 700  
Washington, DC 20005  
202-289-7800  
[www.nibs.org](http://www.nibs.org)

NATIONAL PAINT AND COATINGS  
ASSOCIATION  
1500 Rhode Island Avenue, NW  
Washington, DC 20005  
202-462-6272  
[www.paint.org](http://www.paint.org)

NATIONAL PARTICLEBOARD ASSOCIATION  
18928 Premiere Court  
Gaithersburg, MD 20879-1569  
301-670-0604  
www.pbmdf.com

NATIONAL TECHNICAL INFORMATION SERVICE  
US DEPARTMENT OF COMMERCE  
5285 Port Royal Road  
Springfield, VA 22161  
800-553-6847  
www.ntis.gov

NORTH AMERICAN INSULATION  
MANUFACTURERS ASSOCIATION  
44 Canal Center Plaza, Suite 310  
Alexandria, VA 22314  
703-684-0084  
www.naima.org

PAINTING AND DECORATING CONTRACTORS  
OF AMERICA  
3913 Old Lee Highway., Suite 33B  
Fairfax, VA 22030  
800-332-7322  
www.pdca.com

POLYISOCYANURATE INSULATION  
MANUFACTURER ASSOCIATION  
1001 Pennsylvania Avenue, NW, Fifth Floor  
Washington, DC 20004  
202-624-2709  
www.pima.org

PORTLAND CEMENT ASSOCIATION  
5420 Orchard Road  
Skokie, IL 60087-1083  
847-966-6200  
www.portcement.org

SEALANT, WATERPROOFING, AND  
RESTORATION INSTITUTE  
2841 Main  
Kansas City, MO 64108  
816-472-7974  
www.swrionline.org

SOUTHERN FOREST PRODUCTS ASSOCIATION  
P.O. Box 641700  
Kenner, LA 70064-1700  
504-443-4464  
www.sfpa.org

STRUCTURAL BOARD ASSOCIATION  
3413 56th Street, Suite A  
Gig Harbor, WA 98335  
253-858-7472  
www.sips.org

STRUCTURAL INSULATED PANEL ASSOCIATION  
1331 H Street, NW, Suite 1000  
Washington, DC 20005  
202-347-7800  
www.sips.org

STUCCO MANUFACTURERS ASSOCIATION  
507 Evergreen Road  
Pacific Grove, CA 93950  
408-649-3466

TIMBER FRAME BUSINESS COUNCIL  
c/o Jerry Rouleau  
P.O. Box B1161  
Hanover, NH 03755

TRUSS PLATE INSTITUTE  
583 D'Onofio Drive, Suite 200  
Madison, WI 53719  
608-833-5900

VINYL SIDING INSTITUTE  
1801 K Street, Suite 600K  
Washington, DC 20006  
888-FORVSI-1  
www.vinylsiding.org

WESTERN RED CEDAR LUMBER ASSOCIATION  
1200–555 Burrard Street  
Vancouver, BC, Canada V7X 1S7  
604–684–0266  
[www.coti.org/WRCLA](http://www.coti.org/WRCLA)

WESTERN WOOD PRODUCTS ASSOCIATION  
522 SW Fifth Avenue, Suite 500  
Portland, OR 97204–2122  
503–224–3930  
[www.wwpa.org](http://www.wwpa.org)

WOOD TRUSS COUNCIL OF AMERICA  
6425 Normandie Lane  
Madison, WI 53719  
608–274–4849  
[www.trusspro.com/wtea/](http://www.trusspro.com/wtea/)

## THE REHAB GUIDE

**VOLUME ONE:** FOUNDATIONS

**VOLUME TWO:** EXTERIOR WALLS

**VOLUME THREE:** ROOFS

**VOLUME FOUR:** WINDOWS AND DOORS

**VOLUME FIVE:** PARTITIONS, CEILINGS, FLOORS, AND STAIRS

**VOLUME SIX:** KITCHENS & BATHS

**VOLUME SEVEN:** ELECTRICAL/ELECTRONICS

**VOLUME EIGHT:** HVAC/PLUMBING

**VOLUME NINE:** SITE WORK

U.S. Department of Housing and Urban Development  
Washington, DC 20410-6000

Official Business  
Penalty for Private Use, \$300

August 1999  
HUD-DU100C000005956

